



Product catalogue 2022/2023

Update 01-2024

EMPUR® – Quality for your home



Quality „Made in Germany“ from one source

EMPUR® Produktions GmbH is a producer and full-range retailer of innovative, high-quality surface heating and cooling systems and has the right solution for every challenge:

- Surface heating/cooling systems for floor, walls and ceilings
- Systems without additional installation height or with minimum installation height for modernisation
- Diverse systems with composite panels and additional insulation for new buildings in the private, municipal or industrial sectors
- System accessories and tools
- High-quality heat distribution and drinking water systems
- Innovative control technology

The company produces and is solely responsible for over 90% of all system components itself using its state-of-the-art systems. We work under a structured quality management system, which is certified by DEKRA in accordance with the DIN EN ISO 9001 international norm.

In the interest of the most objective and neutral product evaluation possible, EMPUR® subjects its products to material testing and certification by nationally recognised testing institutes and assessment centres. High quality, continual and pioneering product developments, technical advice and support, a three-level distribution network across Germany, reliable services, as well as specialist training for wholesalers, tradesmen and planners make EMPUR® a competent partner in the heating industry.

Express delivery

Orders received by 11 a.m. are usually shipped on the same day. We charge a shipping and packaging fee of €9.80 per parcel for the dispatch of parcel service goods. Express despatch is possible on request. This excludes insulation products, manifold cabinets, chemical and bulky items. Carriage-paid delivery by lorry/forwarding agent according to delivery mode and/or consultation.

Validity

This documentation is valid upon issue dated October 1st, 2022 until reprinted. EMPUR® Produktions GmbH reserves the right to make changes according to technical advances and/or due to market requirements and to deliver without separate announcement.



The technical information in this price list represents the state of our knowledge and experience on going to press. Unless expressly agreed, however, they represent no assurance in the legal sense. The level of experience is constantly developing further. The latest edition of these price list brochures should always be used. The product applications described may not take into account special conditions in an individual case. Here suitability for the specific application purpose must be checked. Our products are delivered exclusively on the basis of our general conditions of sale and delivery. We reserve the right to make technical changes, price changes, errors and misprints.



1	 Contact persons + Legend	4 – 5		
2	 Heating pipes	6		
2.1	KLIMAPEX® plastic heating pipes PE-Xa as 5-layer pipe	6		
2.2	KLIMAPEX® plastic heating pipes PE-Xa as 3-layer pipe/PE-RT as 5-layer pipe	7		
2.3	KLIMAPEX® plastic heating pipes PE-RT as 5-layer pipe 6 bar	8		
2.4	KLIMAPEX® plastic heating pipes PE-RT as 3-layer pipe and metal composite pipe PE-RT/AL/PE-RT	8		
2.5	KLIMAPEX® plastic heating pipes, technical data	9		
3	 Underfloor heating systems in new builds	10		
3.1	PUR-THERM® stapler system	10 – 11		
3.2	Exclusiv-Klett system	12 – 13		
3.3	top-Nopp® nub system	14 – 15		
3.4	OPTIMAL II dry construction system	16 – 17		
3.5	Additional insulation (for all systems)	18		
4	 Underfloor heating systems for modernisation projects	20		
4.1	CUT-THERM® milling system	20 – 21		
4.2	top-Nopp® mini nub system	22 – 23		
4.3	Multibox-RTL individual room control	24		
5	 Wall heating systems	25		
5.1	Wall heating dry construction system	25		
5.2	Vertical wall heating as a wet system	26 – 27		
6	 Ceiling heating/cooling for new building/modernisation	28		
6.1	Ceiling/wall elements and accessories	28 – 29		
7	 Accessories and tools	30		
7.1	Panel heating system accessories	30 – 34		
7.2	Panel heating system tools	35 – 36		
8	 Manifold technology	37		
8.1	Stainless steel manifold	37 – 39		
8.2	Brass manifold	40 – 41		
8.3	Manifold accessories	42 – 43		
8.4	Control manifold	44 – 46		
8.5	Manifold cabinets	47 – 52		
8.6	Complete manifolds	53		
9	 EMPUR® Geniex heat distribution system	54		
9.1	Comfort manager for the heating	54 – 55		
9.2	Planning guide	56 – 57		
9.3	Complete manifold	58 – 59		
9.4	Pump adapter, pump, electronics	60 – 61		
9.5	Complete electro-manifold	61		
9.6	Management	62		
9.7	Operation	63		
9.8	Design accessories	64		
9.9	System accessories	65		
9.10	Heatfixx	66 – 67		
9.11	Service	68 – 69		
10	 Control technology	70		
10.1	Actuators	70		
10.2	Standard heating	71 – 72		
10.3	Balance control terminal strip heating/cooling	73		
10.4	Standard plus heating/cooling	74 – 75		
10.5	Radio	76 – 77		
10.6	Exclusiv radio with Ethernet connection	78		
10.7	Accessories for radio and Exclusiv radio	79		
10.8	Exclusiv BUS with Ethernet connection	80		
10.9	Accessories for radio, radio Exclusiv and BUS	81		
11	 Flat transfer stations	NEW!	82	
11.1	System		82	
11.2	Components		83	
11.3	Basic versions of complete stations		84 – 88	
11.4	System accessories		89	
12	 Industry solutions		90	
12.1	XXL-Industry and EMPUR® concrete core tempering (CCT)		90 – 91	
12.2	System accessories		92 – 93	
13	 Sports floors		94	
13.1	EMPUR® sports floor heating		94 – 95	
14	 eMobility	NEW!	96	
14.1	eparkstation hardware		96 – 98	
14.2	eparkstation software		99	
15	 Insulate properly with EMPUR®		100	
15.1	Minimum thermal insulation (GEG/DIN EN 1264)		100 – 101	
15.2	The PUR philosophy		102 – 103	
15.3	Thermal resistance of the insulation materials (R-value table)		104	
16	 Annex		105	
16.1	Pressure loss diagram for KLIMAPEX® heating pipes		105	
16.2	Services		106 – 107	
16.3	Warranty certificate		108	
16.4	Certificates		109	
16.5	General Terms and Conditions		110 – 111	
16.6	Numerical item index		112 – 115	

Contact persons / Legend



Business Hours:

Mondays to Thursdays:
7.15 am – 5.15 pm
Friday: 7.15 am – 2.15 pm

Tel: +49 2683 96062-0
Fax: +49 2683 96062-99
E-mail: info@empur.com

Managing Director, authorized signatory

Gunther Noll
Tel: +49 2683 96062-0
E-mail: info@empur.com

Sales Manager:

See right-hand page

Contact persons in detail:
www.empur.com/en/contact

Technical Support

Technical quotes, calculations,
configurations, information

Tel: +49 2683 96062-155
Fax: +49 2683 96062-159
E-mail: technik@empur.com

Product Management

Product manager:

Christian Starzetz
Tel: +49 2683 96062-168
E-mail: c.starzetz@empur.com

Quality Management

Head of Quality Management:

Christian Starzetz
Tel: +49 2683 96062-168
E-mail: c.starzetz@empur.com

Manufacturing and Logistics

Operational and Logistics Manager:

Volker Nelles
Tel: +49 2683 96062-146
E-mail: v.nelles@empur.com

Legend (abbreviations)

Term	price list	Datanorm (technique)	Price groups (PG)
Bag	Bag	BTL	01 – Standard
Carton	Car	CT	02 – Tools
Package	Pack		03 – CUT-THERM®
Panel	pnl		04 – Geniix components
Roll	Ro	RO	05 – Geniix services
Piece	unit	PCE	06 – Heatfixx
Drum	Dr		07 – Flat transfer stations
Composite panel	CP	MTR	08 – eMobility
Packing unit	PU	MTK	
Metre	m	KGM	
Square metre	m ²		
Kilogram	kg		
Hour	hr		

Regional Sales

Our sales representatives in Germany can be found on our website www.empur.com

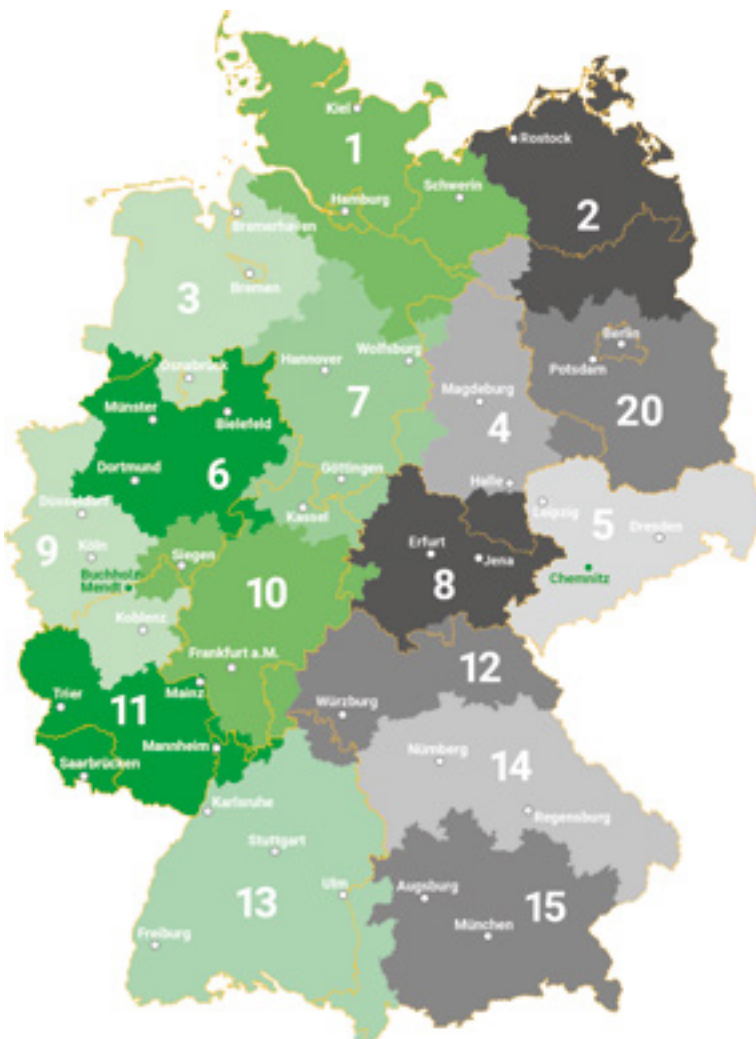

Internal Sales



Sales Export/OEM:

Christian Brenner

Team manager Internal Sales

Phone: +49 2683 96062-117

E-mail: c.brenner@empur.com



Internal sales:

Saskia Pritz

Phone: +49 2683 96062-116

E-mail: s.pritz@empur.com



Internal sales:

Birgit Müller

Phone: +49 2683 96062-114

E-mail: b.mueller@empur.com





Heating pipes

2.1 KLIMAPEX® plastic heating pipes PE-Xa as 5-layer pipe



KLIMAPEX® PE-Xa as 5-layer pipe



The KLIMAPEX® PE-Xa 5-layer pipe is a premium plastic pipe for harsh building site applications. The EVOH barrier layer is guarded against damage by the external PE protective layer. The PE-Xa heating pipe is also produced in a **hook and loop version in-house**.

Item	Item description	PU	Item No.	PG																												
	<p>KLIMAPEX® PE-Xa as 5-layer pipe pipe made of PE-Xa: high-pressure cross-linked polyethylene in accordance with DIN EN ISO 15875 and DIN 16892/16893 Insoluble diffusion-tight EVOH barrier layer in accordance with DIN 4726 Base material: High-density polyethylene</p> <p>Application classes: 4: Underfloor heating, low-temperature heating, radiator connection system 5: High-temperature heating, radiator connection system Maximum loading capacity: Continuous operating temperature + 95°C, short-term excessive temperature (max. 2 years) + 110°C, operating pressure 6 bar 10-year material and consequential damage liability</p>																															
	<table border="1"> <thead> <tr> <th>Dimension</th> <th>Internal Ø</th> <th>Weight approx. 25 kg</th> <th></th> <th></th> </tr> </thead> <tbody> <tr> <td>PE-Xa 15 x 1.8*</td> <td>11.4</td> <td></td> <td>Ro 200 m</td> <td>191532 01</td> </tr> <tr> <td>PE-Xa 17 x 2.0*</td> <td>13.0</td> <td></td> <td>Ro 200 m</td> <td>191732 01</td> </tr> </tbody> </table>	Dimension	Internal Ø	Weight approx. 25 kg			PE-Xa 15 x 1.8*	11.4		Ro 200 m	191532 01	PE-Xa 17 x 2.0*	13.0		Ro 200 m	191732 01																
Dimension	Internal Ø	Weight approx. 25 kg																														
PE-Xa 15 x 1.8*	11.4		Ro 200 m	191532 01																												
PE-Xa 17 x 2.0*	13.0		Ro 200 m	191732 01																												
	* Hook and loop version of the heating pipes in the Exklusiv Klett system (see page 13)																															
	<p>Heating pipes on disposable drum</p> <table border="1"> <thead> <tr> <th>Dimension</th> <th>Internal Ø</th> <th>Weight approx. 70 kg</th> <th></th> <th></th> </tr> </thead> <tbody> <tr> <td>PE-Xa 20 x 2.0</td> <td>16.0</td> <td></td> <td>Dr 600 m</td> <td>192037 01</td> </tr> <tr> <td>PE-Xa 25 x 2.3</td> <td>20.4</td> <td></td> <td>Dr 400 m</td> <td>192534 01</td> </tr> </tbody> </table>	Dimension	Internal Ø	Weight approx. 70 kg			PE-Xa 20 x 2.0	16.0		Dr 600 m	192037 01	PE-Xa 25 x 2.3	20.4		Dr 400 m	192534 01																
Dimension	Internal Ø	Weight approx. 70 kg																														
PE-Xa 20 x 2.0	16.0		Dr 600 m	192037 01																												
PE-Xa 25 x 2.3	20.4		Dr 400 m	192534 01																												
	<p>Heating pipes for EMPUR® pipe dispenser</p> <table border="1"> <thead> <tr> <th>Dimension</th> <th>Internal Ø</th> <th>Core width</th> <th>Core Ø</th> <th>Weight approx. 50 kg</th> <th></th> <th></th> </tr> </thead> <tbody> <tr> <td>PE-Xa 15 x 1.8</td> <td>11.4</td> <td>420 mm</td> <td>260 mm</td> <td></td> <td>Ro 600 m</td> <td>191546 01</td> </tr> <tr> <td>PE-Xa 17 x 2.0</td> <td>13.0</td> <td>420 mm</td> <td>260 mm</td> <td></td> <td>Ro 500 m</td> <td>191745 01</td> </tr> <tr> <td>PE-Xa 20 x 2.0</td> <td>16.0</td> <td>420 mm</td> <td>260 mm</td> <td></td> <td>Ro 400 m</td> <td>192044 01</td> </tr> </tbody> </table>	Dimension	Internal Ø	Core width	Core Ø	Weight approx. 50 kg			PE-Xa 15 x 1.8	11.4	420 mm	260 mm		Ro 600 m	191546 01	PE-Xa 17 x 2.0	13.0	420 mm	260 mm		Ro 500 m	191745 01	PE-Xa 20 x 2.0	16.0	420 mm	260 mm		Ro 400 m	192044 01			
Dimension	Internal Ø	Core width	Core Ø	Weight approx. 50 kg																												
PE-Xa 15 x 1.8	11.4	420 mm	260 mm		Ro 600 m	191546 01																										
PE-Xa 17 x 2.0	13.0	420 mm	260 mm		Ro 500 m	191745 01																										
PE-Xa 20 x 2.0	16.0	420 mm	260 mm		Ro 400 m	192044 01																										
	Pipe dispenser (see page 35)																															

2.2 KLIMAPEX® plastic heating pipes PE-Xa as 3-layer pipe/PE-RT as 5-layer pipe



KLIMAPEX® PE-Xa as 3-layer pipe

The universal pipe for housing – first-class quality for easy installation.

Item	Item description	PU	Item No.	PG																																
	<p>KLIMAPEX® PE-Xa as 3-layer pipe pipe made of PE-Xa: high-pressure cross-linked polyethylene in accordance with DIN EN ISO 15875 and DIN 16892/16893 Insoluble diffusion-tight EVOH barrier layer in accordance with DIN 4726 Base material: High-density polyethylene</p>																																			
	<table border="1"> <thead> <tr> <th>Dimension</th> <th>Internal Ø</th> <th>Core width</th> <th>Core Ø</th> <th>Weight approx. 50 kg</th> <th></th> <th></th> <th></th> </tr> </thead> <tbody> <tr> <td>PE-Xa 15 x 1.8</td> <td>11.4</td> <td>420 mm</td> <td>260 mm</td> <td></td> <td>Ro 600 m</td> <td>191516</td> <td>01</td> </tr> <tr> <td>PE-Xa 17 x 2.0</td> <td>13.0</td> <td>420 mm</td> <td>260 mm</td> <td></td> <td>Ro 500 m</td> <td>191715</td> <td>01</td> </tr> <tr> <td>PE-Xa 20 x 2.0</td> <td>16.0</td> <td>420 mm</td> <td>260 mm</td> <td></td> <td>Ro 400 m</td> <td>192014</td> <td>01</td> </tr> </tbody> </table>	Dimension	Internal Ø	Core width	Core Ø	Weight approx. 50 kg				PE-Xa 15 x 1.8	11.4	420 mm	260 mm		Ro 600 m	191516	01	PE-Xa 17 x 2.0	13.0	420 mm	260 mm		Ro 500 m	191715	01	PE-Xa 20 x 2.0	16.0	420 mm	260 mm		Ro 400 m	192014	01			
Dimension	Internal Ø	Core width	Core Ø	Weight approx. 50 kg																																
PE-Xa 15 x 1.8	11.4	420 mm	260 mm		Ro 600 m	191516	01																													
PE-Xa 17 x 2.0	13.0	420 mm	260 mm		Ro 500 m	191715	01																													
PE-Xa 20 x 2.0	16.0	420 mm	260 mm		Ro 400 m	192014	01																													

KLIMAPEX® PE-RT as 5-layer pipe

The KLIMAPEX® PE-RT 5-layer pipe is a premium plastic pipe for harsh building site applications. The EVOH barrier layer is guarded against damage by the external PE protective layer. The PE-RT heating pipe is also produced in a **hook and loop version in-house**.

Item	Item description	PU	Item No.	PG																														
	<p>KLIMAPEX® PE-RT as 5-layer pipe pipe made of polyethylene, Type I/II in accordance with DIN EN ISO 22391-2 and DIN 16833 Insoluble diffusion-tight EVOH barrier layer in accordance with DIN 4726 Base material: PE-MD with increased thermal stability</p>																																	
	<p>Application classes: 4: Underfloor heating, low-temperature heating, radiator connection system 5: High-temperature heating, radiator connection system High loading capacity: Continuous operating temperature +70°C, short-term excess temperature (max. 2 years) +90°C, operating pressure 4 bar 10-year material and consequential damage liability</p>																																	
	<table border="1"> <thead> <tr> <th>Dimension</th> <th>Internal Ø</th> <th>Weight approx. 25 kg</th> <th></th> <th></th> <th></th> </tr> </thead> <tbody> <tr> <td>PE-RT 12 x 1.5*</td> <td>9.0</td> <td></td> <td>Ro 120 m</td> <td>111231</td> <td>01</td> </tr> <tr> <td>PE-RT 15 x 1.8*</td> <td>11.4</td> <td>pipe, green</td> <td>Ro 200 m</td> <td>111532</td> <td>01</td> </tr> <tr> <td>PE-RT 17 x 2.0*</td> <td>13.0</td> <td></td> <td>Ro 200 m</td> <td>111732</td> <td>01</td> </tr> <tr> <td>PE-RT 20 x 2.0</td> <td>16.0</td> <td></td> <td>Ro 200 m</td> <td>112032</td> <td>01</td> </tr> </tbody> </table>	Dimension	Internal Ø	Weight approx. 25 kg				PE-RT 12 x 1.5*	9.0		Ro 120 m	111231	01	PE-RT 15 x 1.8*	11.4	pipe, green	Ro 200 m	111532	01	PE-RT 17 x 2.0*	13.0		Ro 200 m	111732	01	PE-RT 20 x 2.0	16.0		Ro 200 m	112032	01			
Dimension	Internal Ø	Weight approx. 25 kg																																
PE-RT 12 x 1.5*	9.0		Ro 120 m	111231	01																													
PE-RT 15 x 1.8*	11.4	pipe, green	Ro 200 m	111532	01																													
PE-RT 17 x 2.0*	13.0		Ro 200 m	111732	01																													
PE-RT 20 x 2.0	16.0		Ro 200 m	112032	01																													

* Hook and loop version of the heating pipes in the Exklusiv Klett system (see page 13)

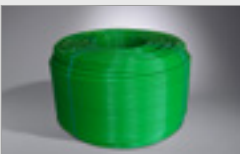
Item	Item description	PU	Item No.	PG																								
	<p>Heating pipes for EMPUR® pipe dispenser Dimension Internal Ø Core width Core Ø Weight approx. 50 kg</p>																											
	<table border="1"> <tbody> <tr> <td>PE-RT 15 x 1.8</td> <td>11.4</td> <td>420 mm</td> <td>260 mm</td> <td>pipe, green</td> <td>Ro 600 m</td> <td>111546</td> <td>01</td> </tr> <tr> <td>PE-RT 17 x 2.0</td> <td>13.0</td> <td>420 mm</td> <td>260 mm</td> <td></td> <td>Ro 500 m</td> <td>111745</td> <td>01</td> </tr> <tr> <td>PE-RT 20 x 2.0</td> <td>16.0</td> <td>420 mm</td> <td>260 mm</td> <td></td> <td>Ro 400 m</td> <td>112044</td> <td>01</td> </tr> </tbody> </table>	PE-RT 15 x 1.8	11.4	420 mm	260 mm	pipe, green	Ro 600 m	111546	01	PE-RT 17 x 2.0	13.0	420 mm	260 mm		Ro 500 m	111745	01	PE-RT 20 x 2.0	16.0	420 mm	260 mm		Ro 400 m	112044	01			
PE-RT 15 x 1.8	11.4	420 mm	260 mm	pipe, green	Ro 600 m	111546	01																					
PE-RT 17 x 2.0	13.0	420 mm	260 mm		Ro 500 m	111745	01																					
PE-RT 20 x 2.0	16.0	420 mm	260 mm		Ro 400 m	112044	01																					

Pipe dispenser (see page 35)



Heating pipes

2.3 KLIMAPEX® plastic heating pipes PE-RT as 5-layer pipe 6 bar version

2.4 Plastic heating pipes PE-RT as 3-layer pipe / metal composite pipe PE-RT/AL/PE-RT

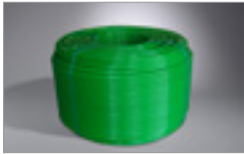

KLIMAPEX® PE-RT as 5-layer pipe 6 bar version

With the KLIMAPEX® PE-RT 6 bar 5-layer pipe, you get a stable plastic pipe, ideal for multi-storey residential construction. The outer protective layer of PE protects the EVOH barrier layer from damage. The PE-RT heating pipe is also produced in a **hook and loop version in-house**.

Item	Item description	PU	Item No.	PG
	KLIMAPEX® PE-RT as 5-layer pipe 6 bar version pipe made of polyethylene, Type II in accordance with DIN EN ISO 22391-2, insoluble diffusion-tight EVOH barrier layer in accordance with DIN 4726, quality-controlled; Base material: PE-MD with increased thermal stability Application classes: 4: Underfloor heating, low-temperature heating, radiator connection system 5: High-temperature heating, radiator connection system High loading capacity: Continuous operating temperature +70°C, short-term excess temperature (max. 2 years) +90°C, operating pressure 6 bar, 10-year material and consequential damage liability	 K 1693		
	Dimension	Internal Ø	Weight approx. 25 kg	
6 bar version	PE-RT 15 x 1,8	11,8	pipe, green	Ro 200 m 111552 01
	PE-RT 15 x 1,8	11,8	pipe, green	Ro 600 m 111556 01
	PE-RT 17 x 2,0	13,0		Ro 200 m 111752 01
	PE-RT 17 x 2,0	13,0		Ro 500 m 111755 01

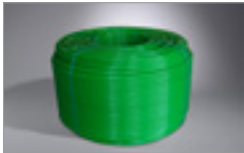

KLIMAPEX® PE-RT as 3-layer pipe

The universal pipe for housing – first-class quality for easy installation.

Item	Item description	PU	Item No.	PG
	KLIMAPEX® PE-RT as 3-layer pipe pipe made of polyethylene, Type I/II in accordance with DIN EN ISO 22391-2 and DIN 16833, with increased thermal stability and insoluble diffusion-tight EVOH barrier layer in accordance with DIN 4726 Base material: PE-MD with increased thermal stability	 3V 204 PE-RT		
	Dimension	Internal Ø	Core width	Core Ø
	PE-RT 15 x 1.8	11.4	420 mm	260 mm
	PE-RT 17 x 2.0	13.0	420 mm	260 mm
				Weight approx. 50 kg
				pipe, green
				Ro 600 m 111516 01
				Ro 500 m 111715 01

KLIMAPEX® metal composite pipe PE-RT/AL/PE-RT

The composite pipe in Optimal II dry construction system (see from page 16)

Item	Item description	PU	Item No.	PG
	KLIMAPEX® metal composite pipe PE-RT/AL/PE-RT consisting of an internal and external PE-RT pipe, in accordance with DIN EN ISO 21003-2 and DIN 16836, very flexible, sturdy and oxygen-tight according to DIN 4726 through the internal butt-welded aluminium layer Application classes: 4: Underfloor heating, low-temperature heating, radiator connection system 5: High-temperature heating, radiator connection system Maximum loading capacity: Continuous operating temperature + 95 °C, short-term excessive temperature (max. 2 years) + 110 °C, operating pressure 6 bar, 10-year material and consequential damage liability	 A 765		
	Dimension	Internal Ø	Core width	Core Ø
	16 x 2.0	12.0		
	16 x 2.0	12.0	420 mm	260 mm
				Weight approx. 50 kg
				pipe, green
				Ro 200 m 171602 01
				Ro 500 m 171615 01

NOTE Compression fittings for heating pipes (see page 30)

KLIMAPEX® PE-Xa heating pipe as a 5-/3-layer pipe	in accordance with DIN EN ISO 15875	
Continuous operating temperature	+ 95°C	
max. operating pressure	6 bar	
Smallest bending radius	5 x d	DIN 4726
Optimal processing temperature	- 5°C to 30°C	DIN 16892
Minimum degree of cross-linking	≥ 70%	DIN 16892
Thermal conductivity	0.35 W/mK	DIN EN 12664
Coefficient of linear expansion	$1.4 \cdot 10^{-4} K^{-1}$	
Oxygen tightness	≤ 0.32 mg/(m ² · d) at 40°C (application class 4)	DIN 4726

KLIMAPEX® PE-RT heating pipe as a 5-/3-layer pipe	in accordance with DIN EN ISO 22391-2	
Continuous operating temperature	+ 70°C	
Max. operating pressure	4 or 6 bar depending on type	
Smallest bending radius	5 x d	DIN 4726
Optimal processing temperature	- 5°C to 30°C	DIN 16833
Thermal conductivity	0.35 W/mK	DIN EN 12664
Coefficient of linear expansion	$1.4 \cdot 10^{-4} K^{-1}$	
Oxygen tightness	≤ 0.32 mg/(m ² · d) at 40°C (application class 4)	DIN 4726

KLIMAPEX® metal composite pipe PE-RT/AL/PE-RT	in accordance with DIN EN ISO 21003-2	
Continuous operating temperature	+ 70°C	
Max. operating pressure	6 bar	
Smallest bending radius	5 x d	DIN 4726
Optimal processing temperature	- 5°C bis 30°C	DIN 16833
Thermal conductivity	0.42 W/mK	DIN EN 12664
Coefficient of linear expansion	$2.5 \cdot 10^{-5} K^{-1}$	
Oxygen tightness	≤ 0.32 mg/(m ² · d) at 40°C (application class 4)	DIN 4726

Internal diameter/water volume of KLIMAPEX® plastic heating pipes:

Dimensions	Internal diamete	Water volume
10 x 1.3 mm	7.4 mm	0.043 l/m
12 x 1.5 mm	9.0 mm	0.064 l/m
14 x 2.0 mm	10.0 mm	0.078 l/m
15 x 1.8 mm	11.4 mm	0.102 l/m
16 x 2.0 mm	12.0 mm	0.113 l/m
17 x 2.0 mm	13.0 mm	0.133 l/m
20 x 2.0 mm	16.0 mm	0.201 l/m
25 x 2.3 mm	20.4 mm	0.327 l/m

Areas of application in accordance with ISO 10508:

Panel heating and radiator connections

Classification:

Application class 4:

Underfloor heating, low-temperature heating, radiator connection system.

Application class 5:

High-temperature radiator heating.

NOTE

KLIMAPEX® heating pipes must be protected against sunlight during transportation and storage.

Other dimensions available on request

Underfloor heating systems in new builds





3.1 PUR-THERM® stapler system



PUR-THERM® stapler system

The EMPUR® PUR-THERM® stapler system is a **proven and well-known panel heating system**, consisting of PUR-THERM® composite panels, KLIMAPEX® plastic heating pipes and PUR-THERM® staples as its main components.

The PUR-THERM® composite panels are HBCD and CFC-free and available in different versions (polyurethane, EPS, with and without sound absorption). As a result of their highly tear-resistant multi-layer laminated film, **excellent affixing** of the staples is achieved when installing the heating pipes. A predefined laying grid as well as a single-sided film overhang for **overlapped laying** makes stapling very easy. To ensure good heat transfer, the heating pipe is uniformly covered with screed.

Item	Item description	Thickness (mm)	R-value m ² K/W	PU m ²	Item No.	PG
	Composite panel PUR/PE 14 "Exclusiv" Compressive stress/strength up to 5 kPa Format: 2,000 x 1,000 mm → 2.0 m ² single-sided film overhang	14 (9+5)	0.545	Pack 20	041400	01
	Composite panel PUR/PE 23 "Exclusiv" Compressive stress/strength up to 5 kPa Format: 2,000 x 1,000 mm → 2.0 m ² single-sided film overhang	23 (13+10)	0.780	Pack 10	042300	01
	Composite panel PUR "Exclusiv" Compressive stress/strength ≥100 kPa Format: 2,000 x 1,000 mm → 2.0 m ² single-sided film overhang	23 33 40	0.958 1.378 1.667	Pack 10 Pack 10 Pack 10	042400 043400 044000	01 01 01
	Composite panel PUR/PE "Exclusiv" Compressive stress/strength ≥100 kPa Format: 2,000 x 1,000 mm → 2.0 m ² single-sided film overhang	36 (31+5) 68 (63+5)	1.562 2.950	Pack 10 Pack 6	043150 046350	01 01

**No longer included in the product range!
Please contact us for alternatives.**

**No longer included in the product range!
Please contact us for alternatives.**



**No longer included in the product range!
Please contact us for alternatives.**

**No longer included in the product range!
Please contact us for alternatives.**

Underfloor heating systems in new builds

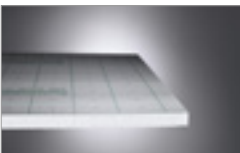
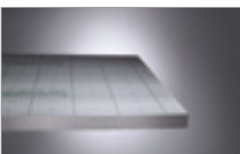
3.1 PUR-THERM® stapler system

Item	Item description	Thickness (mm)	R-value m ² K/W	PU m ²	Item No.	PG
	Turbo-Cube EPS-DES sm	20-2	0.444	Pack 12	022012	01
	WLS 045	25-2	0.556	Pack 12	022512	01
	Compressive stress/strength up to 4 kPa	30-3	0.667	Pack 12	023012	01
	Format: 12,000 x 1,000 mm = 12 m ² pack	35-3	0.778	Pack 12	023512	01
	Composite panel "Objekt" EPS-DES sm	20-2	0.444	Pack 10	022010	01
	WLS 045	25-2	0.556	Pack 10	022510	01
	Compressive stress/strength up to 4 kPa	30-3	0.667	Pack 10	023010	01
	Format: 2,000 x 1,000 mm = 2 m ²	35-3	0.778	Pack 10	023510	01
	Composite panel/Turbo-Cube "V5" EPS-DES sg					
	WLS 040					
	Compressive stress/strength up to 5 kPa	30-2	0.750	Pack 10	023020	01
	Format: 2,000 x 1,000 mm = 2 m ²	30-2	0.750	Pack 12	023022	01
	Composite panel "V5" EPS-DES sg					
	WLS 032					
	Compressive stress/strength up to 5 kPa	25-2	0.781	Pack 10	022525	01
	Format: 2,000 x 1,000 mm = 2 m ²	30-2	0.938	Pack 10	023025	01
	Composite panel "Kompakt" EPS-DEOdm					
	WLS 032					
	Compressive stress/strength ≥ 100 kPa for high compressive stresses	20	0.625	Pack 10	022060	01
	Format: 2,000 x 1,000 mm = 2 m ²	30	0.938	Pack 10	023060	01

Item	Item description	PU	Item No.	PG
	Long staples			
	for PUR-THERM® stapler system for pipes up to Ø 20 mm, green, 50-unit magazines	Car = 1.000 units	911001	01
	Short staples			
	for PUR-THERM® stapler system, for pipes up to Ø 20 mm, black, 50-unit magazines	Car = 1.000 units	911000	01
	PUR-THERM® system tacker			
	precise, low-wear tool for handling magazine-loaded staples, with curved magazine and ergonomic grip			
	Total height approx. 82 cm (handle above staple surface)	1 unit	991010	02
	PUR-THERM® system tacker extension			
	for ergonomic adjustment of the working height, consisting of extension of approx. 10 cm and two screws	1 unit	991011	02

Underfloor heating systems in new builds

3.2 Exclusiv-Klett system







7F364-F

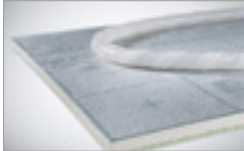

Exclusiv-Klett system

The EMPUR® Exclusiv-Klett system is an innovative application type. It uses **intelligent hook and loop technology** to connect the EMPUR® composite panels with the KLIMAPEX® Klett plastic heating tubes.

After the **laminated composite panels** with one-sided film overhang have been laid, the hook and loop pipe is fixed to the surface with light pressure, according to the **pre-printed laying grid** and the distance required. The hook and loop tape has **excellent adhesion properties**, but can be removed and pressed on again to correct the position of the composite panels. To ensure good heat transfer, the heating pipe is uniformly covered with screed.









Item	Item description	PU	Item No.	PG
	Composite panel PUR/PE 15 "Exclusiv-Klett" Compressive stress/strength up to 5 kPa. Format: 2,000 x 1,000 mm = 2.0 m ² , Single-sided film overhang Thickness (mm) 15 (10 + 5) R-value [m ² K/W] 0.584	Pack 20 m ²	070414	01
	Composite panel PUR 23 "Exclusiv-Klett" Compressive stress/strength ≥100 kPa. Format: 2,000 x 1,000 mm = 2.0 m ² , Single-sided film overhang Thickness (mm) 23 R-value [m ² K/W] 0.958	Pack 10 m ²	070424	01
	Composite panel "Klett" EPS-DES sm/sg Format: 2,000 x 1,000 mm = 2.0 m ² Thickness (mm) R-value [m ² K/W] Compressive stress WLS			
	20-2 sm 0.444 4 kPa 045	Pack 10 m ²	070220	01
	30-2 sg 0.750 5 kPa 040	Pack 10 m ²	070232	01
	Turbo Cube "Klett" EPS-DES sm/sg Format: 12,000 x 1,000 mm = 12.0 m ² Thickness (mm) R-value [m ² K/W] Compressive stress WLS			
	20-2 sm 0.444 4 kPa 045	Pack 12 m ²	070320	01
	25-2 sm 0.556 4 kPa 045	Pack 12 m ²	070325	01
	30-2 sg 0.750 5 kPa 040	Pack 12 m ²	070332	01
	30-3 sm 0.667 4 kPa 045	Pack 12 m ²	070330	01
	35-3 sm 0.778 4 kPa 045	Pack 12 m ²	070335	01

No longer included in the product range!
Please contact us for alternatives.

No longer included in the product range!
Please contact us for alternatives.

Underfloor heating systems in new builds

3.2 Exclusiv-Klett system

Item	Item description	PU	Item No.	PG
	Composite panel "Klett-Kompakt" EPS-DEO dm Format: 2,000 x 1,000 mm = 2.0 m ² , Compressive stress/strength ≥ 100 kPa for high compressive stresses Thickness (mm) R-value [m ² K/W] WLS 30 0.938 032	Pack 10 m ²	070236	01
	Fibre panel "Klett" 2.6 mm with 2,400 x 1,000 mm (2.4 m ²) velcro-bonded non-woven film with one-sided film overhang, can be applied to clean, level, dry and solid substrates or to additional insulation as a mounting plate, compressive strength ≥ 150 kPa, for high pressure load Can only be combined with cement screed! Follow installation and processing instructions!	Pack 7.2 m ²	070503	01
	KLIMAPEX® PE-Xa heating pipes "Klett" pipe made of PE-Xa: high-pressure cross-linked polyethylene in accordance with DIN EN ISO 15875, Base material: high-density polyethylene, degree of cross-linking in accordance with DIN 4726, insoluble diffusion-tight EVOH barrier layer Dimension Internal Ø (see page 6)	Ro 200 m Ro 600 m Ro 200 m Ro 500 m	071592 071596 071792 071795	01 01 01 01
	KLIMAPEX® PE-RT heating pipes "Klett" pipe made of polyethylene, Type I/II, in accordance with DIN EN ISO 22391-2 and DIN 16833 with insoluble diffusion-tight EVOH barrier layer in accordance with DIN 4726 (see pages 7-8), base material: PE-MD with increased thermal stability Dimension Internal Ø	Ro 120 m Ro 200 m Ro 600 m Ro 200 m Ro 500 m	071211 071512 071516 071712 071715	01 01 01 01 01
	Connecting tape for strong and positive connection of Exclusiv composite panels and additional fixing of pipelines, 30 mm wide	Ro 100 m	070001	01
	Laying gloves "Klett" size 10	1 set	990060	02
	LAYING TOOLS Door tensioner with rotating bezel, open, Extending length min. 570 mm – max. 960 mm	1 unit	990200	02
	Ceiling tensioner unit with rotating bezel, open, adjustable from min. 1,650 mm to max. 2,800 mm	1 unit	990210	02

Further system components (see pages 30-36)

Underfloor heating systems in new builds



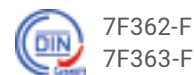

3.3 top-Nopp® nub system



top-Nopp® nub system 15-17

The EMPUR® top-Nopp® system components consist of a completely foam-backed, wear-resistant dimpled film and are perfectly supplemented with the KLIMAPEX® high-quality plastic heating pipes in the sizes 15-17 mm.

The **double-sided film overhang** enables neat laying of the panels. The components can be connected easily and with minimum material loss using the **press stud method** afforded by the male and female nubs, which are arranged in a single row. The KLIMAPEX® plastic heating pipes are clicked into the nub structure and fastened using **perfectly fitting pipe retaining nubs**. The **laying grid** is indicated by the arrangement of the nubs and makes it significantly easier to keep to the layout distances. To ensure good heat transfer, the heating pipe is uniformly covered with screed (underfloor heating design type A according to DIN 18560).

Item	Item description	PU	Item No.	PG
	Castellated panel top-Nopp® 11, EPS-DEO only for 15-17 mm pipes in accordance with EN 13163 without sound absorption , Format: 1,025 x 1,025 mm (useful surface 1 m²), installation clearance 90° axially 50 mm, 45° diagonally 70 mm, insulation thickness 11 mm, overall height 30 mm, WLS 035, R = 0.314 m² K/W, compressive stress/strength 100 kPa, fully-foamed castellations, with doublesided film overhang	pnI 20 = 20 m²	081120	01
	Castellated panel top-Nopp® 30-2, EPS-DES only for 15-17 mm pipes Polystyrene castellated panel in accordance with EN 13163 with sound absorption , Format: 1,025 x 1,025 mm (useful surface 1 m²), installation clearance 90° axially 50 mm, 45° diagonally 70 mm, insulation thickness 30 mm, Overall height 49 mm, WLS 040, R = 0.75 m² K/W, compressive stress/ strength 5 kPa, fully-foamed castellations, with double-sided film overhang	pnI 10 = 10 m²	083020	01
	Castellated element top-Nopp® only for 15-17 mm pipes Polystyrene castellated element, CFC-free, without insulation Format: 1,025 x 1,025 mm (useful surface 1 m²), installation clearance 90° axially 50 mm, 45° diagonally 70 mm, castellation height 19 mm	pnI 20 = 20 m²	080020	01
	Connector strips top-Nopp® for TN 11/30-2 only for 15-17 mm pipes Connector strips without insulation as connectors in snap-fastening systems, format: 1,000 x 100 mm	10 units	080021	01

No longer included in the product range!

Underfloor heating systems in new builds

3.3 top-Nopp® nub system

Item	Item description	PU	Item No.	PG
	Door and levelling element top-Nopp® for TN 11/30-2, set only for 15-17 mm pipes consisting of: 10 door elements 965 mm x 150 mm, two levelling elements 1,150 mm x 500 mm	1 set	080022	01
	Round section top-Nopp® Diameter: 18 mm for attaching edge insulation strips to the castellated panel	Ro 25 m	089900	01
	Expansion gap section top-Nopp® Format: 100 mm high x 1,800 mm long made of PE, wedge-shaped for the castellated panel, with adhesive strips, in accordance with DIN 18560	20 units = 36 m	901012	01
	Floor insulation panel EPS DEO dm (without sound insulation) as additional insulation top-Nopp® 11 Format: 1,000 mm x 500 mm x 10 mm, WLS 035, Additional insulation $R=0.286 \text{ m}^2 \text{ K/W}$, Compressive stress/strength $\geq 100 \text{ kPa}$	Pack 6 m^2 Pack 24 m^2	080047 011035	01 01
	Impact sound insulation EPS DES sg as additional insulation top-Nopp® 30-2 Format: 1,000 mm x 1,000 mm x 30 mm, WLS 040, $R=0.750 \text{ m}^2 \text{ K/W}$, Compressive stress/strength up to 5 kPa	Pack 15 m^2	013015	01
	Expansion joint protective pipe for pipes up to $\varnothing 18 \text{ mm}$, length 400 mm, slotted outside \varnothing approx. 25 mm	Bag 10 Stk	918400	01
	Expansion joint protective pipe on roll for pipes up to $\varnothing 18 \text{ mm}$, length 25 m, unslotted for pipes up to $\varnothing 18 \text{ mm}$, length 25 m, slotted outside \varnothing approx. 25 mm	1 Ro 1 Ro	918500 918600	01 01
	Cutting tool set for top-Nopp® system elements specially adapted to the castellation geometry with ergonomic grip	1 unit	910050	02

Exemplary overall structure

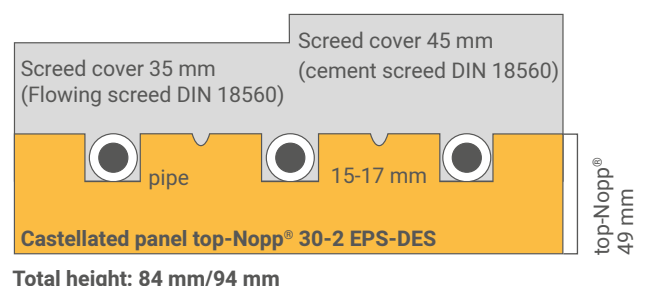
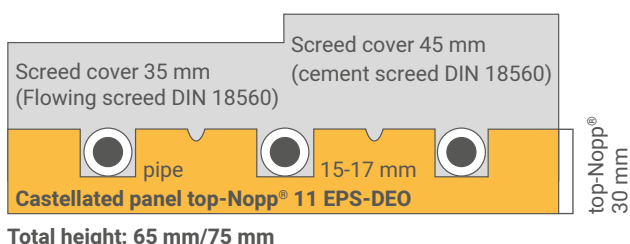

NOTE Additional insulation (see page 18)

Other dimensions available on request

Underfloor heating systems in new builds

3.4 OPTIMAL II dry construction system







7F385-F



OPTIMAL II dry construction system

The OPTIMAL II dry construction system by EMPUR® is useful wherever a **low weight** is required due to structural reasons or where dry screed components are being used. The system consists of hard foam panels of the highest rigidity and **foam incorporated grooves and pipe redirectors**. The **aluminium/steel heat conducting plates** that are to be inserted ensure quick even heat distribution. The dry screed **load distribution layer** can be placed into position immediately after the pipes have been laid. The system panel can be used in many layouts. **Also ideal as wall panel heating in renovation projects (vertical wet-system wall heating, see pages 25-27) with plasterboard walls 9.5 – 25 mm, which can be fixed onto the elements.**

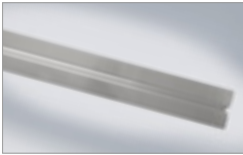





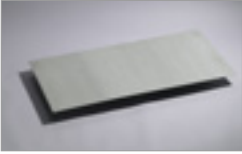

Structural heights: Floor ≥ 55 mm, wall ≥ 40 mm. Suitable weight distribution layers: Dry screed plates 18-25 mm

Item	Item description	PU	Item No.	PG
	System panel RA 12.5/RA 25, WLS 035 1,000 x 600 x 30 mm = 0.6 m ² /pnl, R=0.857 m ² K/W. Compressive stress/strength up to 200 kPa, universal panel for laying doorways and redirections	10 pnl = 6 m ²	030420	01
	Aluminium baffle RA 12.5 For insertion into system panel	25 units	030421	01
	Aluminium heat conduction plate for high thermal output with 2 predetermined breaking points, dimensions: 750 x 120 mm Requirement: VA 125 > 7.5 m/m ² 10 units VA 250 > 3.75 m/m ² 5 units	40 units = 30 m	030424	01
	Galvanised heat conduction plate with 5 predetermined breaking points, dimensions: 750 x 120 mm Requirement: VA 125 > 7.5 m/m ² 10 units VA 250 > 3.75 m/m ² 5 units	50 units = 37.5 m	030423	01

The specific performance of the dry construction system with galvanised heat conduction plates is approximately 30% below that of the dry construction system with aluminium heat conduction plates.

Underfloor heating systems in new builds

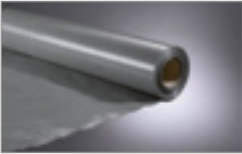
3.4 OPTIMAL II dry construction system

Item	Item description	PU	Item No.	PG
	Load sharing element for doorway made of galvanised sheet steel, 1,000 x 500 x 0.5 mm	1 unit	030100	01
	KLIMAPEX® PE-RT metal composite pipe Multi-layer composite pipe with welded aluminium jacket, aluminium layer as oxygen barrier, diffusion-tight according to DIN 4726 Dimension Internal Ø Core width Core Ø 16 x 2.0 12.0 16 x 2.0 12.0 420 mm 260 mm Compression fitting 16 x 2,0 especially for aluminium composite pipe	 Ro 200 m Ro 500 m Bag 10 units	171602 171615 621600	01 01 01
	Flexible springs for the precise bending of metal composite pipes, up to Ø 16 mm external internal	1 unit 1 unit	961216 961116	02 02
	Floor insulation panel EPS DEO dm (without sound absorption) WLS 035, Compressive stress/strength ≥100 kPa, Format: 1,000 x 500 mm, Thickness: 30 mm, R-value: 0.857 m² K/W	Pack 8 m²	013035	01
	Self-adhesive edge insulation strips, green Description as on page 32 but with additional adhesive fixing on the foam backing for mounting to dry, smooth, level rising structures (e.g. plasterboard) 8 x 150 mm	Ro 50 m	908159	01
	PE cover sheeting Web width 2 m, length 50 m	Ro 100 m²	900020	01
	Hot cutting tool for OPTIMAL II dry construction systems for cutting pipe grooves into insulation panels Complete set in the bag with groove cutting tip N-1, R = 9 mm, W/D = 18 mm and cutting tip C, L = 35 mm, 3 m mains supply with contoured central plug	1 unit	030230	02

Exemplary overall structure

Underfloor heating system with 20 mm dry screed panels

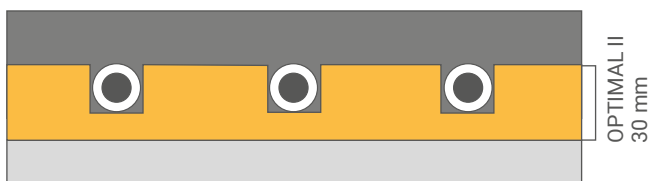

Total height: 50 mm

Underfloor heating system with anhydride screed 35 mm

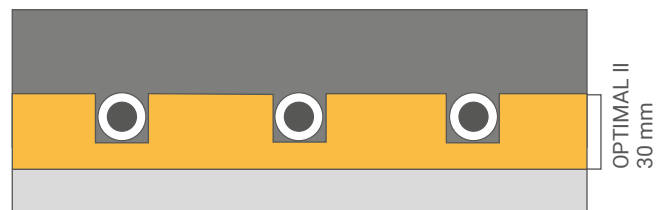

Total height: 65 mm

NOTE

Screed, height and quality are to be tested for each individual case according to the site requirements!
Laying and application instructions of the dry screed elements have to be considered!

Underfloor heating systems in new builds

3.5 Additional insulation

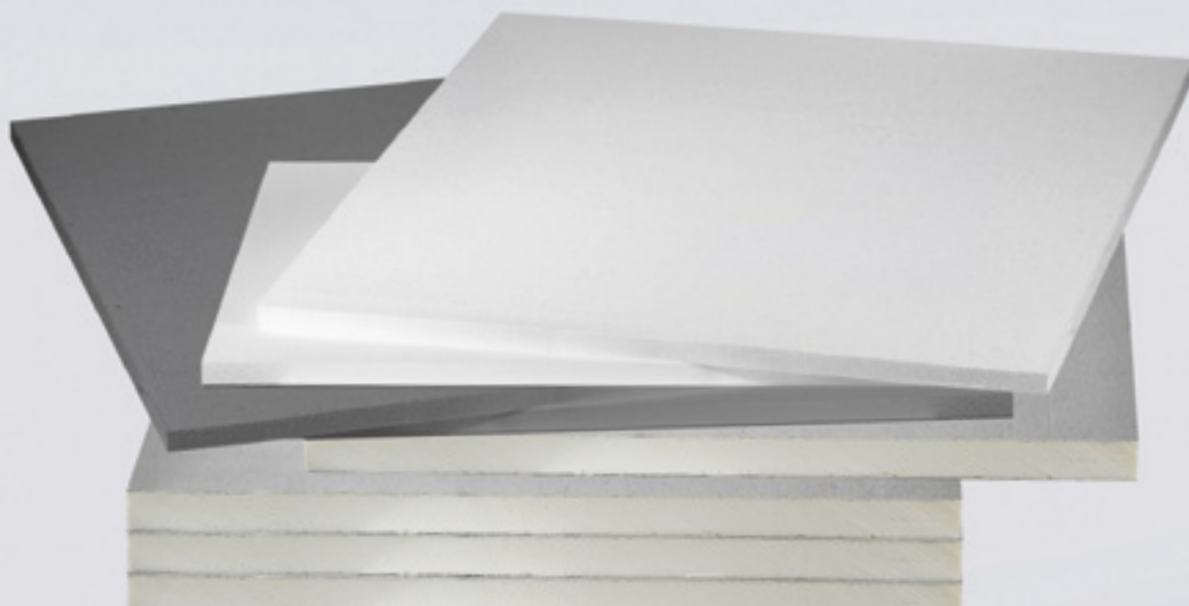

Additional insulation

In order to enable all types of system structures, EMPUR® also offers **heat-insulation panels made from polyurethane in accordance with EN13165 and polystyrene in accordance with EN13163** as additional insulation without a grid film and impact noise reduction, in addition to the various PUR-THERM® composite panels. These can be used under floating screed as ceiling or wall insulation. All products are HBCD and CFC-free.

Item	Item description	Thickness	R-value m ² K/W	PU m ²	Item No.	PG
	Polyurethane insulation panels (without sound absorption) PUR panels WLS 024 i.e.w. EN 13165 double-sided aluminum cladding with smooth edges, type DEO dm Compressive stress/strength ≥ 100 kPa, Format: 1,200 x 600 mm	20 mm	0.833	Pack 7.2	002006	01
		30 mm	1.250	Pack 7.2	003006	01
		40 mm	1.666	Pack 7.2	004006	01
		47 mm	1.958	Pack 7.2	004706	01
		53 mm	2.208	Pack 7.2	005306	01
	Floor insulation panel EPS DEO dm (without sound absorption) WLS 032 Compressive stress/strength ≥ 100 kPa Format: 1,000 x 500 mm	10 mm	0.313	Pack 24	011065	01
		20 mm	0.625	Pack 12	012065	01
		30 mm	0.938	Pack 8	013065	01
		40 mm	1.250	Pack 6	014065	01
		50 mm	1.563	Pack 4.5	015065	01
		60 mm	1.875	Pack 4	016065	01
	Floor insulation panel EPS DEO dm (without sound absorption) WLS 035 Compressive stress/strength ≥ 100 kPa Format: 1,000 x 500 mm	20 mm	0.571	Pack 12	012035	01
		30 mm	0.857	Pack 8	013035	01
		40 mm	1.143	Pack 6	014035	01
		50 mm	1.429	Pack 4.5	015035	01
		60 mm	1.714	Pack 4	016035	01
	Floor insulation panel EPS DES dm (without sound absorption) WLS 040 Compressive stress/strength up to 100 kPa Format: 1,000 x 500 mm	30 mm	0.750	Pack 8	013045	01
		50 mm	1.250	Pack 4.5	015045	01
		60 mm	1.500	Pack 4	016045	01
	Sound insulation panel EPS DES sm WLS 045 Compressive stress/strength up to 4 kPa Format: 1,000 x 1,000 mm	20-2 mm	0.444	Pack 22	012000	01
		25-2 mm	0.556	Pack 18	012500	01
		30-3 mm	0.667	Pack 15	013000	01
	Sound insulation panel EPS DES sg WLS 040 Compressive stress/strength up to 5 kPa Format: 1,000 x 1,000 mm	35-3 mm	0.778	Pack 13	013500	01
		30-2 mm	0.750	Pack 15	013015	01

No longer included in the product range!

Underfloor heating systems for modernisation projects

4.1 CUT-THERM® milling system



CUT-THERM® milling system

CUT-THERM® is the **quick solution system** by EMPUR® that cuts a floor heating system into existing floors **without causing damage or changing the existing screed level**.

An experienced EMPUR® installation team uses a **special floor milling machine** to cut grooves for the heating pipes into the existing screed, **with virtually no dust** (cement or anhydrite screed with a minimum thickness of 40 mm). Thus the floor lining can be placed into position immediately after the pipes have been laid into the grooves. Before the work is carried out, a pilot hole needs to be drilled in the screed by a skilled tradesperson. The grooves are cut directly into the existing screed, also in new builds! The construction requirements are reduced to a minimum. **No floor core refurbishment is required.**

* All necessary tools and energies are brought along if necessary.

** The heating pipes are connected exclusively to EMPUR® manifolds by our installation team. Connection to the existing heating system is carried out by the specialised company.

CUT-THERM® Scope

An experienced CUT-THERM® Installation Team* carries out the following services:

- Cutting of grooves into the existing screed at a laying distance of 12.5 cm (other distances after technical clarification)
- Laying of the floor heating pipes into the grooves
- Connection of the floor heating pipes to the manifold**
- Leakage test with air according DIN EN 1264

Included in the scope of delivery:

- KLIMAPEX® PE-RT 15 x 1.8 mm (green)
- HCM-D (variant 1) or HCM-R (variant 2) made from brass, **advance shipment to the specialised tradesman for installation**
- Compression fittings and connection set passage-way/90°
- Angle brace for supply and return lines if necessary

With CUT-THERM® you are always on time

Example: Modernisation of living space up to 120 m²/day, depending on structural conditions and nature of the substrate to be milled

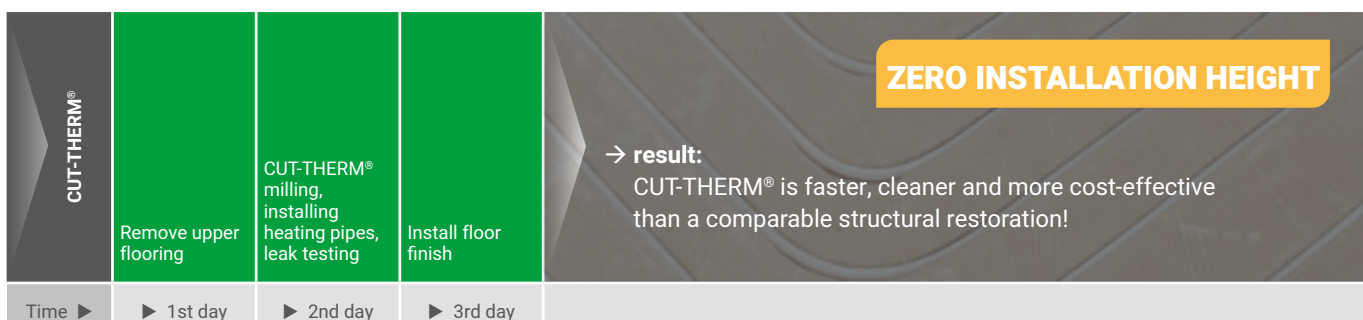

Underfloor heating systems for modernisation projects

4.1 CUT-THERM® milling system

Variant 1, HCM-D (incl. connection set 90°): includes all the services listed in the quote

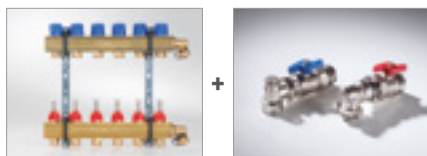

Variant 2, HCM-DR (incl. high-efficiency pump, thermo-separator, connection set 90° with line regulating valve and ruleset K): includes all the services listed in the quote



Heating circuits	Main heating surface	Item No.	PG
HCM-D 1	up to 10 m ²	092201	03
HCM-D 2	up to 20 m ²	092202	03
HCM-D 3	up to 30 m ²	092203	03
HCM-D 4	up to 40 m ²	092204	03
HCM-D 5	up to 50 m ²	092205	03
HCM-D 6	up to 60 m ²	092206	03
HCM-D 7	up to 70 m ²	092207	03
HCM-D 8	up to 80 m ²	092208	03
HCM-D 9	up to 90 m ²	092209	03
HCM-D 10	up to 100 m ²	092210	03
HCM-D 11	up to 110 m ²	092211	03
HCM-D 12	up to 120 m ²	092212	03
HCM-D 13	up to 130 m ²	092213	03
HCM-D 14	up to 140 m ²	092214	03
HCM-D 15	up to 150 m ²	092215	03
HCM-D 16	up to 160 m ²	092216	03
HCM-D 17	up to 170 m ²	092217	03
HCM-D 18	up to 180 m ²	092218	03
HCM-D 19	up to 190 m ²	092219	03
HCM-D 20	up to 200 m ²	092220	03
HCM-D 21	up to 210 m ²	092221	03
HCM-D 22	up to 220 m ²	092222	03
HCM-D 23	up to 230 m ²	092223	03
HCM-D 24	up to 240 m ²	092224	03
HCM-D 25	up to 250 m ²	092225	03

Heating circuits	Main heating surface	Item No.	PG
HCM-DR 2	up to 20 m ²	092502	03
HCM-DR 3	up to 30 m ²	092503	03
HCM-DR 4	up to 40 m ²	092504	03
HCM-DR 5	up to 50 m ²	092505	03
HCM-DR 6	up to 60 m ²	092506	03
HCM-DR 7	up to 70 m ²	092507	03
HCM-DR 8	up to 80 m ²	092508	03
HCM-DR 9	up to 90 m ²	092509	03
HCM-DR 10	up to 100 m ²	092510	03
HCM-DR 11	up to 110 m ²	092511	03
HCM-DR 12	up to 120 m ²	092512	03
HCM-DR 13	up to 130 m ²	092513	03
HCM-DR 14	up to 140 m ²	092514	03
HCM-DR 15	up to 150 m ²	092515	03
HCM-DR 16	up to 160 m ²	092516	03

Example tables: Precondition for the order is the calculation of the surface heating by EMPUR®, Technical Services Department. Brass manifold HCM-D 1 to 16 in version 1" (max. 1,8 m³/h); HCM-D 17 to 25 in version 5/4" (max. 3 m³/h). Brass manifold HCM-DR 1 to 9 in version 1"; HCM-DR 10 to 16 in version 5/4". A separate rebate applies for the CUT-THERM® modernization system.

NOTE

Illustrations only include the main components. Accessories included in the scope of delivery are not shown.

Complete your CUT-THERM® range with further EMPUR® products such as a manifold cabinet and control technology in order to enjoy a self-contained EMPUR® system. We'd be pleased to advise you!

Underfloor heating systems for modernisation projects

4.2 top-Nopp® mini nub system



top-Nopp® mini nub system

The EMPUR® top-Nopp® mini system components consist of a **wear-resistant, deep-drawn castellated film** and are perfectly supplemented with the KLIMAPEX® high-quality plastic heating pipes. The “mini nub system” can be used whenever a **low installation height** is required.

The **system plates are available in two versions for pipe 12 x 1.5 and 15 x 1.8**, both with holes in the nubs for an optimum distribution of the levelling compound. Following pre-treatment (priming) with the required levelling compound, the system is installed as a **composite structure** onto the existing floor lining or raw floor, but not directly onto concrete floors. During installation the nub panel is fixed to the floor with an adhesive layer underneath it. The **double-sided film** overhang enables neat laying of the panels. The components can be **connected easily**, with minimum material loss and in a short time using the press stud method afforded by the male and female nubs, which are arranged in a single row.

The KLIMAPEX® plastic heating pipes are clicked into the nub structure and fastened using **perfectly fitting pipe retaining nubs**. Thanks to the ideal nub arrangement, the heating tubes can be positioned at different layout distances with **ease and flexibility**. The heating pipe is uniformly covered with special, **thin-layer screed**.

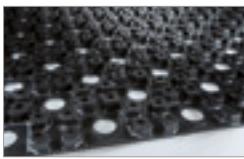
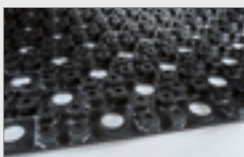







Item	Item description	PU	Item No.	PG
	Castellated element top-Nopp® mini for 12 mm pipe Polystyrene castellated element, B2/E, CFC-free, without insulation, rear adhesive layer with removable protective film Format: 1,025 x 1,025 mm (useful surface 1 m ²) installation clearance 90° axially 50/100/150 mm, 45° diagonally 70/140/210 mm Castellation height: 13 mm	10 pnl = 10 m ²	080050	01
	Castellated element top-Nopp® mini for 15 mm pipe Polystyrene castellated element, B2/E, CFC-free, without insulation, rear adhesive layer with removable protective film Format: 725 x 1,025 mm (useful surface 0.70 m ²) installation clearance 90° axially 50/100/150 mm, 45° diagonally 70/140/210 mm Castellation height: 17 mm	10 pnl = 7 m ²	080051	0

NOTE

The system is installed as a composite construction on even and stable subfloors after the subfloor has been prepared/primed (match to levelling compound and subfloor!) and with the appropriate levelling compound directly on the existing floor covering or unfinished floor, **but not directly on concrete**.

Underfloor heating systems for modernisation projects

4.2 top-Nopp® mini nub system

Item	Item description	PU	Item No.	PG
	KLIMAPEX® heating pipe PE-RT as a 5-layer pipe (see page 7)	 3V 204 PE-RT		
	Dimension Internal Ø Weight approx. 25 kg			
	PE-RT 12 x 1.5 9.0 PE-RT 15 x 1.8 11.4 pipe, green		Ro 120 m 111231 01 Ro 200 m 111532 01	
	Expansion gap section in accordance with DIN 18560, made of PE / PET 40 / 10 mm black with levelling base and adhesive strips and horizontal incision, Thickness: 10 mm, height: 40 mm, Length: 1,800 mm T-base: approx. 40 mm wide	25 units = 45 m	901004	01
	Wall sealing strip 5 x 50 mm with self-adhesive base and integrated fleece backing colour: green	Ro 25 m	908158	01
	Compression fitting made of brass with euroconus 3/4" for pipe dimensions: 12 x 1.5 15 x 1.8	Bag 6 units Bag 10 units	421211 421500	01 01
	Connection coupling made of brass for pipe dimensions: 12 x 1.5 15 x 1.8	Bag 5 units Bag 10 units	401211 401500	01 01
Kits				
	top-Nopp® mini 12 kit 10 m² "top-Nopp® mini" castellated element for 12 mm pipe with fully adhesive backing 120 m KLIMAPEX® heating pipe PE-RT 12 x 1.5 mm 25 m wall sealing strips "mini", self-adhesive, 5 x 50 mm 6 units compression fitting MS 12 x 1.5 mm	1 set	089050	01
	top-Nopp® mini 15 kit 21 m² "top-Nopp® mini" castellated element for 15 mm pipe with fully adhesive backing 200 m KLIMAPEX® heating pipe PE-RT 15 x 1.8 mm 25 m wall sealing strips "mini", self-adhesive, 5 x 50 mm 10 units compression fitting MS 15 x 1.8 mm	1 set	089051	01

Exemplary overall structure

top-Nopp® mini 12:

Knauf N 430, gypsum-bound floor levelling filler

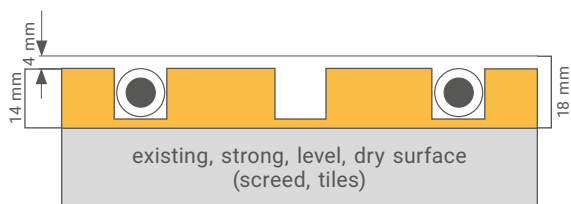

top-Nopp® mini 15:

Knauf N 430, gypsum-bound floor levelling filler

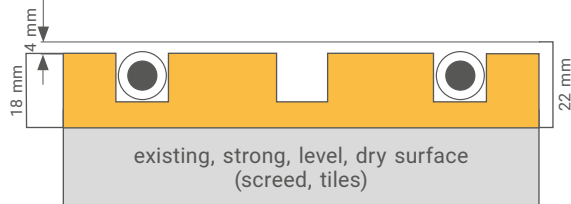

NOTE

The screed type, amount (observe minimum coverage) and quality of the levelling compound must be examined in each individual case according to the construction requirements (load, substrate and surface covering) as well as according to the manufacturer's specifications! In the case of all wooden substrates (OSB boards, etc.), please ask explicitly for the manufacturer's specifications regarding the grouting compound and primer, as higher coverage is usually needed here!

Underfloor heating systems for modernisation projects

4.3 Multibox-RTL individual room control

Multibox-RTL individual room control

for the renovation and subsequent installation of floor heating in individual rooms, e.g. Bath room. An GEG compliant control is possible thanks to the separate detection of the return flow temperature and the room temperature by the thermostat. A simple and inexpensive installation which increases comfort and reduces energy costs.

System illustration (example):

Multibox RTL ① in the system return flow of the floor heating ③ connected to return flow temperature in an existing heating system with heating surfaces ②.

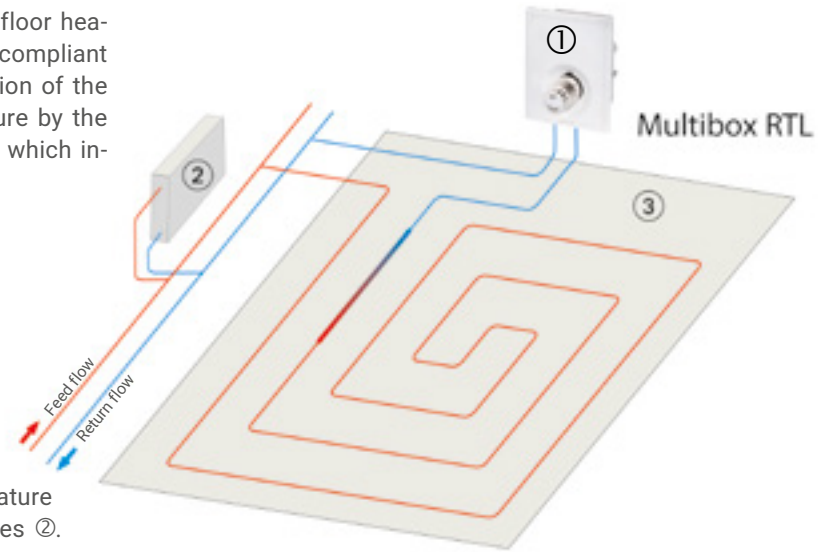

Item	Item description	PU	Item No.	PG
	FM control set for individual room control in accordance with GEG, consisting of base body with rotating connection block and connection thread 3/4" euroconus, bleed valve, EPS building protection panel Max. pipe length approx. 100 m pipe 17 x 2.0 mm or approx. 80 m pipe 15 x 1.8 mm or approx. 60 m pipe 12 x 1.5 mm in conjunction with configuration options 1 or 2			
	Option 1: consisting of: <ul style="list-style-type: none"> • 1 design thermostat head with integrated return flow temperature limitation • 1 white cover panel with rotating adjustment ring Dimensions FM box (BxHxT): 120 x 140 x 60 mm	1 set	573021	01
	Option 2: consisting of: <ul style="list-style-type: none"> • 1 adapter with return flow temperature limitation • 1 actuator • 1 cover for concealed assembly of the actuator Dimensions FM box (BxHxT): 150 x 200 x 60 mm	1 set	573031	01
	Order room thermostat optionally (see from page 71)			

NOTE Further connection components from page 30/31, controlling components and room thermostats from page 71.

Wall heating systems

5.1 Wall heating dry construction system





Wall heating dry construction system

EMPUR® gypsum plasterboards for heating and cooling are **designed for dry construction in new buildings or for renovations**, as they are easy and quick to install and allow **construction to progress rapidly**.

Our dry construction elements consist of a **12.5 mm thick gypsum plasterboard** into which the high-quality PE-RT 5-layer pipe is integrated at the factory. On the back, the elements are laminated with **30 mm EPS thermal insulation (WLS 035)**. The total panel thickness of 42.5 mm ensures sufficient **panel stability** with low weight. The position of the heating pipes is clearly printed on the surface of the panels to facilitate installation.

Two prefabricated panel sizes with one or two heating circuits allow flexible design of the wall surfaces. Another element, without a pipe circuit, can be used as a levelling/blind element. The elements can be processed with commercially available profiles (e.g. CD 60/27/06) like a standard plasterboard.

Item	Item description	PU	Item No.	PG
	Ceiling and wall element H/C 1,200 x 500 x 42.5 mm (0.6 m ²) made from 12.5 mm gypsum board and 30 mm EPS, WLS 035 ready for installation with PE-RT 8 x 1.0 mm pipe	1 unit	031006	01
	Ceiling and wall element H/C 2,000 x 1,200 x 42.5 mm (2.4 m ²) made from 12.5 mm gypsum board and 30 mm EPS, WLS 035 ready for installation with PE-RT 8 x 1.0 mm pipe	1 unit	031024	01
	Ceiling and wall compensation element 2,000 x 1,250 x 42.5 mm (2.5 m ²) made from 12.5 mm gypsum board and 30 mm EPS, WLS 035 ready-for-installation, without pipe (dummy element)	1 unit	031124	01

Further connection components for the system can be found on page 29.

NOTE

You will find the components for a wall heating system in dry construction in our OPTIMAL II system (see page 16f).





Wall heating systems

5.2 Vertical wall heating









Vertical wall heating as a wet system

The EMPUR® vertical wet wall heating system **consists of wall clip rails and high-quality KLIMAPEX® plastic heating pipes.** After the clip rails have been attached to the wall according to the laying plan, the heating pipe is clipped into them. When plastering the walls, a special **reinforcement** fabric prevents crack formation after drying in the case of gypsum plaster.

Item	Item description	PU	Item No.	PG
	Wall clip rail for pipe spacing in 50 mm grid Clip rail for pipe Ø 8 – 12 mm, length 2 m with adhesive strips	1 unit	911202	01
	Wall clip rail for pipe spacing in 25 mm grid Clip rail for pipe Ø 15 mm, length 2 m with adhesive strips	1 unit	911502	01
 	KLIMAPEX® heating pipe PE-RT as a 5-layer pipe Pipe made of polyethylene, Type I/II in accordance with DIN EN ISO 22391-2 and DIN 16833, with increased thermal stability and insoluble diffusion-tight EVOH barrier layer in accordance with DIN 4726, Base material: PE-MD with increased thermal stability		 3V 204 PE-RT	
	Application classes: 4: Underfloor heating, low-temperature heating, radiator connection system 5: High-temperature heating, radiator connection system High loading capacity: continuous operating temperature +70 °C, short-term excess temperature (max. two years) +90°C, operating pressure 4 bar 10-year material and consequential damage liability			
	Dimension	Internal Ø	Weight approx. 25 kg	
	PE-RT 12 x 1.5	9.0		Ro 120 m 111231 01
	PE-RT 15 x 1.8	11.4	pipe, green	Ro 200 m 111532 01

Wall heating systems

5.2 Vertical wall heating

Item	Item description	PU	Item No.	PG
	Dowel nail Borehole Ø 6 mm x 50 mm, requirement 4 units/running metre of rail	Bag 100 units	900050	01
	Dowel clamp Borehole Ø 6 mm	Bag 20 units	900051	01
	Compression fitting made of brass with euroconus 3/4" for pipe dimensions: 12 x 1.5	Bag 6 units	421211	01
	15 x 1.8	Bag 10 units	421500	01
	Connection coupling made of brass for pipe dimensions: 12 x 1.5	Bag 5 units	401211	01
	15 x 1.8	Bag 10 units	401500	01
	Glass reinforcement fabric Reinforcement fabric for stucco, 6 mm mesh width 1 m x 25 m roll	Ro 25 m ²	900053	01
	Angle brace 90°, open made of plastic, for redirecting manifold connections, for pipes up to max. Ø 14 mm	Bag 10 units	901014	01
	for pipes up to max. Ø 17 mm	Bag 10 units	901418	01
	12 m² wall heating kit for RA10 pipe 12 x 1.5 Consisting of: 120 m KLIMAPEX® heating pipe PE-RT 12 x 1.5 12 units 2 m clip rails 6 units 12 x 1.5 compression fittings 40 units dowel clamps 100 units dowel nails Full kit packed in 1 carton, clips rails enclosed loose	1 set	900058	01
	20 m² wall heating kit for RA10 pipe 15 x 1.8 Consisting of: 200 m KLIMAPEX® heating pipe PE-RT 15 x 1.8 20 units 2 m clip rails 10 units 15 x 1.8 compression fittings 60 units dowel clamps 200 units dowel nails Full kit packed in 1 carton, clips rails enclosed loose	1 set	900059	01
PLANNING NOTE Consumption/planned quantity when installing above kits: 2 m clip rail/m ² wall surface (install rail at 0.5 m intervals). 1 m clip rail/5 m tube (Individual deviations are possible depending on the structural conditions!)				

NOTE

The components for a wall heating system in dry construction can be found on page 25.



Ceiling heating/cooling for new buildings/modernisation

6.1 Ceiling/wall elements and accessories









Heating and cooling elements for ceiling and wall

In buildings with increasingly better thermal insulation and a large proportion of glass surfaces, unwelcome increases in internal temperatures can occur on sunny days. It is recommended to use ceiling and wall elements for heating and cooling purposes to create **a comfortable indoor climate, especially in the summer months. The systems can be used individually or together with a surface heating/temperature control system.** The combination with heat pump systems enables efficient temperature control of individual rooms or entire buildings.

Item	Item description	PU	Item No.	PG
	Ceiling element H/C aluminium Surface lacquered white, similar to RAL 9003 600 x 600 x 30 mm (0.36 m ²), WLS 035 ready for installation with PE-RT 8 x 1.0 mm pipe (Requirement: 2.778 pcs/m ²)	6 units = 2.16 m ²	031004	01
	Ceiling compensation element Surface lacquered white, similar to RAL 9003 600 x 600 x 30 mm (0.36 m ²), WLS 035 ready-for-installation, without pipe (dummy element) (Requirement: 2.778 pcs/m ²)	6 units = 2.16 m ²	031005	01

Ceiling heating/cooling for new buildings/modernisation

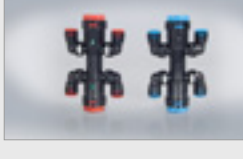
6.1 Ceiling/wall elements and accessories

Item	Item description	PU	Item No.	PG
	Ceiling and wall element H/C 1,200 x 500 x 42.5 mm (0.6 m ²) made from 12.5 mm gypsum board and 30 mm EPS, WLS 035 ready for installation with PE-RT 8 x 1.0 mm pipe (Requirement: 1.667 pcs/m ²)	1 unit	031006	01
	Ceiling and wall element H/C 2,000 x 1,200 x 42.5 mm (2.4 m ²) made from 12.5 mm gypsum board and 30 mm EPS, WLS 035 ready for installation with PE-RT 8 x 1.0 mm pipe (Requirement: 0.416 pcs/m ²)	1 unit	031024	01
	Ceiling and wall compensation element 2,000 x 1,250 x 42.5 mm (2.5 m ²) made from 12.5 mm gypsum board and 30 mm EPS, WLS 035 ready-for-installation, without pipe (dummy element) (Requirement: 0.4 pcs/m ²)	1 unit	031124	01
	Plug for push fitting 8 mm, plastic, black	1 unit	031208	01
	20 mm, plastic, black	1 unit	031220	01
	Push fitting H/C element* for connecting line aluminium composite pipe 20 x 2.0 mm Through fitting 20 x 2.0 mm with 2 outlets, 8 x 1.0 mm (red)	1 unit	031182	01
	Through fitting 20 x 2.0 mm with 2 outlets, 8 x 1.0 mm (blue)	1 unit	032182	01
	for connecting line PE pipe 20 x 2.0 mm Through fitting 20 x 2.0 mm with 2 outlets, 8 x 1.0 mm (red)	1 unit	031282	01
	Through fitting 20 x 2.0 mm with 2 outlets, 8 x 1.0 mm (blue)	1 unit	032282	01
	Push fitting H/C element* for connecting line aluminium composite pipe 20 x 2.0 mm Through fitting 20 x 2.0 mm with 4 outlets, 8 x 1.0 mm (red)	1 unit	031184	01
	Through fitting 20 x 2.0 mm with 4 outlets, 8 x 1.0 mm (blue)	1 unit	032184	01
	for connecting line PE pipe 20 x 2.0 mm Through fitting 20 x 2.0 mm with 4 outlets, 8 x 1.0 mm (red)	1 unit	031284	01
	Through fitting 20 x 2.0 mm with 4 outlets, 8 x 1.0 mm (blue)	1 unit	032284	01
	Push fitting H/C element* Coupling 20 x 2.0 mm for aluminium composite pipe	1 unit	032122	01
	Coupling 20 x 2.0 mm for PE pipe	1 unit	032222	01
	Coupling 8 x 1.0 mm for PE-RT pipe	1 unit	032288	01

* On-site connection via wholesaler

Take the tolerance dimensions of the fittings into account when selecting the pipe (see data sheet).

NOTE





You will find control components for heating/cooling from page 73 onwards. It is recommended to monitor the dew point. Humidity monitors (see page 81) can be used for this purpose.

Accessories and tools

7.1 Panel heating system accessories







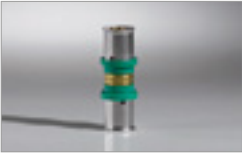

Panel heating system accessories

Item	Item description	PU	Item No.	PG
	Compression fittings made of brass with euroconus 3/4" for pipe dimensions:			
	10 x 1.3	Bag 6 units	421000	01
	12 x 1.5	Bag 6 units	421211	01
	15 x 1.8	Bag 10 units	421500	01
	17 x 2.0	Bag 10 units	421700	01
	20 x 2.0	Bag 10 units	422000	01
	Compression fittings for stainless steel manifolds made of nickel-plated brass with euroconus 3/4" for pipe dimensions:			
	14 x 2.0 (for aluminium composite pipe)	Bag 10 units	621400	01
	15 x 1.8	Bag 10 units	421501	01
	16 x 2.0 (for aluminium composite pipe)	Bag 10 units	621600	01
	17 x 2.0	Bag 10 units	421701	01
	20 x 2.0	Bag 10 units	422001	01
	Connection couplings made of brass for pipe dimensions:			
	10 x 1.3	Bag 5 units	401010	01
	12 x 1.5	Bag 5 units	401211	01
	15 x 1.8	Bag 10 units	401500	01
	16 x 2.0	Bag 10 units	401600	01
	17 x 2.0	Bag 10 units	401700	01
	20 x 2.0	Bag 10 units	402000	01
	25 x 2.3	Bag 5 units	402500	01
	Sealing cap for not required manifold outlets			
	3/4" IT brass with euroconus and seals	1 unit	790111	01
	3/4" IT nickel-plated brass with euroconus and seals	1 unit	790112	01









Accessories and tools

7.1 Panel heating system accessories

Item	Item description	PU	Item No.	PG
	Press-fit coupling with TH contour for pipe dimensions:			
	14 x 2.0	Bag 5 Stk	301400	01
	15 x 1.8	Bag 5 Stk	301500	01
	16 x 2.0	Bag 5 Stk	301600	01
	17 x 2.0	Bag 5 Stk	301700	01
	20 x 2.0	Bag 5 Stk	302000	01
	25 x 2.3	Bag 5 Stk	302500	01
	Adapter nipple with TH contour			
	with pipe thread and press-fit connection for pipe dimensions:			
	15 x 1.8 x 1/2" ET	Bag 10 units	361500	01
	16 x 2.0 x 1/2" ET	Bag 10 units	361600	01
	17 x 2.0 x 1/2" ET	Bag 10 units	361700	01
	20 x 2.0 x 3/4" ET	Bag 10 units	362000	01
25 x 2.3 x 3/4" ET	Bag 5 units	362500	01	
	Adapter sleeve with TH contour			
	15 x 1.8 x 1/2" IT	Bag 10 units	351500	01
	Connection screws			
	for pipe dimensions:			
	1/2" ET x 14 x 2.0	Bag 10 units	461400	01
	1/2" ET x 15 x 1.8	Bag 10 units	461500	01
	1/2" ET x 17 x 2.0	Bag 10 units	461700	01
	1/2" ET x 20 x 2.0	Bag 10 units	462000	01
	3/4" ET x 25 x 2.3	Bag 5 units	462500	01
3/4" IT x 25 x 2.3	Bag 5 units	452500	01	
	Double nipple			
	made of brass with euroconus			
	3/4" ET	Bag 5 units	793435	01
	1" ET	Bag 5 units	793440	01
	Radiator connection bracket 90°			
	300 mm long, nickel-plated with press-fit connection			
	Dimensions 15 x 1.8 x 300 mm	Bag 2 units	371503	01
	Dimensions 17 x 2.0 x 300 mm	Bag 2 units	371703	01
	ATTENTION: PU 2 units in bag, price per unit			
	Radiator T-connection-piece			
	300 mm long, nickel-plated with press-fit connection			
	Dimensions 15 x 1.8 x 15 x 1.8 x 300 mm	Bag 2 units	371513	01
	Dimensions 17 x 2.0 x 17 x 2.0 x 300 mm	Bag 2 units	371713	01
	ATTENTION: PU 2 units in bag, price per unit			











Accessories and tools

7.1 Panel heating system accessories

Item	Item description	PU	Item No.	PG	
	Long staples for PUR-THERM® stapler system for pipes up to Ø 20 mm, green, 50-unit magazines	Car = 1.000 units	911001	01	
	Short staples PUR-THERM® stapler system, for pipes up to Ø 20 mm, black, 50-unit magazines	Car = 1.000 units	911000	01	
	Expansion gap section in accordance with DIN 18560, made of PE/PET 100/10 mm black, with levelling base and adhesive strips and horizontal incision; Length: 1,800 mm	10 units = 18 m	901010	01	
	Edge insulation strip with adhesive film tab, green for the standardised separation of floating screeds with underfloor heating on walls and rising structures in accordance with DIN EN 1264-4/DIN 18560-2, made of closed-cell PE foam with patented tear-off edge and welded film tab with adhesive for fixing and sealing to the surface	8 x 150 mm 10 x 150 mm	Ro 50 m Ro 50 m	908152 908154	01 01
	Edge insulation strip with self-adhesive base, green Description as above but with additional adhesive fixing on the foam backing for mounting to dry, smooth, level rising structures (e.g. plasterboard)	8 x 150 mm	Ro 50 m	908159	01
	PE film moisture barrier in accordance with DIN 18533/W1-E for structural waterproofing on the foundation slab against rising dampness, made of tear-proof PE film with PE foam underneath and integrated sealing tape for single-sided overlapping, width 1,250 mm + overlap	Ro 50 m ²	903200	01	
	Important: Request the EMPUR® installation guidelines before installation!				
	Bitumen sealant and adhesive Cartridge with polymer bitumen adhesive, 300 ml Ø consumption: 2 cartridges/50 m ²	1 unit	903201	01	
	Fixing tape, single-sided adhesive 100 mm wide, for PE film as a moisture barrier, for adhering connections	Ro 5 m	903204	01	
	Butyl sealing tape as an alternative to bitumen sealant and adhesive For adhering PE film as a moisture barrier, 20 mm wide, 15 m long, Ø consumption: 1 roll/50 m ²	Ro 15 m	903202	01	







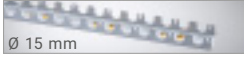

Accessories and tools

7.1 Panel heating system accessories









Item	Item description	PU	Item No.	PG
	System connection strips For producing connections on rising masonry walls and for waterproofing, width 200 mm, length 25 m	Ro 25 m	903203	01
	PE cover sheeting, as a separating layer Width 2 m, length 50 m, thickness 0.1 mm	Ro 100 m ²	900020	01
	Plastic grid film (PP) with printed 100 x 100 mm grid Length: 100 m, width 1,030 mm	Ro 103 m ²	901002	01
	Plastic adhesive tape (extremely tear-proof) highly adhesive, for sealing intersections, 1 roll for approx. 50 m ² , roll 66 m, width 50 mm, core diameter 75 mm, grey/silver	Car 36 Ro	905501	01
	Film dowel for attaching the grid film to the insulation, Requirement = 4 units/m ² , shaft length 25 mm	Bag 100 units	900015	01
	Retaining dowel made of PE, 80 mm shaft length, Ø 8 mm borehole	Bag 100 units	900010	01
	Deflection curve 90° for deflecting heating pipes in the manifold, for pipes up to max. Ø 20 mm, r = 130 mm	Bag 10 units	912800	01
	Angle brace 90°, open for redirecting pipes in the manifold and floor area for pipes up to max. Ø 14 mm for pipes up to max. Ø 17 mm for pipes up to max. Ø 20 mm	Bag 10 units Bag 10 units Bag 10 units	901014 901418 902020	01 01 01
	Expansion joint protective pipe for pipes up to Ø 18 mm, length 400 mm, slotted	Bag 10 units	918400	01
	for pipes up to Ø 18 mm, length 25 m, unslotted for pipes up to Ø 18 mm, length 25 m, slotted	1 Ro 1 Ro	918500 918600	01 01

Accessories and tools

7.1 Panel heating system accessories





Item	Item description	PU	Item No.	PG
	Clip rail (2 m long with adhesive strips)			
Ø 8-12 mm	for pipe Ø 8–12 mm, for pipe spacing in 50 mm grid	1 unit	911202	01
	for pipe Ø 15mm, for pipe spacing in 25 mm grid	1 unit	911502	01
Ø 15 mm	for pipe Ø 16mm, for pipe spacing in 50 mm grid	1 unit	911602	01
	for pipe Ø 17mm, for pipe spacing in 50 mm grid	1 unit	911702	01
Ø 16 mm				
				
Ø 17 mm				
	Marking set for indicating a moisture measuring point of a heating screed in accordance with DIN 1264 Part 4 (min. 3 measurement points/200 m ²)	Bag 5 units	990100	01
	Hard bed according to DIN EN 18560-2 made of hemp chips with solvent-free bitumen film for "bonding" the components. For filling flaws in the insulation around line and pipe routes. Density approx. 150 kg/m ³ , delivery in 100l bag, weight: 15 kg Observe processing instructions and application range!	1 Bag	904000	01
	<i>The filling has been tested by the "Sentinel Haus Institut" according to the AgBB scheme, is demonstrably low in emissions and can therefore be used indoors without any concerns.</i>			
	Hard bed, inorganic consisting of vermiculite granulation (100% mineral) coated with a special bitumen layer, glued and cemented when installed, meets the requirements of DIN EN 18560-2, for filling the insulation voids in the area of pipe and conduit routes. Bulk density approx. 145 kg/m ³ , delivery in 100 l sack, weight: 14.5 kg Observe processing instructions and application range!	1 Bag	904001	01
NEW				
	Screed reinforcement fibre PP plastic fibre for preventing stress and shrinkage cracks, especially for screeds with ceramic top layers, Requirement: Five bags fibre/cubic metre of screed = 15 m ² for 65 mm screed thickness (1 bag/50 kg cement) in biodegradable bags	1 Bag	902000	01
	Screed additive Plasticiser for cement screeds in accordance with DIN 18560 Requirement approx. 0.2 kg/m ² per 65 mm screed thickness Observe processing instructions and application range!	10 kg	901000	01

Panel heating system tools

Item	Item description	PU	Item No.	PG
	PUR-THERM® stapler system Precise, low-wear tool for handling magazine-loaded staples, with curved magazine and ergonomic grip Total height approx. 82 cm (handle above staple surface)	1 unit	991010	02
	PUR-THERM® stapler system extension for ergonomic adjustment of the working height, consisting of extension of approx. 10 cm and two screws	1 unit	991011	02
	PUR-THERM® pipe dispenser (without pipe) Consisting of a plastic drum with removable side parts and a metal load-bearing roller frame for pipe rolls with core Ø 260 mm, width 420 mm	1 unit	990800	02
	Hand dispenser robust design for plastic adhesive tape core diameter 75 mm	1 unit	995501	02
	Pipe cutter for pipes up to Ø 35 mm	1 unit	910027	02
	Trestle 1 set = 2 units for 600 m/400 m disposable drums 2 units per drum required	1 set	992750	02
	Press jaw with TH press contour for standard press machines			
	for pipe Ø 14 x 2.0	1 unit	961014	02
	for pipe Ø 15 x 1.8	1 unit	961015	02
	for pipe Ø 16 x 2.0	1 unit	961016	02
	for pipe Ø 17 x 2.0	1 unit	961017	02
	for pipe Ø 20 x 2.0	1 unit	961020	02
	for pipe Ø 25 x 2.3	1 unit	961025	02
	Calibrator with standard handle for calibrating the KLIMAPEX® pipe			
	for pipe Ø 15 x 1.8	1 unit	961501	02
	for pipe Ø 16 x 2.0	1 unit	961601	02
	for pipe Ø 17 x 2.0	1 unit	961701	02
	for pipe Ø 20 x 2.0	1 unit	962001	02
	for pipe Ø 25 x 2.3	1 unit	962501	02

Accessories and tools

7.2 Panel heating system tools

Item	Item description	PU	Item No.	PG
	Herz Changefix Tool Changefix Tool for upper part of thermostat valves, with threaded connection 28 x 1.5 (Herz), for repairing systems without changing water, with little time and cost	1 unit	961720	02
	Notching pliers Special pliers for notching pipe feed-through holes in the expansion joint section	1 unit	901011	02
	Door tensioner with rotating bezel, open, extending length min. 570 mm to max. 960 mm	1 unit	990200	02
	Ceiling tensioner with rotating bezel, open, adjustable from min. 1,650 mm to max. 2,800 mm	1 unit	990210	02



Stainless steel manifold, series 03 Balance

pre-mounted with integrated valve for dynamic flow control, without manifold connection set

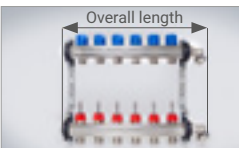
Item	Item description	Heating circuit	Connection	Overall length	Item No.	PG
	System manifold HCM-D Balance* with integrated, dynamically control valves in the pressure range 17-60 kPa, pre-settable for flow rates of 30-300 l/h Complete manifold made of 1" stainless steel section pipe, 50 mm valve clearance. Factory assembled on the manifold holder with inserts for noise suppression, pre-mounted for quick installation in the manifold cabinet, return flow valve (above) with blue protection cap, EMPUR® actuators are pre-assembled instead of the blue protection cap, feed flow (below) with flow indicator without scaling for shut off and function display. Heating circuit connections 3/4" euroconus, two manifold end-pieces with reducer revolving for filling, bleeding and draining, rotating, packed in bag, all packed in carton with identification plates..	HCM-DB 2	1" IG	200	220278	01
	HCM-DB 3	1" IG	250	220378	01	
	HCM-DB 4	1" IG	300	220478	01	
	HCM-DB 5	1" IG	350	220578	01	
	HCM-DB 6	1" IG	400	220678	01	
	HCM-DB 7	1" IG	450	220778	01	
	HCM-DB 8	1" IG	500	220878	01	
	HCM-DB 9	1" IG	550	220978	01	
	HCM-DB 10	1" IG	600	221078	01	
	HCM-DB 11	1" IG	650	221178	01	
	HCM-DB 12	1" IG	700	221278	01	

Compression fittings according to the pipe dimension see page 30, allocation table see page 39, manifold cabinets see page 47 et seq. Manifold accessories, connection/WMZ sets see page 42.

Item	Item description	PU	Item No.	PG
	Extension set for system manifolds HCM-D Balance made of 1" section pipe, nickel-plated with integrated, dynamic control valves, heating circuit connections 3/4" euroconus Set consisting of: 1x backflow valve (top), 1 flow extension with FR without scaling for shut-off and function display, 2 x 1" double nipples with self-sealing O-rings, for easy assembly and secure manifold connection, packed loose in carton, for assembly on the right/left of the manifold	1 set	220178	01

NOTE

The water quality requirements according to VDI 2035 must be adhered to!

* 5 years system warranty with exclusive use of EMPUR® components:

Manifolds, actuators, room operating units and control terminal strips

Manifold technology

8.1 Stainless steel manifold

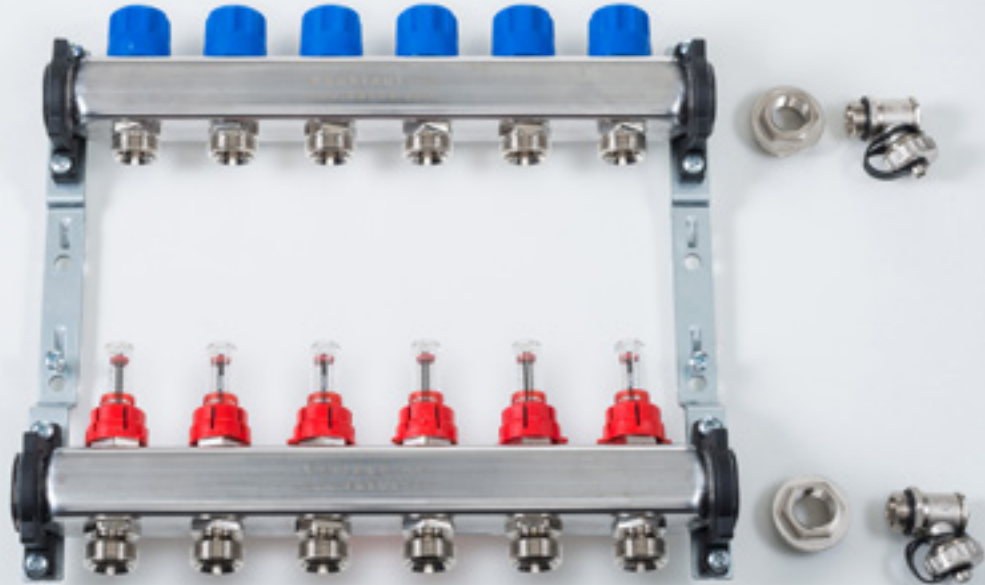

Stainless steel manifold, series 03

pre-mounted on manifold holder without manifold connection kit

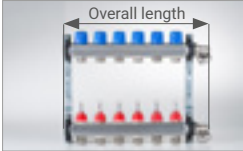
Item	Item description	Heating circuit	Connec- tion	Overall length	Item No.	PG
	System manifold HCM-D* pre-mounted on manifold holder, with flow rate indicators					
	Complete manifold made of 1" stainless steel section pipe, 50 mm valve clearance. Factory assembled on the manifold holder with inserts for noise suppression, preassembled for quick installation in the manifold cabinet, return flow valve (above) with blue protection cap, EMPUR® actuators are pre-assembled instead of the blue protection cap, feed flow (below) with controllable and adjustable flow rate indicators (0-2.5 l/min.), heating circuit connections 3/4" euroconus, two manifold end-pieces with reducer revolving for filling, bleeding and draining, rotating, packed in bag, all packed in carton with identification plates.	HCM-D 2	1" IG	200	220276	01
		HCM-D 3	1" IG	250	220376	01
		HCM-D 4	1" IG	300	220476	01
		HCM-D 5	1" IG	350	220576	01
		HCM-D 6	1" IG	400	220676	01
		HCM-D 7	1" IG	450	220776	01
		HCM-D 8	1" IG	500	220876	01
		HCM-D 9	1" IG	550	220976	01
		HCM-D 10	1" IG	600	221076	01
		HCM-D 11	1" IG	650	221176	01
		HCM-D 12	1" IG	700	221276	01

Compression fittings according to the pipe dimension see page 30, allocation table see page 39, manifold cabinets see page 47 et seq. Manifold accessories, connection/WMZ sets see page 42.

Item	Item description	PU	Item No.	PG
	Extension set for system manifolds HCM-D made of 1" section pipe, nickel-plated with integrated valves, 50 mm valve clearance, heating circuit connections 3/4" euroconus			
	Set consisting of: 1x backflow valve (top) with blue protection cap, EMPUR® actuator can be mounted directly instead, 1x flow extension (bottom) with controllable and adjustable flow rate indicators (0-2.5 l/min), 2 x 1" double nipples with self-sealing O-rings, for easy assembly and secure manifold connection, packed loose in carton, for assembly on the right/left of the manifold	1 set	220176	01

NOTE The water quality requirements according to VDI 2035 must be adhered to!
* 5 years system warranty with exclusive use of EMPUR® components:
Manifolds, actuators, room operating units and control terminal strips

Assignment of **stainless steel manifolds** / manifold connection set and WMZ connection set in combination with **manifold cabinets "Top Standard" and "Exclusiv"**

The following combinations are possible and should be ordered separately as a set:

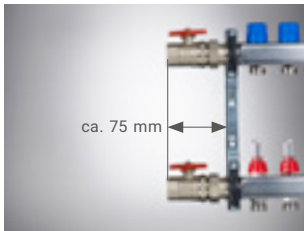

Ball valve set passageway
(Item No. 295100)

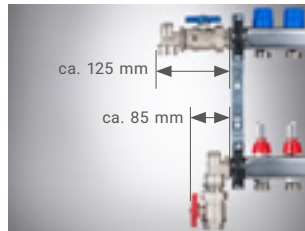

Manifold connection set 90°
(Item No. 291100)

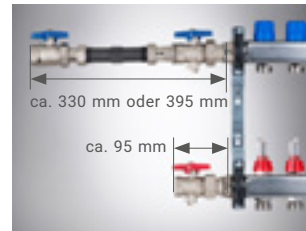

WMZ connection set
passageway (Item No. 721017
or 721027)

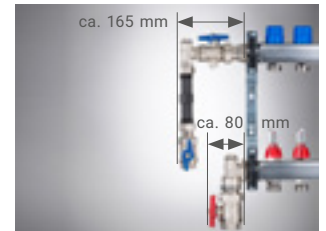

WMZ connection set 90°
(Item No. 721037 or 721047)

Heating circuits	Ball valve set passageway 295100	Manifold connection set 90° 291100	WMZ connection set passageway 721017	WMZ connection set passageway 721027	WMZ connection set 90° 721037 / 721047
2	520 mm	520 mm	720 mm	720 mm	520 mm
3	520 mm	520 mm	720 mm	720 mm	520 mm
4	520 mm	520 mm	720 mm	920 mm	720 mm
5	520 mm	720 mm	920 mm	920 mm	720 mm
6	720 mm	720 mm	920 mm	920 mm	720 mm
7	720 mm	720 mm	920 mm	920 mm	720 mm
8	720 mm	720 mm	920 mm	1,120 mm	920 mm
9	720 mm	920 mm	1,120 mm	1,120 mm	920 mm
10	920 mm	920 mm	1,120 mm	1,120 mm	920 mm
11	920 mm	920 mm	1,120 mm	1,120 mm	920 mm
12	920 mm	920 mm	1,120 mm	---	1,120 mm

Assignment of **stainless steel manifolds** / manifold connection set and WMZ connection set in combination with **manifold cabinets "Economy" flush- or surface mounted**

Heating circuits	Ball valve set passageway 295100	Manifold connection set 90° 291100	WMZ connection set passageway 721017	WMZ connection set passageway 721027	WMZ connection set 90° 721037 / 721047
2	550 mm	550 mm	700 mm	700 mm	550 mm
3	550 mm	550 mm	700 mm	850 mm	550 mm
4	550 mm	550 mm	850 mm	850 mm	550 mm
5	550 mm	550 mm	850 mm	850 mm	700 mm
6	550 mm	700 mm	850 mm	1,000 mm	700 mm
7	700 mm	700 mm	1,000 mm	1,000 mm	700 mm
8	700 mm	700 mm	1,000 mm	1,000 mm	850 mm
9	700 mm	850 mm	1,000 mm	---	850 mm
10	850 mm	850 mm	---	---	850 mm
11	850 mm	850 mm	---	---	1,000 mm
12	850 mm	1,000 mm	---	---	1,000 mm

NOTE

The images show possible installation situations.

Other combinations with valves (page 43) and the assignment of manifold – manifold cabinet (from page 47) are possible, however, but not available as a set.

Manifold technology

8.2 Brass manifold

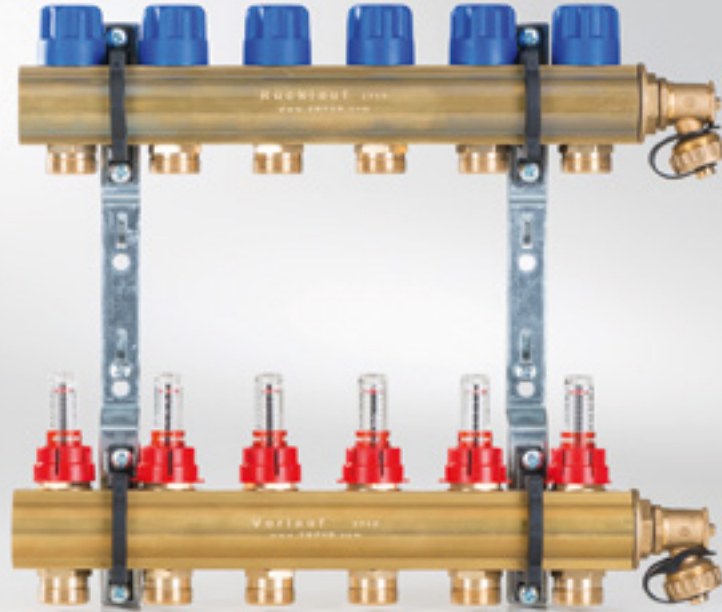

Brass manifold, version 2.0

pre-mounted on manifold holder without manifold connection kit

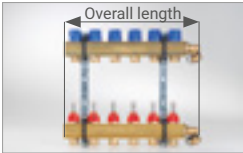
Item	Item description	Heating circuit	Connection	Overall length	Item No.	PG
	System manifold HCM-D* with flow rate indicators	HCM-D 2	1" IG	150	220246	01
	<p>Complete manifold made of brass section pipe with integrated valves, 50 mm valve clearance, return valves (above) with blue protection cap, factory assembled on manifold holders with inserts for noise suppression. EMPUR® actuators are pre-assembled instead of the blue protection cap, feed flow (bottom) with controllable and adjustable flow rate indicators (0-2.5 l/min.). Heating circuit connection 3/4" ET eurocones. Two manifold endpieces with reducer for filling, bleeding and draining, rotating, packed in bag and enclosed. All packaged in a carton and with identification plates.</p>	HCM-D 3	1" IG	200	220346	01
		HCM-D 4	1" IG	250	220446	01
		HCM-D 5	1" IG	300	220546	01
		HCM-D 6	1" IG	350	220646	01
		HCM-D 7	1" IG	400	220746	01
		HCM-D 8	1" IG	450	220846	01
		HCM-D 9	1" IG	500	220946	01
		HCM-D 10	1" IG	550	221046	01
		HCM-D 11	1" IG	600	221146	01
		HCM-D 12	1" IG	650	221246	01
		HCM-D 13	1" IG	700	221341	01
		HCM-D 14	1" IG	750	221441	01
		HCM-D 15	1" IG	800	221541	01
		HCM-D 16	1" IG	850	221641	01

Compression fittings according to the pipe dimension see page 30, allocation table see page 39, manifold cabinets see page 47 et seq. Manifold accessories, connection/WMZ sets see page 42.

Item	Item description	PU	Item No.	PG
	<p>Extension set for system manifolds HCM-D made of 1" brass section pipe with integrated valve, heating circuit connections 3/4" euroconus</p> <p>Set consisting of: 1x backflow valve (top) with blue protection cap, EMPUR® actuator can be mounted directly instead, 1x flow extension (bottom) with controllable and adjustable flow rate indicators (0-2.5 l/min), 2 x 1" double nipples with self-sealing O-rings, for easy assembly and secure manifold connection, packed loose in carton, for assembly on the right/left of the manifold</p>	1 set	220141	01

Assignment of **brass manifolds** / manifold connection set and WMZ connection set

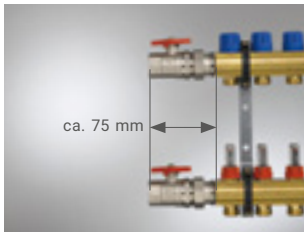

Ball valve set passageway
(Item No. 295100)

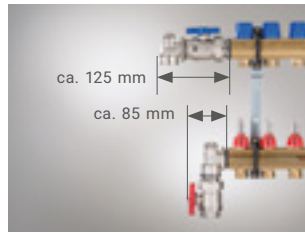

Manifold connection set 90°
(Item No. 291100)

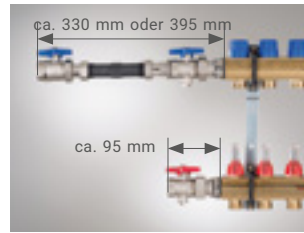

WMZ connection set
passageway (Item No. 721017
or 721027)

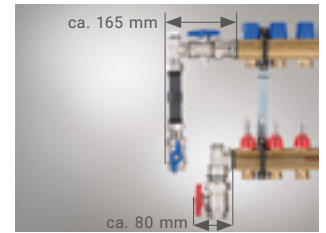

WMZ connection set 90°
(Item No. 721037 or 721047)

in combination with manifold cabinets "Top Standard" and "Exclusiv" / "plus"

Heating circuits	Ball valve set passageway 295100 (size)	Manifold connection set 90° 291100 (size)	WMZ connection set passageway 721017 (size)	721027 (size)	WMZ connection set 90° 721037 / 721047 (size)
2-4	520 mm (1)	520 mm (1)	720 mm (2)	720 mm (2)	520 mm (1)
5	520 mm (1)	520 mm (1)	720 mm (2)	920 mm (3)	720 mm (2)
6	520 mm (1)	720 mm (2)	920 mm (3)	920 mm (3)	720 mm (2)
7-8	720 mm (2)	720 mm (2)	920 mm (3)	920 mm (3)	720 mm (2)
9	720 mm (2)	720 mm (2)	920 mm (3)	1,120 mm (4)	920 mm (3)
10	720 mm (2)	920 mm (3)	1,120 mm (4)	1,120 mm (4)	920 mm (3)
11-12	920 mm (3)	920 mm (3)	1,120 mm (4)	1,120 mm (4)	920 mm (3)
13	920 mm (3)	920 mm (3)	1,120 mm (4)	1,320 mm (4+)	1,120 mm (4)
14	920 mm (3)	1,120 mm (4)	1,320 mm (4+)	1,320 mm (4+)	1,120 mm (4)
15-16	1,120 mm (4)	1,120 mm (4)	1,320 mm (4+)	1,320 mm (4+)	1,120 mm (4)

in combination with manifold cabinets "Economy" flush- or surface mounted

Heating circuits	Ball valve set passageway 295100 (size)	Manifold connection set 90° 291100 (size)	WMZ connection set passageway 721017 (size)	721027 (size)	WMZ connection set 90° 721037 / 721047 (size)
2-3	550 mm (1)	550 mm (1)	700 mm (2)	700 mm (2)	550 mm (1)
4	550 mm (1)	550 mm (1)	700 mm (2)	850 mm (3)	550 mm (1)
5	550 mm (1)	550 mm (1)	850 mm (3)	850 mm (3)	550 mm (1)
6	550 mm (1)	550 mm (1)	850 mm (3)	850 mm (3)	700 mm (2)
7	550 mm (1)	700 mm (2)	850 mm (3)	1,000 mm (4)	700 mm (2)
8	700 mm (2)	700 mm (2)	1,000 mm (4)	1,000 mm (4)	700 mm (2)
9	700 mm (2)	700 mm (2)	1,000 mm (4)	1,000 mm (4)	850 mm (3)
10	700 mm (2)	850 mm (3)	1,000 mm (4)	---	850 mm (3)
11	850 mm (3)	850 mm (3)	---	---	850 mm (3)
12	850 mm (3)	850 mm (3)	---	---	1,000 mm (4)
13	850 mm (3)	1,000 mm (4)	---	---	1,000 mm (4)
14	1,000 mm (4)	1,000 mm (4)	---	---	1,000 mm (4)
15	1,000 mm (4)	1,000 mm (4)	---	---	---
16	1,000 mm (4)	---	---	---	---

NOTE







* 5 years system warranty with exclusive use of EMPUR® components:

Manifolds, actuators, room operating units and control terminal strips

The images show possible installation situations. These combinations should be ordered separately as a set. Other combinations with valves (page 43) and the assignment of manifold – manifold cabinet (from page 47) are possible, however, but not available as a set.









Manifold technology

8.3 Manifold accessories for stainless steel and brass manifolds

Item	Item description	PU	Item No.	PG
	Manifold connection set 90° for manifold 1" consisting of: 2 ball valves passageway 1" with screwed connection and connection bracket, 1" IT/ET, O-ring seal, additional borehole 1/2" for sensor or thermometer	1 set	291100	01
	Manifold connection set passageway for manifold 1" or 5/4" nickel-plated, O-ring seal, consisting of: 2 ball valves with screwed connection 1" IT/ET 5/4" IT/ET	1 set 1 set	295100 290114	01 01
	1/2" WMZ connection set 90°, fully pre-assembled for manifold 1", incl. ball valves for installed length L = 110 mm (Qn = 0.6–1.5 m³/h) consisting of: 1 ball valve passageway, 2 elbows and 2 ball valves passageway with M10x1 sensor borehole for short direct immersion sensor, type DS (27.5) in accordance with EN1434, total length approx. 315 mm, installation width approx. 165 mm	1 set	721037	01
	3/4" WMZ connection set 90°, fully pre-assembled for manifold 1", incl. ball valves for installed length L = 130 mm (Qn = 1.6–2.5 m³/h) consisting of: 1 ball valve passageway, 2 elbows and 2 ball valves passageway with M10x1 sensor borehole for short direct immersion sensor, type DS (27.5) in accordance with EN1434, total length approx. 385 mm, installation width approx. 165 mm	1 set	721047	01
	1/2" WMZ connection set passageway, fully pre-assembled for manifold 1", incl. ball valves for installed length L = 110 mm (Qn = 0.6–1.5 m³/h) consisting of: 1 ball valve passageway and 2 ball valves passageway with M10x1 sensor borehole for short direct immersion sensor, type DS (27.5) in accordance with EN1434, Total length approx. 330mm	1 set	721017	01
	3/4" WMZ connection set passageway, fully pre-assembled for manifold 1", incl. ball valves for installed length L = 130 mm (Qn = 1.6–2.5 m³/h) consisting of: 1 ball valve passageway and 2 ball valves passageway with M10x1 sensor borehole for short direct immersion sensor, type DS (27.5) in accordance with EN1434, Total length approx. 395 mm	1 set	721027	01
	Ball valve 3/4" nickel-plated for manifold 1" according to DIN EN 1264-4 every circuit must have two shut-off valves, for assembly on feed flow (bottom)	1 unit	722002	01
	Brass flow meter for manifold 1" Flow meters with direct display 0.6-2.4 l/min. 3/4" x 3/4" IT x 3/4" ET euroconus, for installation in the return flow (above)	1 unit	233434	01

NOTE Assignment of manifold and connection sets see page 39 and 41

8.3 Manifold accessories for stainless steel and brass manifolds

Item	Item description	PU	Item No.	PG
	Balancing valve 2-16 l/min with angle seat valve and integrated flow indicator for the precise and fast hydraulic balancing of consumer circuits in HVAC systems, max. operating temperature 100 °C at 6 bar operating pressure or 70 °C at 10 bar. Brass casing, EPDM seals. DN 20, kvs value 2.0; installation length approx. 86 mm, total length approx. 101 mm	1 unit	521001	01
	STAD line regulating valve consisting of: Casing, upper part, spindle and throttling valve plug, O-ring seals made of EPDM, fitting for differential pressure and flow measurement with volume limitation, shut-off and drainage DN 20, kvs value 3.6; installation length about 91 mm, total length about 135 mm DN 25, kvs value 6.5; installation length about 110 mm, total length about 146 mm	1 unit 1 unit	270134 270135	01 01
	Connector piece made of brass, for sensors, heat meters or thermometers Dimensions: 1" IA x 1/2" IT single	1 unit	721100	01
	Immersion sleeve for WMZ feed flow sensor 1/2" ET	1 unit	720134	01
	Manifold crosspiece 1" ET x 1/2" IT x 3/8" IT	1 unit	720100	01
	Brass reducer 1" ET x 1/2" IT 1" ET x 3/4" IT 5/4" ET x 1" IT 5/4" ET x 1/2" IT	Bag 5 units Bag 5 units Bag 5 units Bag 5 units	791012 791034 791010 791112	01 01 01 01
	Immersion thermometer indicator spec. design, adjustable, 0-60 °C Red Blue	1 unit 1 unit	620060 620062	01 01
	Contact thermometer with spring for mounting to manifold or pipeline to max. 5/4" black 0-80 °C, diameter: 40 mm	1 unit	620067	01
	Zone valve with screwed connection and actuator for zone-by-zone control via room thermostat, dimensions: 3/4" ET - 3/4" IT, length: 125 mm, kvs value 5.1 with reducer 1" ET x 3/4" IT	1 unit	520027	01

Manifold technology

8.4 Control manifold

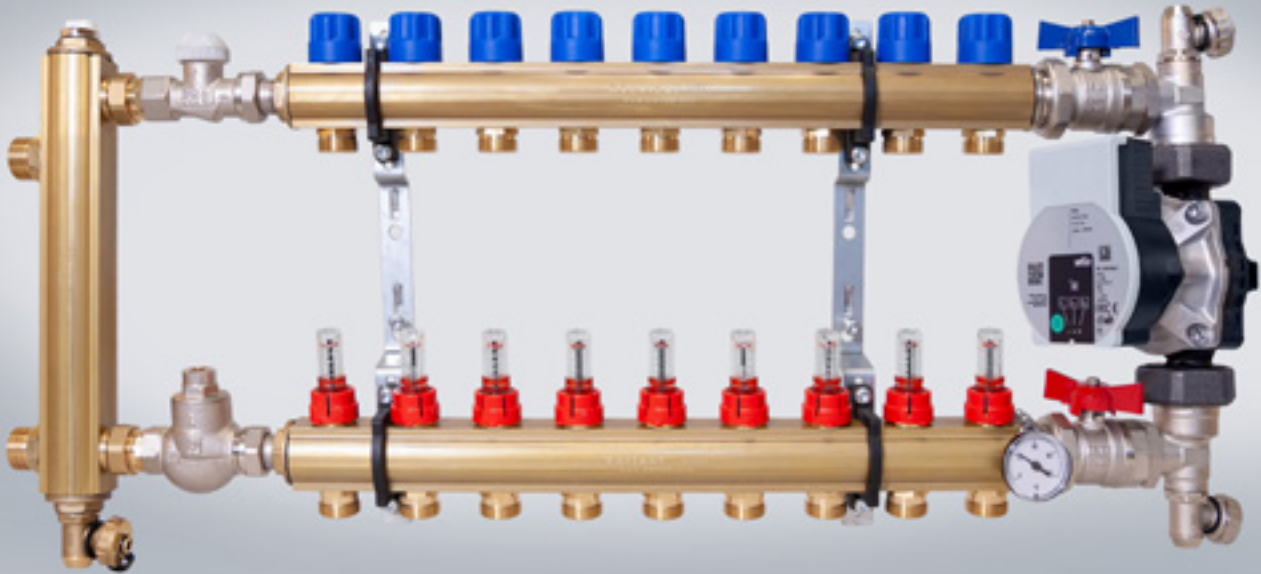

Control manifold HCM-DR with high-efficiency pump and thermoseparator, version 2.0

from 1" brass profile pipe with integrated valves and flowrate indicator

Fully assembled control manifold with pump and thermoseparator, suitable for variable or constant flow temperature control in combination with control set V or K for the hydraulic integration of low-temperature floor heating in existing heating system consisting of: Brass manifold HCM-D, high-efficiency pump, fine control valve, valve body for rule set "connection K" or "actuator control set V", 1 thermo separator, 2 shut-off valves, 2 rinsing, filling and drain valves as well as a pointer thermometer.

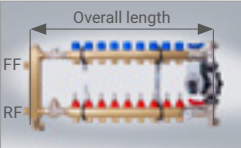
Item	Item description	Heating circuit	Manifold/ Switch	Overall length in mm**	Item No.	PG
	Control manifold HCM-DR* with high-efficiency pump and integral valves, valve clearance 50 mm factory assembled on manifold holders with inserts for noise suppression, thermo-separator with ventilation and draining. Return flow valve (above) with blue protection cap. EMPUR® actuators are pre-assembled instead, feed flow (below) with controllable and adjustable flow rate indicators (0-2.5 l/min.). Heating circuit connections 3/4" euro-conus, clamping rings ordered separately according to the pipe sizing. In carton with nameplates to identify the manifold outlets. ** Construction length incl. thermoseparator	HCM-DR 2	1"	430	250212	01
		HCM-DR 3	1"	480	250312	01
		HCM-DR 4	1"	530	250412	01
		HCM-DR 5	1"	580	250512	01
		HCM-DR 6	1"	630	250612	01
		HCM-DR 7	1"	680	250712	01
		HCM-DR 8	1"	730	250812	01
		HCM-DR 9	1"	780	250912	01
		HCM-DR 10	5/4"	860	251012	01
		HCM-DR 11	5/4"	910	251112	01
		HCM-DR 12	5/4"	960	251212	01
		HCM-DR 13	5/4"	1,010	251312	01
		HCM-DR 14	5/4"	1,060	251412	01
		HCM-DR 15	5/4"	1,110	251512	01
		HCM-DR 16	5/4"	1,160	251612	01

Compression fittings according to the pipe dimensions see page 30.

For manifold accessories, see opposite page. Allocation table see page 46, manifold cabinets see page 50/51 (plus cabinets!).





In accordance with the requirements of EC Regulation No.: 641/2009 on the energy performance of circulators, these control stations shall have an energy efficiency index (EEI) of ≤ 0.23 since 1.1.2015. The control manifold comes as standard with high-efficiency pumps. This pump falls significantly below the required value with an EEI value of ≤ 0.20 and therefore offers the possibility of immediate energy savings.

NOTE

* 5 years system warranty with exclusive use of EMPUR® components:

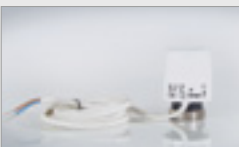
Manifolds, actuators, room operating units and control terminal strips

The water quality requirements according to VDI 2035 must be adhered to! To protect the flow rate indicator and fittings, we recommend that old systems are rinsed thoroughly and to check for the installation of a dirt trap. Use cabinets Top Standard plus or Exclusiv plus in combination with this! Thermostatic head control set K or actuator for control set V must be ordered separately! Control terminal strip with pump logic (from page 81f.) is required, overheat thermostat recommended, WMZ set upon request!

Item	Item description	PU	Item No.	PG
	Thermostatic head control set "K" for control manifold HCM-DR version 2.0 constant flow temperature control via adjustable thermostatic head, mounted on the valve body (on the return manifold, above). Capillary sensor, loose for detecting the heating circuit flow temperature, mounting on the flow manifold (below). Packaged in carton.	1 unit	520040	01
	Actuator PUR DRIVE 230 V/1,8 W/NC with adapter 28 x 1,5 control set "V" for control manifold HCM-DR, version 2.0 as a zone controller in combination with room thermostat and control terminal strips with pump logic, to be mounted on the valve body in the return flow (above).	1 unit	520030	01
	Overheat thermostat 230 V for control manifold HCM-DR, version 2.0 for limiting the max. heating circuit flow temperature on the control manifold, with capillary sensor for detecting the heating circuit flow temperature, mounting on the flow manifold (below). Adjustment range: 30-90°C, blocking of the temperature possible. Operating voltage: 230 V AC 50 Hz; 1 changeover contact 15 (2) A switching current; IP 20. Dimensions ca. 105 x 45 x 50 mm. Packaged in carton.	1 unit	510621	01
	Ball valve 3/4" nickel-plated for PUR-THERM® manifold 1" According to DIN EN 1264-4 every circuit must have two shut-off valves. For assembly on feed flow (bottom).	1 unit	722002	01
	Connection set 90° for thermoseparator consisting of: 1 STAD 3/4", 1 brass bracket 3/4" IA, 1 brass screwed connection 3/4" IA, 1 corner ball valve 3/4" 1 brass sleeve 3/4"	1 set	230042	01
	Passageway connection set for thermoseparator consisting of: 1 STAD 3/4", 1 brass screwed connection 3/4" IA, 1 ball valve passageway 3/4", 1 brass sleeve 3/4"	1 set	230032	01

CONTEMP alpha control station with high-efficiency pump and thermoseparator

for maintaining a constant feed flow temperature, for fluctuating feed flow temperatures of the heat generator

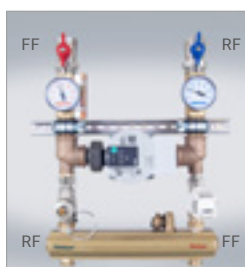

CONTEMP alpha control station with high-efficiency pump

CONTEMP 1" thermoseparator, control valve with remote sensor metering valve, pointer immersion thermometer for feed and return flow and ball shut-off valves with screwed connection.

The installation of a STAD valve for hydraulic balancing is stipulated.

Heat generator connection 3/4" ET, CONTEMP alpha 25, depending on volume flow and pressure loss suitable for areas of up to 250 m², factory design recommended!

1 unit 510705 01

Manifold technology

8.4 Control manifold

Assignment of control manifold HCM-DR incl. hydraulic separator in combination with manifold cabinets "Top Standard plus" and "Exclusiv plus"

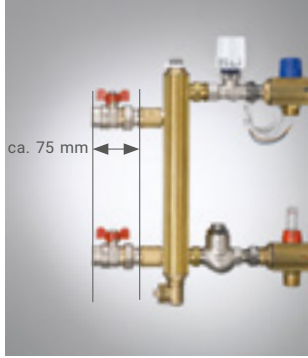

KH passageway

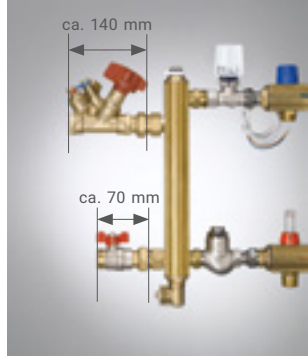

STAD passageway

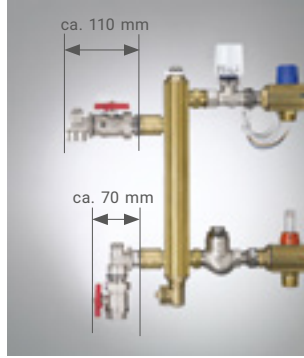

KH-90°

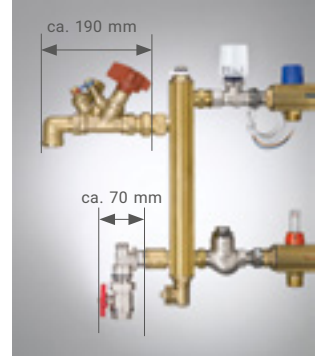

STAD-90°



Control manifold always in the "plus" manifold cabinet

HCM-DR heating circuits	KH-Passageway	STAD-Passageway	KH-90°	STAD-90°
2	720 mm	720 mm	720 mm	920 mm
3	720 mm	920 mm	920 mm	920 mm
4	920 mm	920 mm	920 mm	920 mm
5	920 mm	920 mm	920 mm	920 mm
6	920 mm	920 mm	920 mm	1,120 mm
7	920 mm	1,120 mm	1,120 mm	1,120 mm
8	1,120 mm	1,120 mm	1,120 mm	1,120 mm
9	1,120 mm	1,120 mm	1,120 mm	1,120 mm
10	1,120 mm	1,120 mm	1,120 mm	1,320 mm
11	1,320 mm	1,320 mm	1,320 mm	1,320 mm
12	1,320 mm	1,320 mm	1,320 mm	1,320 mm
13	1,320 mm	1,320 mm	1,320 mm	1,520 mm
14	1,520 mm	1,520 mm	1,520 mm	1,520 mm
15	1,520 mm	1,520 mm	1,520 mm	1,520 mm
16	1,520 mm	1,520 mm	1,520 mm	1,520 mm

Accessories f. special items	Item description	Item No.	PG
------------------------------	------------------	----------	----



Only available in combination with HCM-DR, subject to factory lay-out and pre-assembled!

Assembly accessories for WMZ connection set to 1" control manifold HCM-DR 2-9

compl. factory pre-mounted with pump, thermoseparator and selected WMZ set passageway*

EM000005 01

Assembly accessories for WMZ connection set to 5/4" control manifold HCM-DR 10-16

compl. factory pre-mounted with pump, thermoseparator and selected WMZ set passageway*

EM000006 01

*** ATTENTION! Item no. 721017 (1/2" 110 mm) or 721027 (3/4" 130 mm) see page 42, must be ordered separately! Adjust cabinet width, see data sheet!**

NOTE

The diagrams show potential installation situations. The ball valve or STAD accessories shown for connection to the thermoseparator (see page 42/43) must be ordered separately, are then supplied with the manifold or can be pre-mounted at the factory at an extra charge. Unless otherwise stated, HCM-DR manifolds are prefabricated for connection on the left, as illustrated.



Manifold cabinet "Top Standard"

for HCM 1" made of brass and stainless steel for 2-12 heating circuits (see from pages 51)

Item	Item description
------	------------------



Manifold cabinet "Top Standard" with removable back panel

for **wall-mounted assembly** in shell construction and for retrofitting on finished floors, made of sheet steel, galvanised, all visible parts foiled in white similar to RAL 9016, Height 650 mm, Depth 100 mm, available in four different sizes, removable back panel with pre-mounted top-hat rail for holding the terminal strip and suspension rail for securing the system manifold, also pre-punched left and right openings for the primary connections in the back panel, removable door with coin-operated lock, removable screed bezel

Size	Width (B) in mm	Height (H) in mm	Depth (T) in mm	Item No.	PG
1	520	650	100	268130	01
2	720	650	100	268230	01
3	920	650	100	268330	01
4	1,120	650	100	268430	01

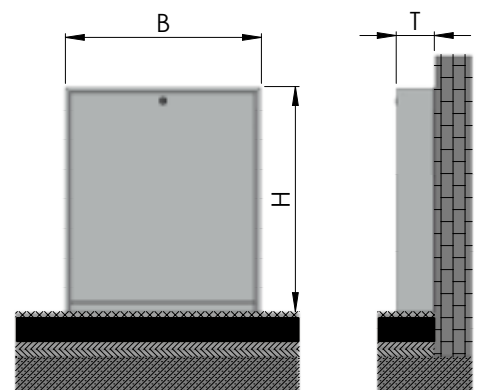
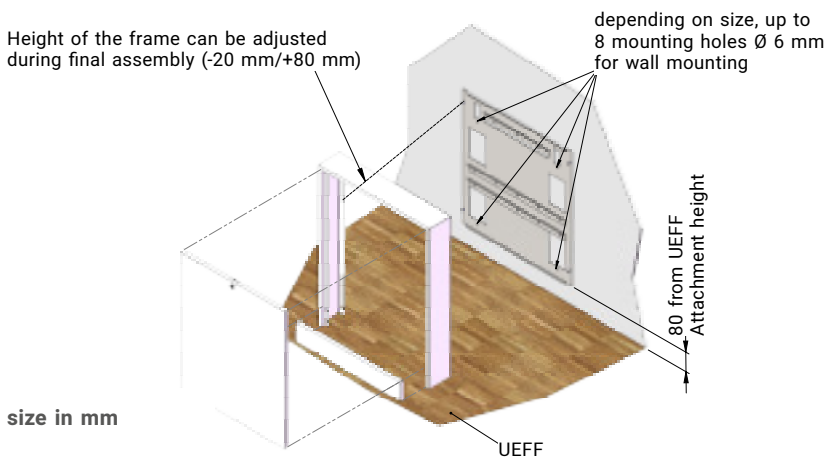

NOTE When assembling the "Top Standard" manifold cabinet, the attachment height of the back panel must be observed!

Manifold technology

8.5 Manifold cabinets

Manifold cabinet “Exclusiv”

Item	Item description
------	------------------



Manifold cabinet “Exclusiv”

for **flush-mounted installation** made of sheet steel, galvanised, all visible parts in white similar to RAL 9016, height adjustable 700-850 mm, adjustable depth 100-150 mm, available in four different sizes, Rear wall with pre-mounted top-hat rail for the regulator terminal strip and suspension rail for securing the system manifold, pre-punched left and right openings for the primary connections removable door with coin-operated lock, removable diverting rail and height adjustable screed bezel

Size	Cabinet width (B) in mm	Frame width (B1) in mm	Niche width (NB) in mm	Cabinet height (H) in mm	Cabinet height incl. frame (H1) in mm	Niche height (NH) in mm	Cabinet depth (T) in mm	Niche depth (NT) in mm	Item No.	PG
1	520	575	540	700-850	725-875	710-860	100-150	min. 110	268120	01
2	720	775	740	700-850	725-875	710-860	100-150	min. 110	268220	01
3	920	975	940	700-850	725-875	710-860	100-150	min. 110	268320	01
4	1,120	1,175	1,140	700-850	725-875	710-860	100-150	min. 110	268420	01

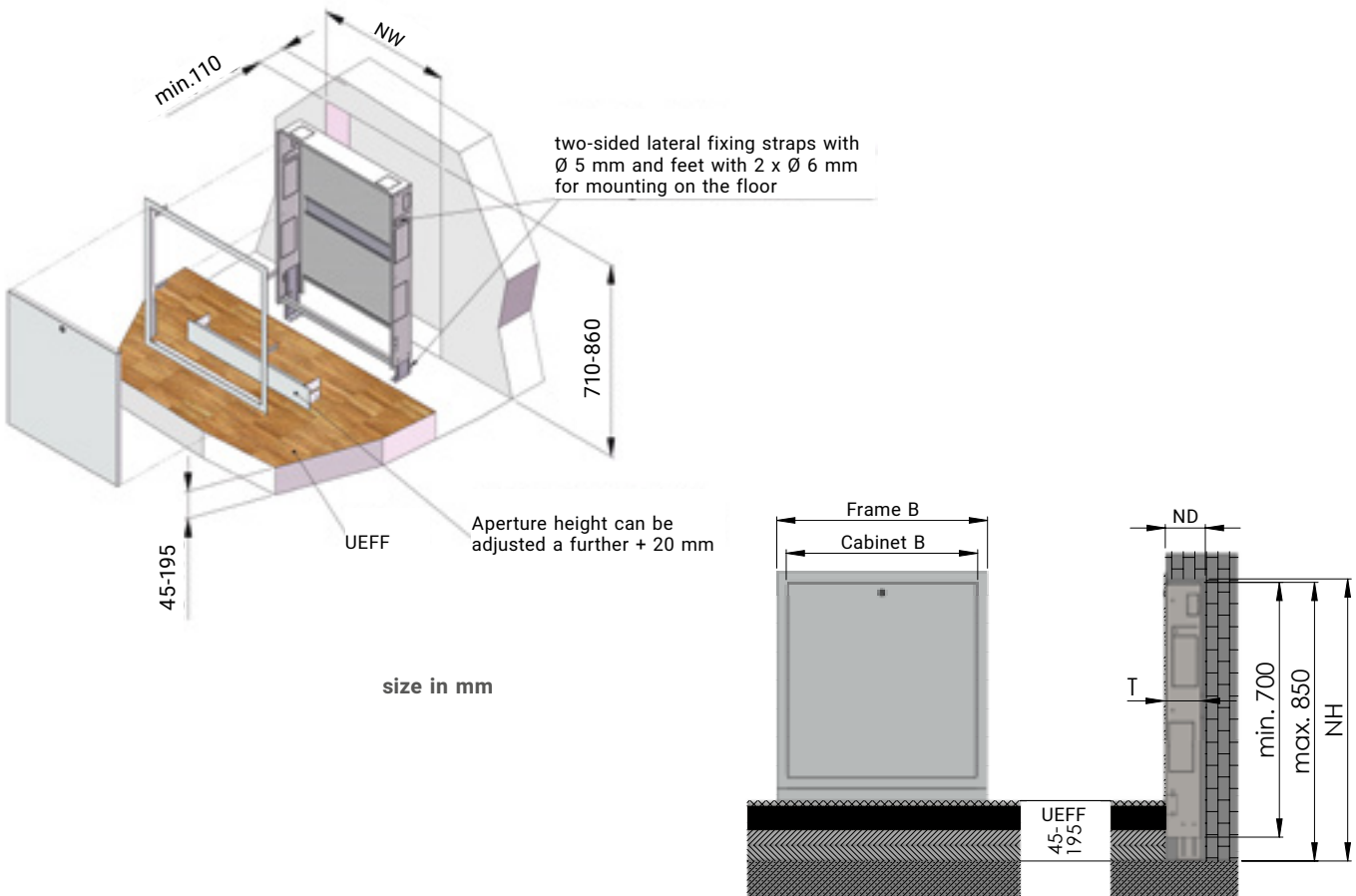

NOTE “Top Standard” and “Exclusiv” quick manifold installation in just 2 steps:

1. Position in the manifold cabinet rail
2. Fix with screws

With top-hat rail for control terminal strip, plastic door on request.

Manifold cabinet “Exclusiv superflat”

Item	Item description
------	------------------



Manifold cabinet “Exclusiv superflat”
like the manifold cabinet “Exclusiv”, but for **flush-mounted assembly in lightweight and drywall construction**, adjustable depth 75-100 mm – without diverting rail –

Size	Cabinet width (B) in mm	Frame width (B1) in mm	Niche width (NB) in mm	Cabinet height (H) in mm	Cabinet height incl. frame (H1) in mm	Niche height (NH) in mm	Cabinet depth (T) in mm	Niche depth (NT) in mm	Item No.	PG
1	520	575	540	700-850	725-875	710-860	75-100	min. 85	268140	01
2	720	775	740	700-850	725-875	710-860	75-100	min. 85	268240	01
3	920	975	940	700-850	725-875	710-860	75-100	min. 85	268340	01
4	1,120	1,175	1,140	700-850	725-875	710-860	75-100	min. 85	268440	01

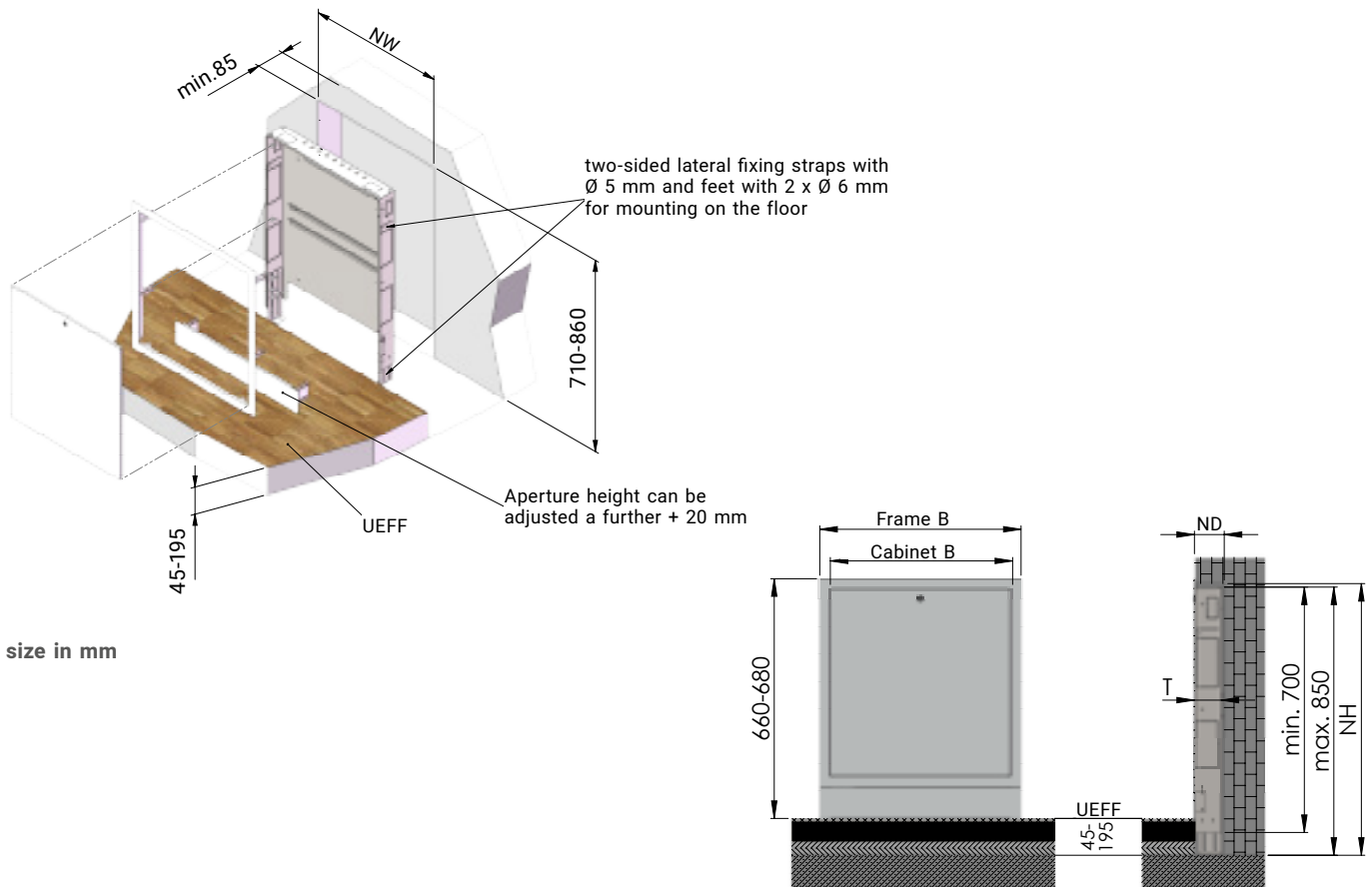

size in mm

NOTE

“Top Standard” and “Exclusiv” quick manifold installation in just 2 steps:

1. Position in the manifold cabinet rail
2. Fix with screws

With top-hat rail for control terminal strip, plastic door on request.

Manifold technology

8.5 Manifold cabinets

Manifold cabinet “Top Standard plus”

Control manifold HCM-DR 1" 2-9 Heating circuits (Page 44)

Control manifold HCM-DR 5/4" 10-16 Heating circuits (Page 44)

Industry manifold XXL 5/4" 5-16 Heating circuits (Page 91)

Item	Item description
------	------------------



Manifold cabinet “Top Standard plus” with removable back panel

for **on-the-wall mounting** in shell construction as well as for subsequent installation on finished floors, made of sheet steel, galvanised, all visible parts foiled in white, similar to RAL 9016, height 700 mm, depth 130 mm, available in five different sizes, with pre-mounted top-hat rail for holding the control terminal strip and suspension rail for fixing the system manifold, also pre-punched left and right openings for the primary connections in the back panel, removable door with coin-operated lock, removable screed bezel

Size	Width (B) in mm	Height (H) in mm	Depth (T) in mm	Item No.	PG
1	720	700	130	269135	01
2	920	700	130	269235	01
3	1,120	700	130	269335	01
4	1,320	700	130	269435	01
5	1,520	700	130	269535	01

Height of the frame can be adjusted during final assembly (-20 mm / +80 mm)

depending on size, up to 10 mounting holes Ø 6 mm for wall mounting

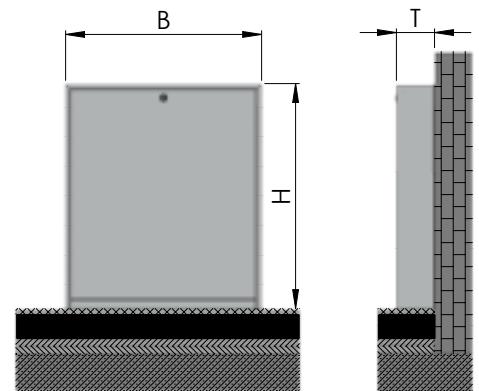
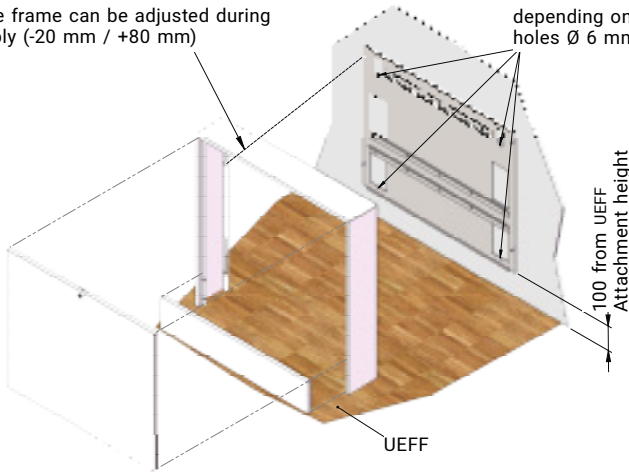

NOTE “Top Standard” and “Exclusiv” quick manifold installation in just 2 steps:
 1. Position in the manifold cabinet rail
 2. Fix with screws
 With top-hat rail for control terminal strip, plastic door on request.

Manifold cabinet “Exclusiv plus”

Item	Item description
------	------------------



Manifold cabinet “Exclusiv-plus”

for **flush-mounted installation** made of sheet steel, galvanised, all visible parts foiled in white similar to RAL 9016, height-adjustable 750-900 mm, adjustable depth 110-160 mm, available in five different sizes, pre-mounted top-hat rail on the back panel for accommodating the control terminal strip and suspension rail for securing the system manifold, pre-punched left and right openings for the primary connections, removable door with coin-operated lock, removable diverting rail and height adjustable screed bezel

Size	Cabinet width (B) in mm	Frame width (B1) in mm	Niche width (NB) in mm	Cabinet height (H) in mm	Cabinet height incl. frame (H1) in mm	Niche height (NH) in mm	Cabinet depth (T) in mm	Niche depth (NT) in mm	Item No.	PG
1	720	775	740	750-900	775-925	760-910	110-160	min. 120	269125	01
2	920	975	940	750-900	775-925	760-910	110-160	min. 120	269225	01
3	1,120	1,175	1,140	750-900	775-925	760-910	110-160	min. 120	269325	01
4	1,320	1,375	1,340	750-900	775-925	760-910	110-160	min. 120	269425	01
5	1,520	1,575	1,540	750-900	775-925	760-910	110-160	min. 120	269525	01

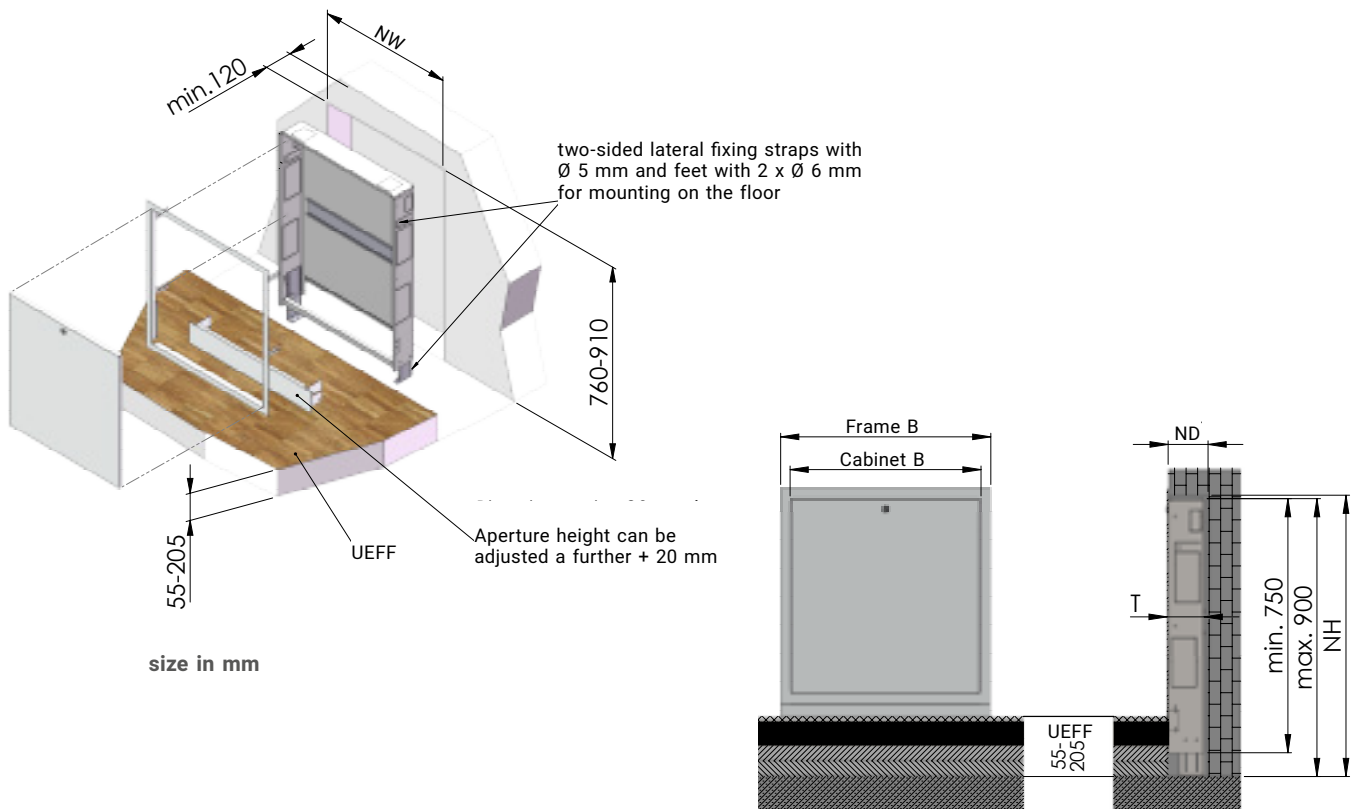

NOTE

“Top Standard” and “Exclusiv” quick manifold installation in just 2 steps:

1. Position in the manifold cabinet rail
2. Fix with screws

With top-hat rail for control terminal strip, plastic door on request.

Manifold technology

8.5 Manifold cabinets

Manifold cabinet "Economy"

The universal cabinet for housing – simple, compact and economical!

Item	Item description
------	------------------



Manifold cabinet "Economy"

made of galvanised sheet steel for **wall-mounted assembly**, all visible parts white powder coated, 4 different sizes (widths) available and packed in a box; depth 110 mm, height 585 mm
closed design, smooth side panels, supply and return connections from below, removable door with twist-lock incl. 2 manifold mounting rails and 8 mounting screws



Top-hat rail for mounting the control terminal strip is not supplied!

Size	Width (B) in mm	Height (H) in mm	Depth (T) in mm	Item No.	PG
1	550	585	110	267130	01
2	700	585	110	267230	01
3	850	585	110	267330	01
4	1.000	585	110	267430	01



Manifold cabinet "Economy"

made of galvanised sheet steel for **flush-mounted assembly**, all visible parts white powder coated, 4 different sizes (widths) available and packed in a box; depth 110 to 165 mm, height 560 to 660 mm
Supply and return connections either from left, right or below, removable door with twist-lock incl. 2 manifold mounting rails and 8 mounting screws



Top-hat rail for mounting the control terminal strip is not supplied!

Size	Cabinet width (B) in mm	Frame width (B1) in mm	Niche width (NB) in mm	Cabinet height (H) in mm	Cabinet height incl. frame (H1) in mm	Niche height (NH) in mm	Cabinet depth (T) in mm	Niche depth (NT) in mm	Item No.	PG
1	550	620	570	560-660	595-695	570-670	110-165	min. 120	267120	01
2	700	770	720	560-660	595-695	570-670	110-165	min. 120	267220	01
3	850	920	870	560-660	595-695	570-670	110-165	min. 120	267320	01
4	1,000	1,070	1,020	560-660	595-695	570-670	110-165	min. 120	267420	01

Item	Item description	PU	Item No.	PG
------	------------------	----	----------	----



Top-hat rail for mounting the base station in the manifold cabinet

Length: approx. 400 mm, packed in carton with 2 screws

Only order supplies for "Economy" manifold cabinets!

1 set 902600 01

ATTENTION: Please take into account the additional space required in the manifold cabinet (width)!

NOTE Top-hat rail for mounting a control terminal strip is not supplied!

Due to the compact cabinet dimensions (height), the additional space required for this must be taken into account horizontally where necessary and then the cabinet width increased.

Quick manifold installation not available! Plastic door not available. **Cannot be used for XXL industrial manifold (5/4"), HCM-R (1" and 5/4") and EMPUR® Geniax complete manifolds.**





We produce individual complete manifold solutions on request!

Please email your enquiries to your corresponding sales representative.

Components fully assembled according to customer specifications

- Manifold*
- Manifold cabinet
- Heat volume measurement set
- Water meter track
- Actuators*
- Control terminal strip*
- Line regulating valve
- Connection accessories

Please choose from our price list of corresponding components.

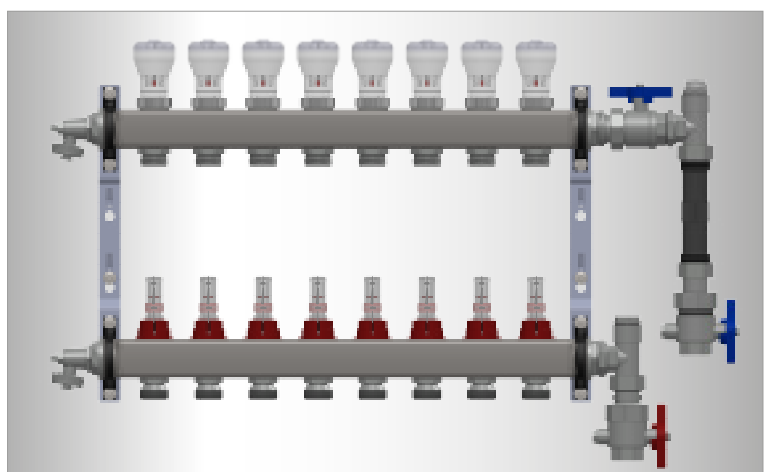
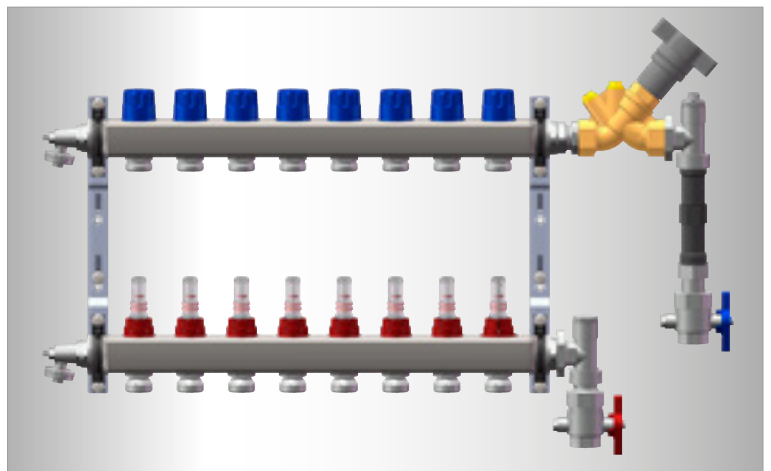

NOTE

* 5 years system warranty with exclusive use of EMPUR® components:
Manifolds, actuators, room operating units and control terminal strips

EMPUR® Geniax heat distribution system

9.1 Comfort manager for the heating

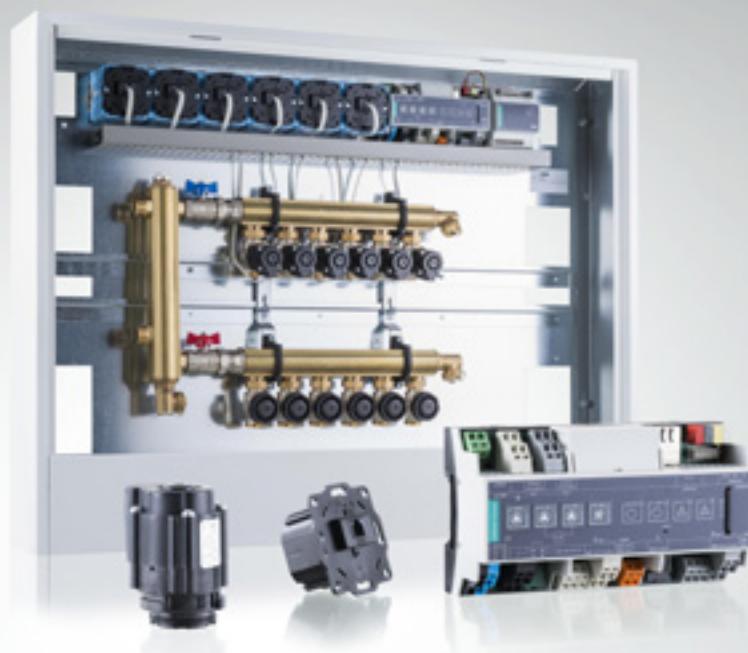

The EMPUR® Geniax heat distribution system is a **flexible surface heating and control system** which enables the **appropriate, customised heating of individual rooms in residential and non-residential buildings**.

Each heating circuit is equipped with a small, **highly-efficient glandless circulation pump** on the manifold or directly on the radiator, which often makes the central heating pump obsolete. The decentralised pumps are controlled by a **central intelligence** system, the Geniax server. This server receives its information regarding changing actual and target temperature values from control units with integrated sensors which are networked with one another using the Geniax BUS.

The combination of software-controlled temperature regulation and decentralised pumps at the heat transfer panels ensures that **each individual room is provided with the exact required heat**.

Besides the benefits which include best possible energy efficiency and **increased heating comfort**, the system is characterised by **high functionality and flexibility**.

The range of services offered by **EMPUR®** includes the manufacture and sale of Geniax components. Within the company group, the core competencies of planning and commissioning for Geniax solutions are anchored in the two independent scopes of EM-plan GmbH and EM-solution GmbH. The expert **EMPLAN®** team assists in the configuration of Geniax manifold solutions and **EMSOLUTION®** is responsible for commissioning and functional checks.

Benefits for the end-consumer

- Average 20% heating cost savings*
- Average 50% electricity cost savings*
- Additional 15% saving potential **through automatic hydraulic balancing**
- Simple and intuitive operation with smartphone, tablet or PC
- Sustainable and environmentally friendly system
- Maintains desired temperatures with individual, room-by-room adjustment of time and temperature profiles
- Quick heating function for pleasant warmth in no time at all
- Modern design in terms of shape and function

* compared to conventional heating systems

Benefits for specialised trade

- Time savings due to the **elimination of manual hydraulic balancing**
- No installation of thermostat and line regulating valves
- Installation of pump adapters with simple connection and assembly technology
- Pumps can be installed and removed when the system is full
- Can be remotely operated
- Support from **EMPLAN®/EMPUR®** during planning
- On-site service during design and commissioning by **EMSOLUTION®** service technicians

EMPUR® Geniax heat distribution system

9.1 Comfort manager for the heating

Design

EMPUR® Geniax – the comfort manager for heat distribution and cooling with decentralised pumps and room temperature control system

Note

The EMPUR® Geniax decentralised pump system consists of three component groups: Geniax pump, Geniax management and Geniax operation. The interaction between the decentralised pumps, the control units (for temperature recording and operation in each room) and the components at the management level (server, BUS, coupler, power supply...) ensures that the system functions as a whole. The decentralised pumps cannot be used without the management and operating level components.

Use

- **Hot-water heating** in combination with surface heating or radiators
- **Cooling function**

Special features / product benefits

- Safety of an optimally hydraulically balanced system with proven energy savings of 20%
- Affordable alternative to building automation with a graphical analysis option and a focus on heating and cooling
- Highest level of home and living comfort as a result of incomparable temperature stability, room-by-room control as well as time and user profiles
- High level of supply reliability due to decentralised pumps

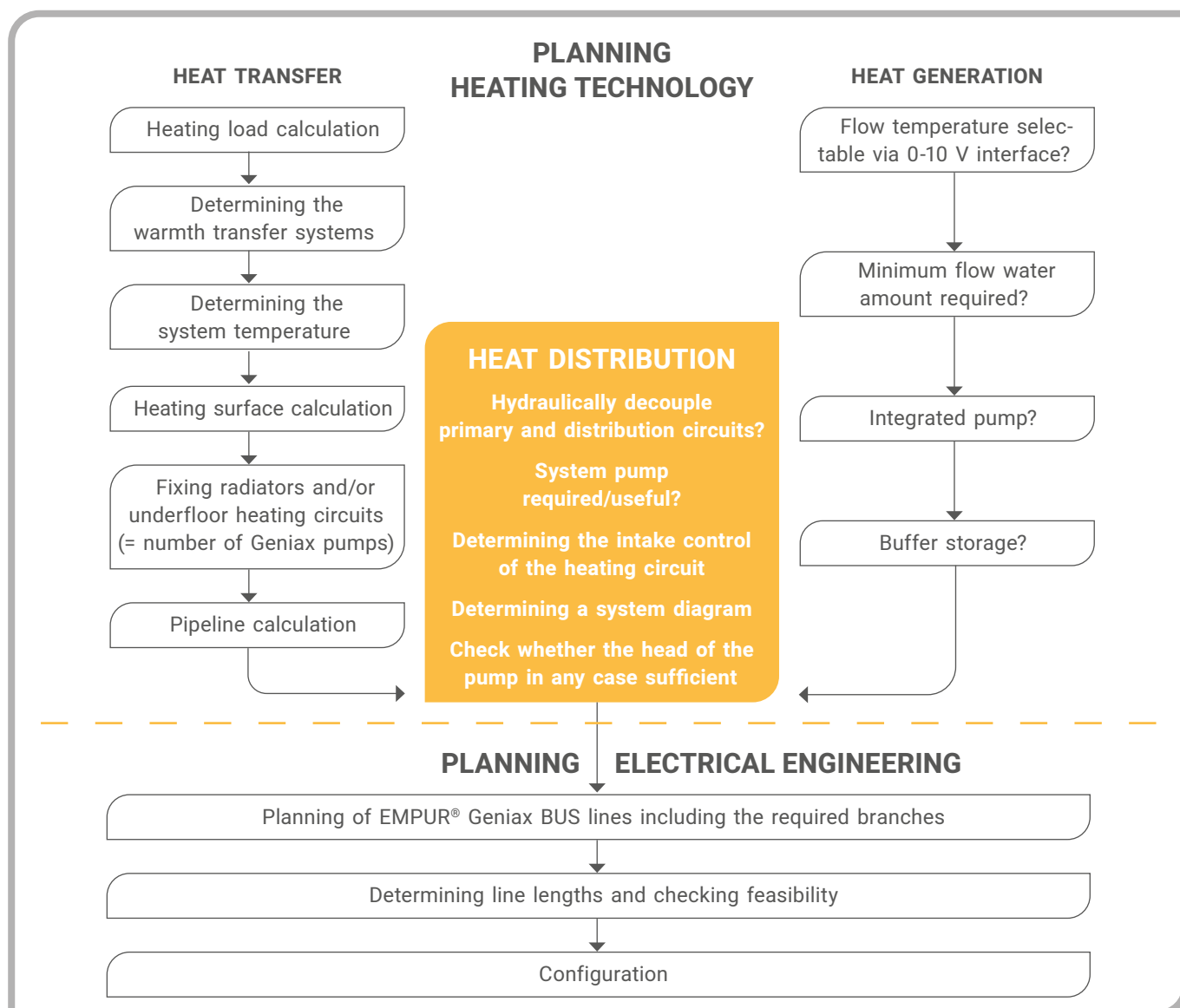

EMPUR® Geniax heat distribution system

9.2 Planning guide



Consideration of the interplay

If decentralised pumps are planned, the system must be considered as a whole. An integrated plan is then expected to create an optimum interplay of all components.

Differences to the conventional process

Planning a heating system with decentralised pumps according to the EMPUR® Geniax principle does not differ from the conventional process until the heating surface calculation. Once the pressure losses of the individual lines are known, check whether the delivery head of the decentralised heating pumps is sufficient in each case. If it is not sufficient, a solution can be found by enlarging the cross-sections of the pipes, dividing up the heating surfaces or including a feeder circuit.

When planning transfer surfaces, it is important that the decentralised heating pumps must always be installed in the return flow pipe. In addition, backflow preventers must be installed in the inflow pipe.

Mixer valves and primary mass flow throttle valves must be checked.

Building and client preferences

Of course, the starting point is the building and its specific heat requirement. The client's desire for specific warmth transfer systems such as underfloor or radiator heating together with the physical conditions provide the starting point for planning.

Heat generator

The choice of heat generator will lend the system further properties. Depending on whether the heat generator has an integrated pump and/or requires a minimum volume of circulating water, a hydraulic decoupling of the primary and secondary circuits may be required, e.g. using a hydraulic separator. To be able to make use of the flow temperature optimisation, heat generators with a 0-10 V interface are best, as they can be controlled directly by the EMPUR® Geniax server.

Heat distribution

Heat distribution must meet the defined specifications. It should also optimally make use of the decentralised pumps. The delivery head and the possible volume flow of the pumps are to be observed. You can choose from a multitude of hydraulic variants.

EMPUR® Geniax complete manifold

The unique EMPUR® Geniax pump technology in the unit together with the high-quality EMPUR® components such as the manifold, manifold cabinet etc. facilitate the installation and operation of modern surface heating systems (e.g. floor or wall heating systems) as well as conventional heating systems in heating and cooling applications.

Geniux BUS system

Once the hydraulic planning has been completed, the EMPUR® Geniux BUS must then be planned. True-to-scale building plans are an imperative prerequisite for this. The exact line lengths are required to determine an adequate power supply.

The installation location of the room control units is determined by the room layout and is normally on the inner walls. During the hydraulic planning stage, the installation locations for pumps and their electronics are fixed (distance of pump to electronics max. 1.5 m). In the vicinity of the heat generator, the next step is to determine the installation location of the control cabinet for the Geniux server and power supply.

From the server, the lines of the Geniux BUS are planned according to the specifications described in the EMPUR® Geniux planning manual. For branching, Geniux bus couplers with power supply must be provided. The same applies to longer line lengths, where a sufficient power supply can not be guaranteed with only one central power supply.

At the end of the electrical planning stage, a topological plan with all bus participants and cable paths is created. The topological plan describes the arrangement of bus participants and the cable routing in buildings, taking into account the specific characteristics of the bus participants.

Configuration

Once all components including the mass flows and the control concept are fixed, the essential details are transferred to the configuration. The configuration file created using the configuration software is saved on an SD card and inserted into the server for commissioning. In doing so, the configuration is automatically uploaded to the server. This file forms the basis for all component assignments and their control functions.

Commissioning and functional checks

Trained EMSOLUTION® customer service technicians carry out commissioning and functional checks in Germany.

The listed net prices, which do not include VAT, do not include costs for any materials required. The prices are only valid for properly installed systems.

Inspection and maintenance

Regular inspections and maintenance of systems ensure complete performance in the long term with appropriate energy utilisation and operational reliability.

By experts for experts

Our customers and partners have very different needs. That is why EMPUR® experts offer a wide range of consulting services for specialised tradesmen and planners. We support you competently and develop solutions together with you with state-of-the-art communication means. So you get the correct information that you need.

The EMPUR® Geniux helpline for specialist trade companies

- Product Information
- Answers to application questions
- Information concerning delivery times
- Spare parts advice

Phone +49 2683 96062-731

The EMPUR® Geniux helpline for planners and engineers

- Information about products, applications and documentation
- Support for product design
- Provision of technical data

Phone +49 2683 96062-732

E-mail: Geniux-Helpline@empur.com

Availability:

Monday to Thursday	7 am to 6 pm
Friday	7 am to 3 pm

Website: www.geniux.de

EMPUR® Geniax heat distribution system

9.3 Complete manifold



The unique Geniax pump technology in the unit together with the high-quality EMPUR® components such as the manifold, manifold cabinet etc. facilitate the installation and operation of modern surface heating systems (e.g. floor or wall heating systems) as well as conventional radiator systems. The advantages of individual production and the production expertise set standards in manifold technology.

EMPUR® Geniax complete stainless steel manifold

Item description	Heating circuits	Conne- ction	Overall length without switch	Cabinet width in mm*	Item No.	PG
EMPUR® Geniax complete manifold HCM-G, stainless steel						
Fully assembled in the "Exclusiv plus" flush-mounted manifold cabinet with factory assembled pump electronics and bus terminals, Geniax pumps and backflow preventer supplied loose, factory tested and logged	HCM-G 2	1" IG	200	720	280206	04
	HCM-G 3	1" IG	250	720	280306	04
	HCM-G 4	1" IG	300	720	280406	04
	HCM-G 5	1" IG	350	920	280506	04
	HCM-G 6	1" IG	400	920	280606	04
	HCM-G 7	1" IG	450	920	280706	04
	HCM-G 8	1" IG	500	920	280806	04
	HCM-G 9	1" IG	550	1,120	280906	04
	HCM-G 10	1" IG	600	1,120	281006	04
	HCM-G 11	1" IG	650	1,120	281106	04
	HCM-G 12	1" IG	700	1,120	281206	04
	EMPUR® Geniax complete manifold HCM-G, stainless steel					
Fully assembled in the "Top standard plus" surface-mounted manifold cabinet with factory assembled pump electronics and bus terminals, Geniax pumps and backflow preventer supplied loose, factory tested and logged	HCM-G 2	1" IG	200	720	280207	04
	HCM-G 3	1" IG	250	720	280307	04
	HCM-G 4	1" IG	300	720	280407	04
	HCM-G 5	1" IG	350	920	280507	04
	HCM-G 6	1" IG	400	920	280607	04
	HCM-G 7	1" IG	450	920	280707	04
	HCM-G 8	1" IG	500	920	280807	04
	HCM-G 9	1" IG	550	1,120	280907	04
	HCM-G 10	1" IG	600	1,120	281007	04
	HCM-G 11	1" IG	650	1,120	281107	04
	HCM-G 12	1" IG	700	1,120	281207	04

NOTE

* Cabinet width is designed for manifold incl. switch.

All complete manifolds can be optionally expanded with hydraulic switch in brass or stainless steel. Niche width concealed manifold cabinet = cabinet width + 20 mm. Delivery time upon request.

EMPUR® Geniax complete brass manifold

Item description	Heating circuits	Conne- ction	Overall length without switch	Cabinet width in mm*	Item No.	PG
EMPUR® Geniax complete manifold HCM-G, brass	HCM-G 2	1" IG	150	720	280202	04
Fully assembled in the "Exclusiv plus" flush-mounted	HCM-G 3	1" IG	200	720	280302	04
manifold cabinet with factory assembled pump electronics	HCM-G 4	1" IG	250	720	280402	04
and bus terminals, Geniax pumps and backflow preventer	HCM-G 5	1" IG	300	920	280502	04
supplied loose, factory tested and logged	HCM-G 6	1" IG	350	920	280602	04
	HCM-G 7	1" IG	400	920	280702	04
Brass 1" (5/4") section pipe manifold with pump adapters	HCM-G 8	1" IG	450	920	280802	04
for installation of Geniax pumps in return flow (above) and	HCM-G 9	1" IG	500	1,120	280902	04
adapters for installing the backflow preventer in the feed flow,	HCM-G 10	1" IG	550	1,120	281002	04
two manifold end-pieces with reducer for filling, bleeding and	HCM-G 11	1" IG	600	1,120	281102	04
draining, rotating, manifold holder with sound insulation insert	HCM-G 12	1" IG	650	1,120	281202	04
and identification plates	HCM-G 13	5/4" IG	700	1,320	281302	04
	HCM-G 14	5/4" IG	750	1,320	281402	04
	HCM-G 15	5/4" IG	800	1,320	281502	04
EMPUR® Geniax complete manifold HCM-G, brass	HCM-G 2	1" IG	150	720	280203	04
Fully assembled in the "Top Standard plus" surface-mounted	HCM-G 3	1" IG	200	720	280303	04
manifold cabinet with factory assembled pump electronics	HCM-G 4	1" IG	250	720	280403	04
and bus terminals, Geniax pumps and backflow preventer	HCM-G 5	1" IG	300	920	280503	04
supplied loose, factory tested and logged	HCM-G 6	1" IG	350	920	280603	04
	HCM-G 7	1" IG	400	920	280703	04
Brass 1" (5/4") section pipe manifold with pump adapters	HCM-G 8	1" IG	450	920	280803	04
for installation of Geniax pumps in return flow (above) and	HCM-G 9	1" IG	500	1,120	280903	04
adapters for installing the backflow preventer in the feed flow,	HCM-G 10	1" IG	550	1,120	281003	04
two manifold end-pieces with reducer for filling, bleeding and	HCM-G 11	1" IG	600	1,120	281103	04
draining, rotating, manifold holder with sound insulation insert	HCM-G 12	1" IG	650	1,120	281203	04
and identification plates	HCM-G 13	5/4" IG	700	1,320	281303	04
	HCM-G 14	5/4" IG	750	1,320	281403	04
	HCM-G 15	5/4" IG	800	1,320	281503	04

Thermoseparators for EMPUR® Geniax stainless steel and brass complete manifolds must be ordered separately!

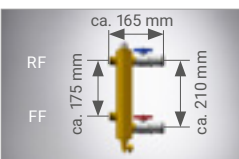
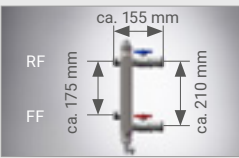
Item	Item description	PU	Item No.	PG
	Thermoseparator 5/4" brass with 3/4" ball valves for manifold installation, secondary connection 1" for distance 210 mm primary connection 3/4" ET flat sealing, distance 175 mm	1 unit	230053	04
	Thermoseparator 1" stainless steel with 3/4" ball valves for manifold installation, distance 210 mm incl. transitions primary connection 3/4" ET flat sealing, distance 175 mm	1 unit	230054	04

NOTE

Connection set for thermoseparator can be found on page 53 (Check cabinet width!). The water quality requirements according to VDI 2035 must be adhered to! With 10 outflows or more, the modules are not fully assembled! Delivery is then as a cabinet incl. accessories, packed separately and with fully assembled Geniax manifold. If self-assembly is preferred, all components and parts shall be delivered as a set. This reduces the list price of the complete manifold by € 17 per heating circuit outflow.

EMPUR® Geniax heat distribution system

9.4 Pump adapter, pump, electronics

Adapter for heaters and radiators

Item	Item description	PU	Item No.	PG
	Adapter Set Inline for connection to conventional compact heaters/radiators, set consisting of one ready-to-connect feed flow adapter and one ready-to-connect return flow adapter in passageway design each, feed flow adapter for accommodating a backflow preventer, return flow adapter for accommodating the decentralised pump	1 unit	2115496	04
	Adapter Set Corner for connection to conventional compact heaters/radiators, set consisting of one ready-to-connect feed flow adapter and one ready-to-connect return flow adapter in corner version each, feed flow adapter for accommodating a backflow preventer, return flow adapter for accommodating the decentralised pump. Depending on the adapter version, can be installed on the left or right or on alternate sides of the radiator			
	Adapter Set Corner right Adapter Set Corner left Adapter Set Corner right/left (alternate) Adapter Set Corner left/right (alternate)	1 unit 1 unit 1 unit 1 unit	2132813 2132814 2132815 2132816	04 04 04 04
	Adapter Set Angle for connection to conventional compact heaters/radiators, set consisting of one ready-to-connect feed flow adapter and one ready-to-connect return flow adapter in angle corner design each, feed flow adapter for accommodating a backflow preventer, return flow adapter for accommodating the decentralised pump, depending on the adapter version, can be installed on the left or right or on alternate sides of the radiator			
	Adapter Set Angle right Adapter Set Angle left Adapter Set Angle right/left (alternate) Adapter Set Angle left/right (alternate)	1 unit 1 unit 1 unit 1 unit	2132817 2132818 2132819 2132820	04 04 04 04
	Adapter H-Inline for connection to radiators with lower two-point connection, connection-ready pump adapter in passageway version for accommodating the decentralised heating pump EMPUR® Geniax pump as well as the backflow preventer	1 unit	2117514	04
	Adapter H-Angle (pump right) for connection to radiators with lower two-point connection, connection-ready pump adapter in corner version for accommodating the decentralised heating pump EMPUR® Geniax pump as well as the backflow preventer	1 unit	2117515	04
	Adapter H-Angle (pump left) for connection to radiators with lower two-point connection, connection-ready pump adapter in corner version for accommodating the decentralised heating pump EMPUR® Geniax pump as well as the backflow preventer	1 unit	2117516	04



EMPUR® Geniax heat distribution system

9.4 Pump adapter, pump, electronics 9.5 Complete electro-manifold

Adapter for manifold solutions

Item	Item description	PU	Item No.	PG
	<p>Adapter Set for manifold for connection to heating circuit manifold. Set consisting of two ready-to-connect adapters in passageway design for accommodating a backflow preventer and decentralised pump</p>	1 unit	2115497	04

Pump and pump electronic

Item	Item description	PU	Item No.	PG
	<p>EMPUR® Geniax Pump 1.0 for installation in the manifold flow (above) Highly-efficient glandless circulation pump with automatic power adaptation, consisting of motor with ECM technology, connection cable 1.5 m long and hydraulic unit for connection to corresponding Geniax pump adapters, power supply 24 V DC SELV</p>	1 unit	2107484	04
	<p>EMPUR® Geniax Pump electronics ready-to-connect pump electronics for control/regulation of the decentralised pump to be installed close to the pump, ready for installation in flush-mounted boxes, power supply 24 V DC SELV</p>	1 unit	2097372	04

NOTE

To complete the pump/adapter unit and ensure hydraulic function, the following is also required: **Geniax NRV set**, Item no. 2115498. Set consisting of 10 pieces of bypass with backflow preventer; Geniax accessories (see page 65).

EMPUR® Geniax complete electro-manifold

We manufacture object-related pre-assembled electrical manifolds for the Geniax system in surface-mounted or flush-mounted switch cabinets. Tested quality as a plug & play solution for rapid assembly and commissioning on site.

Item	Item description	PU	Item No.	PG
	<p>EMPUR® Geniax complete electro-manifold including Geniax server, power supply, internal cabling All connections on terminal blocks for easy wiring by the customer.</p>			
	4 rows, with 4.2 A power supply unit, pre-assembled in flush-mounted cabinet	1 unit	572070	04
	4 rows, with 2.5 A power supply unit, pre-assembled in flush-mounted cabinet	1 unit	572071	04
	4 rows, with 4.2 A power supply unit, pre-assembled in surface-mounted cabinet	1 unit	572083	04
	4 rows, with 2.5 A power supply unit, pre-assembled in surface-mounted cabinet	1 unit	572084	04
	5 rows, with 4.2 A power supply unit, pre-assembled in flush-mounted cabinet	1 unit	572072	04
	5 rows, with 2.5 A power supply unit, pre-assembled in flush-mounted cabinet	1 unit	572073	04
	<p>EMPUR® Geniax BACnet/KNX sub-distribution pre-assembled in surface-mounted cabinet, including Geniax Server, power supply, internal cabling and UGW BACnet/KNX</p>	1 unit	572074	04
	<p>All connections on terminal blocks for easy wiring by the customer. Other equipment variants on request!</p>			







EMPUR® Geniax heat distribution system

9.6 Management

Item	Item description	PU	Item No.	PG
	EMPUR® Geniax Server 2.0 connection-ready regulation and control unit, central intelligence of the Geniax system, control of all connected components, with housing according to DIN 43880 for installation in electrical manifold cabinet, power supply 24 V DC SELV	1 unit	2125135	04
	EMPUR® Geniax BUS Coupler connection-ready as complete device with housing according to DIN 43880 for installation in electrical manifold cabinet, Power supply 24 V DC SELV	1 unit	2097374	04
	EMPUR® Geniax Power Supply for mounting rail power supply 24 V DC, primary switch mode, 1phase for installation in the electrical manifold cabinet, Power supply 230 V AC/50 Hz	1 unit	2098647	04
	2.5 A	1 unit	2099206	04
	4.2 A	1 unit	2099206	04
	EMPUR® Geniax KNX Coupler connection-ready KNX interface module as complete unit for installation in the electrical manifold cabinet, Power supply 24 V DC SELV 1 KNX module max. 15 rooms, several modules can be used per Geniax server	1 unit	2137532	04
	EMPUR® Geniax UGW KNX Universal coupler KNX, 50 data points	1 unit	2137533	04
	EMPUR® Geniax UGW extension to item no. 2137533 to 200 data points	1 unit	2901701	04
	to 500 data points	1 unit	2901702	04
	to 1,000 data points	1 unit	2901703	04
	to another protocol driver e.g. BACnet, ModBus	1 unit	2137540	04
	EMPUR® Geniax UGW BACnet Universal coupler BACnet, 50 data points	1 unit	2137560	04
	EMPUR® Geniax UGW extension to item no. 2137560 to 200 data points	1 unit	2901704	04
	to 500 data points	1 unit	2901705	04
	to 1,000 data points	1 unit	2901706	04
	EMPUR® Geniax BACnet Module connection-ready BACnet interface module as complete unit for installation in the electrical manifold cabinet, Power supply 24 V DC SELV No limit of data points!	1 unit	2105645	04







EMPUR® Geniax heat distribution system

9.7 Operation

Item	Item description	PU	Item No.	PG
	<p>EMPUR® Geniax Central Control Central control unit for temperature and time-dependent operation/ control of room groups in the EMPUR® Geniax decentralised pump system, power supply 24 V DC SELV, white</p>	1 unit	2104104	04
	<p>EMPUR® Geniax Basic Control Room control unit for temperature-dependent, room-by-room operation of the EMPUR® Geniax decentralised pump system, for use in conjunction with an EMPUR® Geniax Central Control, power supply 24 V DC SELV, white</p>	1 unit	2104100	04
	<p>EMPUR® Geniax Ambient Sensor (Wall-mounted) Sensor for recording the room temperature in conjunction with an EMPUR® Geniax Central Control for wall-mounted installation, power supply 24 V DC SELV, white</p>	1 unit	2104099	04
	<p>EMPUR® Geniax Ambient Sensor i (Flush-mounted) Sensor for recording the room temperature in conjunction with an EMPUR® Geniax Central Control for flush-mounted installation, white</p>	1 unit	2131230	04
	<p>EMPUR® Geniax Licence key (for the building operator or facilities manager) Licence key for the EMPUR® Geniax PC operating software (EMPUR® Geniax SysManager). A free USB port on the PC is required to use the licence key. The following hardware and software requirements must be met to use the EMPUR® Geniax SysManager: > Windows Vista/7/8 (32 or 64-bit) > CPU Dual Core > 1 GB RAM > At least 1 GB of free hard disk space</p>	1 unit	2122546	04
	<p>EMPUR® Geniax Licence key Pro (only for specialised tradesmen) Licence key for the EMPUR® Geniax PC operating software (EMPUR® Geniax SysManager), A free USB port on the PC is required to use the licence key. The following hardware and software requirements must be met to use the EMPUR® Geniax SysManager: > Windows Vista/7/8 (32 or 64-bit) > CPU Dual Core > 1 GB RAM > At least 1 GB of free hard disk space</p>	1 unit	2122547	04









EMPUR® Geniax heat distribution system

9.8 Design accessories

Item	Item description	PU	Item No.	PG
	Design Cover S Use in conjunction with the passageway Adapter Set Radiator, for complete coverage of the feed flow adapter including the mounted backflow preventer, white	1 unit	2117408	04
	Design Cover M Use in conjunction with the passageway Adapter Set Radiators, for complete coverage of the return flow adapter including the mounted pump, white	1 unit	2101232	04
	Design Cover MC Use in conjunction with the corner or Adapter Set Corner, for complete coverage of the return flow adapter including the mounted pump, white	1 unit	2132821	04
	Design Cover SC Use in conjunction with the corner or Adapter Set Corner or Adapter Set Angle, for complete coverage of the feed flow adapter including the mounted backflow preventer, white	1 unit	2132822	04
	Design Cover L Use in conjunction with the Adapter Set H-Inline or H-Angle, for complete coverage of the adapter including the mounted pump and mounted backflow preventer, white	1 unit	2101230	04
	Design Cover Electronic For complete coverage of the Geniax Pump Tronic as well as for accommodating the pump connection cable, white	1 unit	2104098	04

EMPUR® Geniax heat distribution system

9.9 System accessories

Item	Item description	PU	Item No.	PG
	Reducing double nipple R¹/₂ x R³/₄ self-sealing reducing double nipple R ¹ / ₂ x R ³ / ₄ , for assembling the Geniax Adapter H-Inline/H-Angle onto radiators with lower two-point connection	Bag 20 units	2098646	04
	Eurokonus levelling piece self-sealing levelling piece with Eurokonus, for assembling the Geniax Adapter H-Inline/H-Angle onto radiators with lower two-point connection	Bag 20 units	2098649	04
	NRV set Bypass with integrated backflow preventer, for replacing the bypass inserted into the adapters at the factory (before commissioning the EMPUR® Geniax system)	Car 10 units	2115498	04
	Assembly aid for simplified assembly/disassembly of the decentralised Geniax pump as well as the bypass on all Geniax adapters, for opening and closing the bypasses or the flow at the pump adapters	1 unit	2115889	04
	Flow temperature sensor for heating circuits (PT 1000) for recording the flow temperatures of the heating circuits (3 m cable length)	1 unit	2101235	04
	Surface sensor for underfloor heating	1 unit	2101237	04
	Immersion sleeve for accommodating the flow temperature sensor for heating circuits	1 unit	2101233	04
	External temperature sensor (PT 1000) with housing	1 unit	2101238	04
	BUS tester for checking or for limited fault diagnosis of EMPUR® Geniax BUS segments during installation and commissioning	1 unit	2132766	04

EMPUR® Geniux heat distribution system

9.10 Heatfixx



Design

Retrofit set for under-supplied heating surfaces, consisting of:

- Heatfixx pumps: High-efficiency glandless circulation pump with fixed speed and EC motor, connection cable and hydraulic unit for connection to the corresponding Heatfixx pump adapters
- Heatfixx electronics box
- Heatfixx remote room thermostat

Use

The **Heatfixx retrofit set** is intended for **stand-alone use for under-supplied heating surfaces in residential and commercial areas as well as in small businesses**. The set is not suitable for single-pipe heating and industrial applications.

Special features / product benefits

- No additional planning or complex configuration
- Easy handling without special tools or special training
- Uncomplicated assembly without major structural intervention
- Manageable time expenditure as a result of well-known installation technology
- Universal use for commercially available heating surfaces

Scope of delivery

Heatfixx wall-mounted assembly set, complete with









- Electronic box incl. mains plug for 230 V AC, power supply 24 V DC, Heatfixx module (pump electronics) and radio receiver for EnOcean® signals
- Heatfixx pump 1.0
- Remote room thermostat
- Adhesive strips for wall mounting of the remote room thermostat
- Batteries 3.6 V/1.1, Ah Type LS14250 1/2AA (for remote room thermostat)
- Installation and operating manual
- Assembly template for electronics box

Heatfixx flush-mounted assembly set, complete with

- Electronics box for flush-mounted installation, power supply 24 V DC, Heatfixx module (pump electronics) and radio receiver for EnOcean® signals
- Heatfixx pump 1.0
- Remote room thermostat
- Adhesive strips for wall mounting of the remote room thermostat

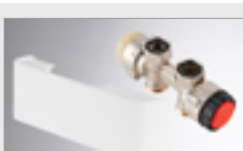
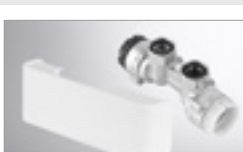
EMPUR® Geniux heat distribution system

9.10 Heatfixx

Example set	Item description	PU	Item No.	PG
	Heatfixx flush-mounted assembly set for assembly on triple flush-mounted switch box/D = 60 mm Dimensions: 223 x 85 x 51 mm	1 unit	2139419	06
	Heatfixx wall-mounted assembly set Dimensions: 223 x 85 x 58 mm	1 unit	2139420	06
	Heatfixx Adapter Inline and Design Cover M	1 unit	2140204	06
	Heatfixx Adapter Corner right and Design Cover MC (for mounting the pump on the right side of the heating surface, rear outlet)	1 unit	2140205	06
	Heatfixx Adapter Corner left and Design Cover MC (for mounting the pump on the left side of the heating surface, rear outlet)	1 unit	2140206	06
	Heatfixx Adapter H-Inline and Design Cover L (for mounting the pump on either the left or right of the heating surface)	1 unit	2140207	06
	Heatfixx Adapter H-Angle right and Design Cover L (for mounting the pump on the right side of the heating surface)	1 unit	2140208	06
	Heatfixx Adapter H-Angle left and Design Cover L (for mounting the pump on the left side of the heating surface)	1 unit	2140209	06
	Heatfixx Adapter Angle right and Design Cover MC (for mounting the pump on the right side of the heating surface, bottom outlet)	1 unit	2145119	06
	Heatfixx Adapter Angle left and Design Cover MC (for mounting the pump on the left side of the heating surface, bottom outlet)	1 unit	2145120	06
	Assembly aid for pump and adapter (see page 65)	1 unit	2115889	06





EMPUR® Geniax heat distribution system

9.11 Service

Configuration

Item	Item description	PU	Item No.	PG
	<p>Configuration Geniax Server < 50 pumps</p> <p>Creation of the server configuration for the decentralised pump system EMPUR® Geniax with < 50 pumps, Creation of the topology and server configuration, Configuration is carried out according to the client's specifications for nomenclature, setpoints, weekly time programs and further configuration parameters</p>	1 unit	572065	05
	<p>Configuration Geniax Server < 100 pumps</p> <p>Creation of the server configuration for the decentralised pump system EMPUR® Geniax with < 100 pumps, Creation of the topology and server configuration, Configuration is carried out according to the client's specifications for nomenclature, setpoints, weekly time programs and further configuration parameters</p>	1 unit	572066	05
	<p>Configuration Geniax Server > 100 pumps</p> <p>Creation of the server configuration for the decentralised pump system EMPUR® Geniax with > 100 pumps, Creation of the topology and server configuration, Configuration is carried out according to the client's specifications for labels, set-points, weekly programmes and further configuration parameters, billed according to costs</p>	1 hr	572067	05
	<p>Geniax KNX (2137532) configuration</p> <p>Creation of the KNX server configuration for the EMPUR® Geniax decentralised pump system, Adaptation of the existing topology and server configuration to the corresponding KNX objects, setting of the group addresses and all necessary device settings. This is based on the existing and already implemented object-specific server configuration as well as the transfer of KNX group addresses specified by the client</p>	1 unit	572061	05
	<p>Geniax BACnet (2105645) configuration</p> <p>Adaptation of the existing topology and server configuration, Creation of the configuration for the BACnet module as well as all necessary BACnet objects, creation of an EDE list for the BACnet objects in agreement with the BMS supplier or building automation. This is based on the existing and already implemented object-specific server configuration, billed per module.</p>	1 unit	2120425	05
	<p>Geniax UGW KNX/BACnet (2137533 + 2137560) configuration</p> <p>Creation of the KNX/BACnet and configuring the EMPUR® Geniax decentralised pump system, Adaptation of the existing topology and server configuration Creation of the gateway configuration with the corresponding KNX or BACnet objects based on the existing and already implemented object-specific server configuration as well as the transfer of the necessary information for configuration by the client, billed according to costs</p>	1 hr	2137530	05

Commissioning

Item	Item description	PU	Item No.	PG
	<p>Commissioning Geniax Server</p> <p>Initial commissioning of a Geniax Server in accordance with the creator and/or the object-specific design, training on all system components, hydraulic and electrical testing of the Geniax components and the overall system, commissioning and functional testing, documentation, instruction of and handover to the customer. This is based on the existing and already implemented object-specific server configuration as well as assembly and wiring of all components, billed according to costs plus travel expenses</p>	1 hr	572060	05
	<p>Commissioning KNX/BACnet</p> <p>Initial commissioning of a Geniax BACnet, Geniax UGW BACnet or KNX UGW module, check the BACnet/KNX objects transferred via the interface, for affiliation and functionality, the test is based on the EDE list created in the configuration, it is not a 1:1 data point test, but a point-by-point data point test, billed according to costs plus travel expenses</p>	1 hr	2120426	05
	<p>Geniax support</p> <p>billed at an hourly rate for unforeseen services in relation to the configuration and/or commissioning of a Geniax system, billed according to costs plus travel expenses</p>	1 hr	2120428	05
	<p>Travel expenses</p> <p>Outward and return per kilometre travelled</p>	1 km	572081	05



NOTE Commissioning and function check by trained customer service technicians within Germany. Inspection/maintenance: Regular inspections and maintenance of systems ensure full performance with corresponding energy utilisation and operational safety in the long term.

Control technology

10.1 Actuators



Actuators control technology



Item	Item description	PU	Item No.	PG
	<p>Actuator "Economy", normally closed*</p> <p>For easy mounting on EMPUR® brass/stainless steel manifolds with connection thread M 30 x 1.5. Protection type IP 42 in all mounting positions (also overhead), protection class II, ambient temperature: 0-50 °C, opening/closing time approx. 1.5 min., connecting cable 0.8 m/2 x 0.5 mm², position indicator 2-fold available (top and side)</p> <p style="color: red; font-weight: bold; font-size: 1.2em;">No longer included in the product range!</p>			
	230 V/2 W/NC actuator	20 units	552309	01
	24 V/2 W/NC actuator	10 units	552310	01
	<p>Actuator with assembly aid "Man Open", normally closed*</p> <p>For easy mounting on EMPUR® brass/stainless steel manifolds with connection thread M30x1.5. Protection type IP 54, protection class II, ambient temperature: max. 60 °C, opening/closing time: approx. 3-5 min., connecting cable 0.8 m/2x0.75 mm²</p>			
	230 V/2 W/NC actuator with adapter ring M 30x1,5	20 units	553120	01
	24 V/2 W/NC actuator with adapter ring M 30x1,5	10 units	553140	01
	<p>The possibility of manual opening makes maintenance work much easier in addition to simple assembly. The valve can be opened in particular for commissioning without electrical connection. In the "Man" position, there is a permanent flow is ensured.</p> <p>ATTENTION: In control mode, the actuator must be in the "Auto" position. Do not mount overhead!</p>			
	<p>DDC actuator 24 V AC, control 0-10 V DC signal*</p> <p>with adapters for valves 30x1.5 mm, 1 m connection cable pluggable, 3x0.22 m² white normally closed (NC), 1 W power consumption, "First open function", protection type IP 54 in any mounting position</p>			
		1 unit	550101	01

NOTE

* 5 years system warranty with exclusive use of EMPUR® components: Manifolds, actuators, room operating units and control terminal strips



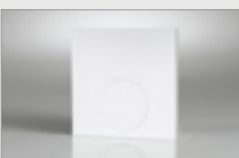



Standard Heating control technology

Item	Item description	PU	Item No.	PG
	<p>Room operating unit 230 V/24 V analogue standard heating Adjustment range target temperature 10-28 °C, lowering input with fixed lowering temperature. 4 °C, frost protection, IP 20 protection type, protection class: II (230 V), III (24 V), screw terminal connections for max. (5x) 1.5 mm²; Dimensions: 86 x 86 x 29 mm, ABS casing, white, set point adjuster with bar display (without set point limiter), Switching differential ± 0.5 K</p> <p>230 V Analogue heating Operating voltage 230 V/50 Hz, max. switching capacity 2 A, max. 30 W resistive load (200 VA inductive)/fuse T2AH</p> <p>24 V Analogue heating Operating voltage 24 V/max. switching capacity 1 A, max. 15 W resistive load/fuse T1A</p>	1 unit	574103	01
	<p>Room sensor 230 V standard heating (public building model) with hidden controls for use in public areas Setting range 10-28 °C, lowering input with fixed lowering temperature 2 K, frost protection function from 6 °C, protection type IP20, protection class: II Operating voltage 230 V/50 Hz, max. switching capacity 1.8 A, max. 30 W resistive load (200 VA inductive)/fuse T 2 AH Dimensions: 86 x 86 x 26 mm, white housing</p>	1 unit	574105	01
	<p>Room operating unit 230 V/24 V Display Standard heating Adjustment range target temperature 5-30 °C , frost and valve protection Screw terminal connections for max. 1.5 mm² Dimensions: 86 x 86 x 31 mm; ABS casing, white**</p> <p>230 V Display heating Operating voltage 230 V/50 Hz, max. switching capacity 1A, max. 5 W, resistive load (200 VA inductive)/fuse T1AH, protection type IP20, Class II (230 V)</p> <p>24 V Display heating Operating voltage 24 V/max. switching capacity 1 A, max. 5 W resistive load/fuse T1A, IP20 protection, protection class III (24 V)</p>	1 unit	572308	01
		1 unit	572307	01

** Surface-mounted housing for mounting on flat wall or on flush-mounted box

Control technology

10.2 Standard Heating

Item	Item description	PU	Item No.	PG
	Cover frame, white Dimensions 94 x 94 mm, for all room control units 86 x 86 mm, for wall mounting under the room control unit	1 unit	572890	01
NEW				
	Regulator terminal strip 6 or 10 zones 230 V Standard heating Operating voltage 230 V/50 Hz, max. power consumption 50 VA, max. nominal load of all actuators 24 W, fuse protection T4A, inrush current per actuator max. 500 mA, integrated standard-compliant strain relief, screwless terminal technology for connection cross-section up to max. 1.5 mm ² , two separate lowering channels for control via external timer signal, protection type IP20, protection class II, dimensions (H/W/D): 90 x 327 x 50 mm, ABS casing, light grey, cover transparent 6 zones for: 6 room control units/max. 15 actuators 230 V NC (zones x number of terminals: 1x5+1x4+2x2+2x1) 10 zones for: 10 room control units/max. 18 actuators 230 V NC (zones x number of terminals: 1x5+1x4+4x2+4x1)	1 unit	572333	01
		1 unit	572334	01
	Regulator terminal strip 6 or 10 zones 24 V Standard heating incl. system transformer 230 V/24 V, max. power consumption 30 VA (no-load <0.5 W) max. nominal load of all drives 24 W, fuse protection T2A, integrated standard-compliant strain relief, screwless terminal technology for connection cross-section up to max. 1.5 mm ² , two separate lowering channels for control via external timer signal, protection type IP20, protection class III, dimensions (H/W/D): 90 x 327 x 50 mm, ABS casing, light grey, cover transparent 6 zones for: 6 room control units/max. 15 actuators 24 V NC (zones x number of terminals: 1x5+1x4+2x2+2x1) 10 zones for: 10 room control units/max. 18 actuators 24 V NC (zones x number of terminals: 1x5+1x4+4x2+4x1)	1 unit	572343	01
		1 unit	572344	01

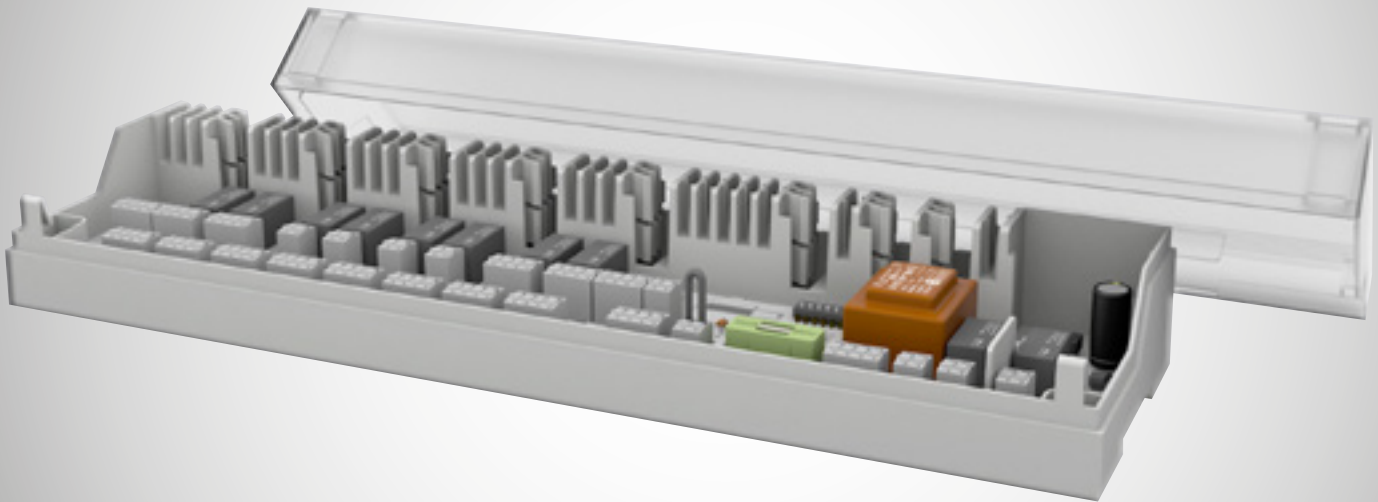

Balance control terminal strip

The **Balance control terminal strip is the intelligent individual room controller** for maximum comfort and energy efficiency in surface temperature control in combination with our brass manifolds version 2.0 and the stainless steel manifold series 03 (page 45ff).

The Balance control terminal strip with **integrated, TÜV-certified "automatic hydraulic balancing"** carries out balancing completely independently without using additional hardware or software and is therefore eligible for funding. The system's control characteristics ensure automatic balancing of the flow rate at the manifold in the connected heating circuits, making it at least equivalent to manual hydraulic balancing according to the TÜV certificate.

Item	Item description	PU	Item No.	PG
	<p>Control terminal strip Balance heating/cooling Operating voltage: 230 V / ±10% / 50-60 Hz Power consumption in idle mode: max. 1 W Dimension (H/W/D): 90 mm x 327 mm x 52 mm, weight: 600 g Protection: T4AH, operating status indication by LEDs, function "Disable cooling", heat generator and pump control (pump logic function), dew point sensor or safety temperature monitor connection, change-over signal (CO) for heating/cooling change-over, setback input, protection class IP20, protection class II, housing ABS light grey, Cover transparent</p> <p>8 zones for 8 room operating units/max. 17 actuators 230 V NC (zones x number of terminals: 1x5+1x4+2x2+4x1)</p>	1 unit	574113	01

With the Balance control terminal strip, the applicant has a very simple option with which to apply for funding. For this purpose, after completion of the measures, only the following text is added to the VDZ (Association of the German Central Heating Industry) form as part of the verification:

"The hydraulic balancing of the surface temperature control was carried out with an automatic TÜV-certified system (certificate no.: AHBHS_268065243 and test mark number: 72544)."



NOTE

All 230 V standard heating controllers (page 71) can be used! The system recognises the specification and automatically adjusts to it. No heating-cooling controllers required! By inverting the input signals of standard heating controllers, the Balance control terminal strip can thus map the cooling function in addition to the heating function. All 230 V NC version thermal actuators (page 70) are still suitable as actuators.

Control technology





10.4 Standard plus Heating/Cooling



Standard plus Heating/Cooling control technology

Item	Item description	PU	Item No.	PG
	<p>Room operating unit 230 V/24 V analogue standard plus heating/cooling* Adjustment range target temperature 10-28 °C, frost protection function Lowering input with fixed lowering temperature 4 °C, changeover input (heating/cooling switch), with function "suspend cooling", Screw terminal connections for max. (5x) 1.5 mm², Dimensions: 86 x 86 x 29 mm; ABS casing, white*, set point adjuster with figures (without set point limiter)</p> <p>230 V Analogue heating/cooling Operating voltage 230 V/50 Hz, max. switching capacity 2A, max. 30 W resistive load (200 VA inductive)/fuse T2AH, protection type IP20, Class II (230 V)</p> <p>24 V Analogue heating/cooling Operating voltage 24 V/max. switching capacity 1 A, max. 15 W resistive load/fuse T1A, IP20 protection, protection class III (24 V)</p>	1 unit	574101	01
	<p>Room operating unit 230 V/24 V Display Standard plus heating/cooling* PI-controller, Changeover input (CO signal), lowering output (switching signal), adjustable temperatures (5-30 °C) for day and night (for heating and cooling), adjustable time programmes (days/week), selectable opera- ting mode: day/night/auto, internal timer (date and time), power reserve (10 h), correction of actual temperature (± 2K), setpoint temperature limitation, valve and frost protection function, deactivatable switching outputs (e.g. suspend cooling), child safety lock (control lock), ground sensor connection, Screw terminal connections for max. (7x) 1.5 mm², Dimensions (H x W x D): 86 x 86 x 31 mm; ABS casing, white**</p> <p>230 V Display heating/cooling Operating voltage 230 V/50 Hz, max. switching capacity 1A, max. 15 W, resistive load (200 VA inductive)/fuse T1AH, protection type IP20, Class II (230 V)</p> <p>24 V Display heating/cooling Operating voltage 24 V/max. switching capacity 1 A, max. 15 W resistive load/fuse T1A, IP20 protection, protection class III (24 V)</p>	1 unit	574102	01
	<p>Floor sensors (NTC) 0-50 °C as accessories for room operating unit 230 V/24 V Display Standard plus heating/cooling 3 m cable length (2 x 0.75 m²), protection type IP67</p>	1 unit	584022	01

** Surface-mounted housing
for mounting on flat wall or
on flush-mounted box

Item	Item description	PU	Item No.	PG
	Cover frame, white Dimensions 94 x 94 mm, for all room control units 86 x 86 mm, for wall mounting under the room control unit	1 unit	572890	01
NEW				
	Regulator terminal strip 6 or 10 zones 230 V Standard plus heating/cooling* Operating voltage 230 V/50 Hz, max. power consumption 50 VA, max. rated load of all actuators 24 W, fuse protection T4AH, inrush current per actuator max. 500 mA, integrated standard-compliant strain relief, screwless terminal technology for connection cross-section up to max. 1.5 mm ² , change-over input switchable via potential-free contact (heating/cooling change-over), pump control (normally open contact, single-pole switching), signal input for temperature limiter or dew point sensor, two separate lowering channels for control via external timer signal, protection type IP20, protection class II, dimensions (H/W/D): 90 x 327 x 50 mm, ABS casing, light grey, cover transparent			
	6 zones for: 6 room control units/max. 15 actuators 230 V NC (zones x number of terminals: 1x5+1x4+2x2+2x1)	1 unit	574111	01
	10 zones for: 10 room control units/max. 18 actuators 230 V NC (zones x number of terminals: 1x5+1x4+4x2+4x1)	1 unit	574112	01
	Regulator terminal strip 6 or 10 zones 24 V Standard plus heating/cooling* incl. system transformer 230 V/24 V, max. power consumption 30 VA (no-load <0.5 W) max. rated load of all drives 24 W, fuse protection T2A, integrated standard-compliant strain relief, screwless terminal technology for connection cross-section up to max. 1.5 mm ² , change-over input switchable via potential-free contact (heating/ cooling change-over), pump control (normally open contact, single-pole switching), signal input for temperature limiter or dew point sensor, two separate lowering channels for control via external timer signal, protection type IP20, protection class III, dimensions (H/W/D): 90 x 327 x 50 mm, ABS casing, light grey, cover transparent			
				
	6 zones for: 6 room control units/max. 15 actuators 24 V NC (zones x number of terminals: 1x5+1x4+2x2+2x1)	1 unit	574141	01
	10 zones for: 10 room control units/max. 18 actuators 24 V NC (zones x number of terminals: 1x5+1x4+4x2+4x1)	1 unit	574142	01
NOTE	Can be combined with humidity monitoring as an option Item no. 585020 or 585021 (see page 81)			
	Top-hat rail for mounting the base station in the manifold cabinet Length: approx. 400 mm, packed in carton with 2 screws Only order supplies for "Economy" manifold cabinets! ATTENTION: Please take into account the additional space required in the manifold cabinet (width)!	1 set	902600	01

NOTE * 5 years system warranty with exclusive use of EMPUR® components:
 Manifolds, actuators, room operating units and control terminal strips

Control technology

10.5 Radio



Radio control technology

With the latest generation in convenient individual room control, you can maximise your energy efficiency and user comfort at the highest level. The modular control system offers individual solutions for new builds and renovation projects. The system is ideal for family homes or apartment buildings, administrative and commercial buildings, as well as hotels and schools. Integration into automation systems is possible.

The Exclusiv control technology (radio/BUS) also has the option to control your heating system via Smartphone and PC.

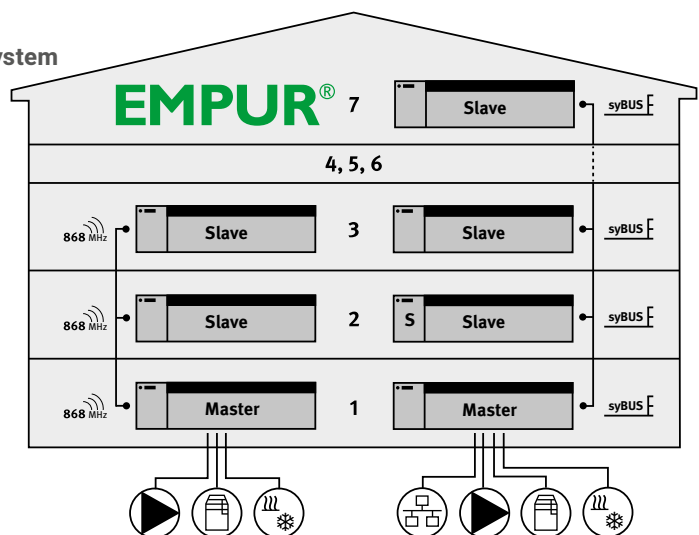

- Perfect interplay of control systems over several storeys via serial bus (syBUS)
- Ethernet interface for simple, room-by-room operation, programming and set-up of the individual room control system as well as status visualisation via PC or smartphone
- Intuitive operation, central programming, simple initialisation
- Up 20% energy saving possible through intelligent control
- Individual programming and setting per heating zone
- Secure communication between the system components
- TÜV certified automatic hydraulic balancing
- Integrated system clock



With the Exclusiv control technology radio/BUS, the applicant has a very simple option with which to apply for funding. For this purpose, after completion of the measures, only the following text is added to the VDZ (Association of the German Central Heating Industry) form as part of the verification:

"The hydraulic balancing of the surface temperature control was carried out with an automatic TÜV-certified system (certificate no.: AHBHS_12575199 and test mark number: 72544)."





Item	Item description	PU	Item No.	PG
	<p>Radio basis station 230 V 868 MHz* Central module for all information processing and communication with the system components.</p> <p>Up to 7 base stations can be linked via radio frequency. Simple, intuitive installation with clamp and plug-in technology, pilot function for heating and cooling via boiler output, central switching via external signal, dew-point monitoring via potential-free contact, integrated pump module including pump protection function, connection for safety temperature limiter, anti-freeze function, emergency operation, monitoring of the floor temperature in combination with the floor sensors, valve protection function at all outputs, for top-hat rail mounting, max. rated load of all actuators 24 W</p>			
	<p>4 zones for: 4 operator units/6 actuators 230 V (zones x number of terminals: 2x2+2x1) Dimensions: 225 x 52 x 75 mm</p>	1 unit	585014	01
	<p>8 zones for: 8 operator units/12 actuators 230 V (zones x number of terminals: 4x2+4x1) Dimensions: 290 x 52 x 75 mm</p>	1 unit	585015	01
	<p>12 zones for: 12 operator units/18 actuators 230 V (zones x number of terminals: 6x2+6x1) Dimensions: 355 x 52 x 75 mm</p>	1 unit	585016	01
	<p>Wireless base station 230 V 868 MHz* for one room control unit and one actuator (max. 10 W) with pump logic</p> <p>for wall-mounted and flush-mounted box assembly Dimensions: 86 x 86 x 33 mm Colour: Casing pure white (RAL 9003)</p>			
1 zone version	<p>for a heating or cooling zone, LED button for status display and easy programming, Screwless spring/clamp connection technology with strain relief, Micro SD card slot for easy configuration and software updates (card not included in delivery), Connection for up to seven base stations via radio, Valve and pump protection function, Integrated system clock, Smart Start function for energy-efficient operation</p>	1 unit	585017	01
	<p>Top-hat rail for mounting the base station in the manifold cabinet Length: approx. 400 mm, packed in carton with 2 screws Only order supplies for "Economy" manifold cabinets!</p> <p>ATTENTION: Please take into account the additional space required in the manifold cabinet (width)!</p>	1 set	902600	01

NOTE





* 5 years system warranty with exclusive use of EMPUR® components:
Manifolds, actuators, room operating units and control terminal strips

Control technology

10.6 Exclusiv radio with Ethernet connection

Item	Item description	PU	Item No.	PG
	<p>Wireless base station 230 V 868 MHz with Ethernet connection RJ45*</p> <p>The central module for all information processing and communication with the system components. In the Ethernet version, the single room control can be controlled additionally via a PC and/or Smartphone and on the Internet. An XML interface is also integrated.</p>			
Ethernet-version	<p>Up to 7 base stations can be linked via radio frequency.</p> <p>Simple, intuitive installation with clamp and plug-in technology, pilot function for heating and cooling via boiler output, central switching via external signal, dew-point monitoring via potential-free contact, integrated pump module including pump protection function, connection for safety temperature limiter, anti-freeze function, emergency operation, monitoring of the floor temperature in combination with the floor sensors, valve protection function at all outputs, for top-hat rail mounting, max. rated load of all actuators 24 W</p>			
	<p>4 zones for: 4 operator units/6 actuators 230 V (zones x number of terminals: 2x2+2x1) Dimensions: 225 x 52 x 75 mm</p>	1 unit	585011	01
	<p>8 zones for: 8 operator units/12 actuators 230 V (zones x number of terminals: 4x2+4x1) Dimensions: 290 x 52 x 75 mm</p>	1 unit	585012	01
	<p>12 zones for: 12 operator units/18 actuators 230 V (zones x number of terminals: 6x2+6x1) Dimensions: 355 x 52 x 75 mm</p>	1 unit	585013	01
	<p>Top-hat rail for mounting the base station in the manifold cabinet Length: approx. 400 mm, packed in carton with 2 screws Only order supplies for "Economy" manifold cabinets!</p> <p>ATTENTION: Please take into account the additional space required in the manifold cabinet (width)!</p>	1 set	902600	01

NOTE * 5 years system warranty with exclusive use of EMPUR® components:
Manifolds, actuators, room operating units and control terminal strips

Item	Item description	PU	Item No.	PG
	<p>868 MHz wireless room control unit with display* for wall and flush-mounted box assembly with large and clear LC display (60 x 40 mm) from scratchproof plastic, continuous display of room temperature, system time and operating status, limitation of the adjustment range of the room temperature, convenient dial operation, turn-push mechanism with precise, dynamic setting</p> <p>Adjustment range: 5-30 °C Dimensions: 86 x 86 x 26 mm Battery operation (2 x AAA 1.5 V) Colour: casing white, anthracite display</p>	1 unit	585001	01
	<p>Analogue 868 MHz wireless room control unit without display* for wall and flush-mounted box mounting convenient dial operation with 1/4-degree soft setting, Patented target value comparison</p> <p>Adjustment range: 10-28 °C Dimensions: 86 x 86 x 26 mm Battery operation (2 x AAA 1.5 V) Colour: casing white</p>	1 unit	585002	01
	<p>868 MHz radio room sensor* (authorities model) for wall-mounted and flush-mounted box assembly with hidden controls for use in public areas</p> <p>Adjustment range: 5-30 °C Dimensions: 86 x 86 x 26 mm Battery operation (2 x AAA, 1.5 V) Colour: casing white</p>	1 unit	585003	01
	<p>Cover frame, white Dimensions 94 x 94 mm, for all room control units 86 x 86 mm, for wall mounting under the room control unit</p>	1 unit	572890	01

NEW

NOTE

* 5 years system warranty with exclusive use of EMPUR® components:
Manifolds, actuators, room operating units and control terminal strips









Control technology

10.8 Exclusiv BUS with Ethernet connection

Item	Item description	PU	Item No.	PG
	<p>Base station BUS 24 V with Ethernet connection RJ45*</p> <p>The central module for all information processing and communication with the system components. In the Ethernet version, the single room control can be controlled additionally via a PC and/or Smartphone and on the Internet. An XML interface is also integrated.</p>			
Ethernet version	<p>Up to seven base stations can be linked to one another via a 3-way BUS connection. Simple, intuitive installation with clamp and plug-in technology, pilot function for heating and cooling via boiler output, central switching via external signal, dew-point monitoring via potential-free contact, integrated pump module including pump protection function, connection for safety temperature limiter, anti-freeze function, emergency operation, monitoring of the floor temperature in combination with the floor sensors, Valve protection function at all outputs, for top-hat rail mounting, max. rated load of all actuators 24 W</p>			
BUS version wired	<p>8 zones for: 8 operator units/12 actuators 24 V (zones x number of terminals: 4x2+4x1) Dimensions: 370 x 52 x 75 mm Including 24 V system transformer with mains plug</p>	1 unit	575042	01
	<p>Room control unit BUS with display*</p> <p>for wall and flush-mounted box assembly with large and clear LC display (60 x 40 mm) from scratchproof plastic, continuous display of room temperature, system time and operating status, limitation of the adjustment range of the room temperature, convenient dial operation, turn-push mechanism with precise, dynamic setting Adjustment range: 5-30 °C Dimensions: 86 x 86 x 26 mm Battery operation (2 x AAA 1.5 V) Colour: casing white, anthracite display</p>			
BUS version wired	<p>Two-wire bus connection, reverse polarity protected, for power supply and display backlighting</p>	1 unit	575001	01
	<p>Room control unit BUS analogue without display*</p> <p>for wall and flush-mounted box mounting convenient dial operation with 1/4-degree soft setting, patented target value comparison Adjustment range: 10-28 °C Dimensions: 86 x 86 x 26 mm Battery operation (2 x AAA 1.5 V) Colour: casing white</p>			
BUS version wired	<p>Two-wire bus connection, reverse polarity protected, for power supply</p>	1 unit	575002	01
	<p>Room sensor BUS* (authorities' model)</p> <p>for wall-mounted and flush-mounted box assembly with hidden controls for use in public areas Adjustment range: 5-30 °C, Dimensions: 86 x 86 x 26 mm Battery operation (2 x AAA, 1.5 V), Colour: casing white</p>	1 unit	575003	01
	<p>Cover frame, white</p> <p>Dimensions 94 x 94 mm, for all room control units 86 x 86 mm, for wall mounting under the room control unit</p>	1 unit	572890	01

NEW

10.9 Accessories for Standard plus H/C, radio, Exclusiv radio and BUS

Item	Item description	PU	Item No.	PG
	Humidity monitoring with internal sensor* serves the purpose within a surface heating/cooling system of monitoring the dew point. It detects any condensation on the connection pipe and switches off the cooling mode of the system to protect the building, until no condensation can be discerned. Power supply (24V AC/DC) via base station BUS (Observe the wiring)	1 unit	585020	01
	Humidity monitoring with external sensor, 1 m cable length*	1 unit	585021	01
	Repeater with power adapter, 1.5 m cable length* is used to extend the radio range between the base station and room control units Range \$ 25 m in buildings Power supply 5 V via power adapter	1 unit	585022	01
	Active external antenna, with connecting cable 5 m* is used to extend the radio range of the base station Range \$ 25 m in buildings Power supply by base station	1 unit	585023	01
Attention: Only use the supplied 5 m antenna connection cable!				
	Dew point monitor 230 V, 50-60 Hz, IP20/0 Power 1 VA, for external sensor 12 V	1 unit	560301	01
Only functional in combination with dew point sensor type 2 or type 3! Please observe the installation instructions!				
	Dew point sensor type 2 for dew point monitor 230 V (560301) incl. 10 m cabel, with supply air duct for humidity detection	1 unit	560302	01
	Dew point sensor type 2 for dew point monitor 230 V (560301) incl. 10 m cabel, for pipe mounting	1 unit	560303	01
	Top-hat rail for mounting the base station in the manifold cabinet Length: approx. 400 mm, packed in carton with 2 screws Only order supplies for "Economy" manifold cabinets!	1 set	902600	01
ATTENTION: Please take into account the additional space required in the manifold cabinet (width)!				

NOTE

* 5 years system warranty with exclusive use of EMPUR® components:
Manifolds, actuators, room operating units and control terminal strips

Flat transfer station

11.1 System

NEW



Comfort and hygienic tap water

Energy efficiency is a high priority for builders, whether for new build or renovation. Reducing energy requirements and compliance with statutory regulations are matters of far-reaching importance. Decentralized heating systems reduce heat losses and heating costs, while also increasing comfort and the hygiene of tap water.

Tenants and property owners both want maximum comfort from their heating system at the lowest possible cost. They are less concerned at first about the source of energy used or how the system works.

A flat transfer station regulates the amount of heat supplied for space and water heating to each apartment of a multi-apartment block. These stations can be used in new build but can also be employed in the modernisation of older buildings.

Flat transfer stations for direct, decentralised heating operate on the heating side **with no system separation**. The primary energy carrier flows directly into the unit from the supply network. This is where the control components are employed to obtain the required temperature. Thus, **the tap water is heated on a continuous flow basis and is only provided when it is actually required and used.**

Provided that they are carefully designed, planned and installed, these systems **do not require regular legionella inspections** as are prescribed for central hot water systems by the Ordinance on water for human consumption (Trinkwasserordnung).

Decentralised continuous flow water heater

- Hydraulic unit for decentralised hot water supply
- For direct connection to an EMPUR® floor heating distributor with up to 12 heating circuits
- Central installation location in the dwelling, usually in the bathroom or corridor area, in compliance with Guideline 551 (the 3-litre rule) of the German gas and water association DVGW is recommended
- With built-in adapters for the incoming cold water meter and the heat flow meter to allow easy calculation for each unit

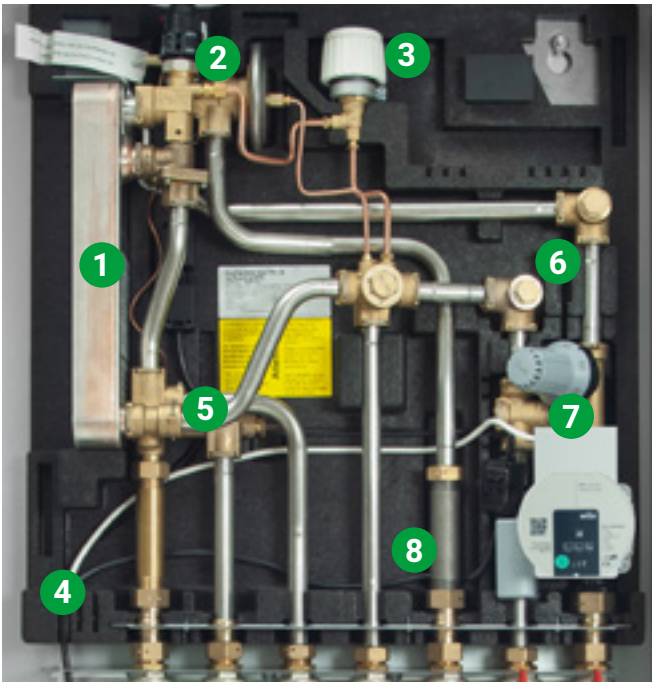

The built-in components make up the overall quality of the home station. The components coordinated for the specific functions in the basic version guarantee safe and reliable operation.

The most important components of our flat transfer station

- 1** Stainless steel **heat exchanger** for energy-efficient flow-through drinking water heating (fresh water system)
- 2** **Combination regulators** – differential pressure and flow regulator, zone valve, thermostat and deaerator in one unit
- 3** **Summer bypass** for fast heating of drinking water, even outside the heating season
- 4** **Heat-insulated** rear panel with insulation hood for lowest radiation losses
- 5** Internal pipe connections in the new **Click-fit technology**, tightness even without tightening
- 6** **Radiator connection** – high-temperature circuit for bathroom radiators
- 7** **Fixed valve control set** – addition control including safety temperature monitor and circulation pump for surface heaters, thermostatic sensor element with feed thermostat, control range 15-50°C
- 8** **Fittings** (3/4" x 110 mm) for heat and cold water meters

Heat exchanger

What is decisive for the energy efficiency of freshwater systems in flat stations is a low-return temperature with simultaneous provision of the required amount of hot water/pouring capacity.

Within the heat exchanger, the heating medium and the drinking water flow past each other based on the counter-current principle.

The hot water temperature is thus substantially determined by the available primary-side temperature of the heating medium. Innovative plate pressing and optimised flow geometry for efficient heat transfer with low pressure loss form the basis for the economical operation of the entire system.

If the water quality is unknown, we recommend the use of a stainless steel brazed heat exchanger.

If the home flat transfer is used with copper-brazed heat exchangers, its suitability with regard to the Water quality to be checked in advance by the system planner or installer!

When closing a water fitting, pressure shocks can occur. Since pressure surges can have an effect on the service life of the heat exchangers, we recommend the on-site installation of a water shock absorber, especially when using stainless steel brazed heat exchangers!

NOTE

The connection option for the circulation is pre-assembled at the factory, so please specify it when ordering! An on-site drain for the safety valve on the circulation set is required! For use of flat stations with a circulation set, the flush-mounted manifold cabinet with 850 mm width should be used.

Flat transfer station

11.3 Basic version of complete station with brass manifold, version 2.0

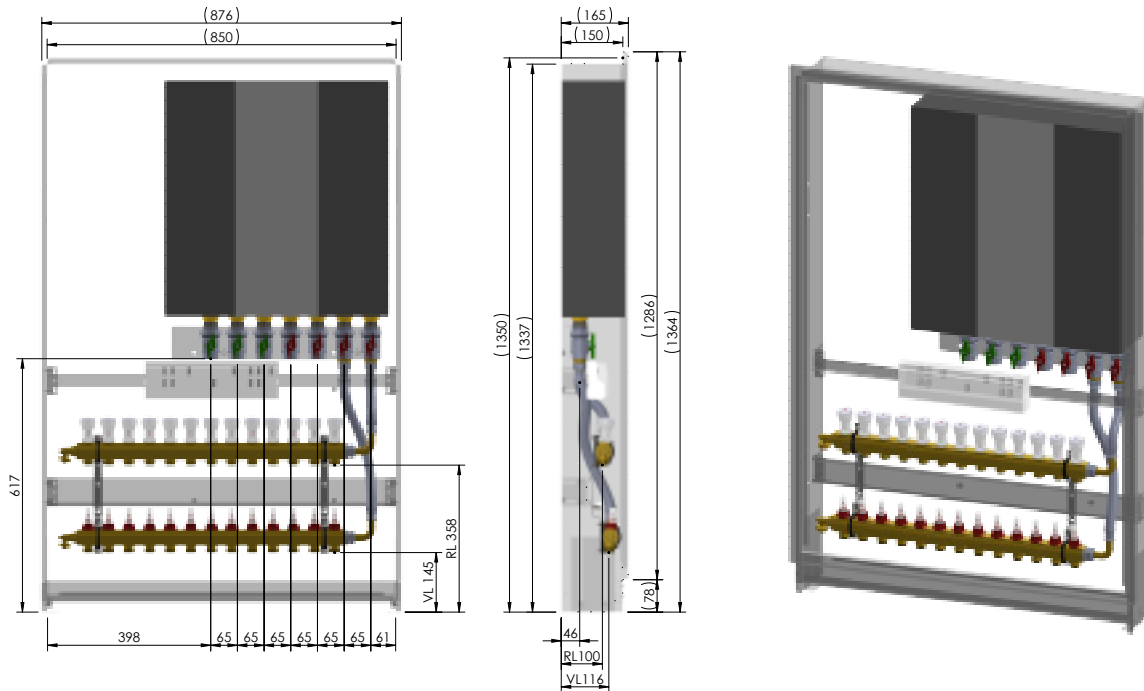

Basic version consisting of:

- Flat transfer station incl. copper-brazed 37 kW stainless steel heat exchanger, summer bypass, thermal insulation, radiator connection, combi controller, without circulation set, in the flush-mounted manifold cabinet 610 mm (or 850 mm from 10 outlets) on mounting rail with 7 shut-off ball valves pre-assembled in the manifold cabinet, incl. piping (supply/return) to the manifold
- Control terminal strip 230 V with pump logic for 6 heating zones/max. 15 actuators pre-assembled on top-hat rail and corresponding number of actuators 230 V assembled and prewired
- Brass manifold, version 2.0 (up to max. 13 outlets) pre-assembled on manifold mounting rail

Configuration basic version (brass) Item 280064

Item description	Manifold outlets	PU	Item No.	PG
HCM-D 5, HE 37kW Cu, FM610, RTS230-HK6/15, ACT	5	1 unit	ÜMS05WT2K16SB20UP6	07
HCM-D 6, HE 37kW Cu, FM610, RTS230-HK6/15, ACT	6	1 unit	ÜMS06WT2K16SB20UP6	07
HCM-D 7, HE 37kW Cu, FM610, RTS230-HK6/15, ACT	7	1 unit	ÜMS07WT2K16SB20UP6	07
HCM-D 8, HE 37kW Cu, FM610, RTS230-HK6/15, ACT	8	1 unit	ÜMS08WT2K16SB20UP6	07
HCM-D 9, HE 37kW Cu, FM610, RTS230-HK6/15, ACT	9	1 unit	ÜMS09WT2K16SB20UP6	07

A cabinet width of 850 mm is required for 10 manifold outlets and more!

HCM-D 10, HE 37kW Cu, FM850 , RTS230-HK6/15, ACT	10	1 unit	ÜMS10WT2K16SB20UP8	07
HCM-D 11, HE 37kW Cu, FM850 , RTS230-HK6/15, ACT	11	1 unit	ÜMS11WT2K16SB20UP8	07
HCM-D 12, HE 37kW Cu, FM850 , RTS230-HK6/15, ACT	12	1 unit	ÜMS12WT2K16SB20UP8	07
HCM-D 13, HE 37kW Cu, FM850 , RTS230-HK6/15, ACT	13	1 unit	ÜMS13WT2K16SB20UP8	07

HE = heat exchanger RTS = regulator terminal strip ACT = actuator

NOTE

Additional price items, performance values and notes for complete station can be found on page 89. We are happy to offer you the commissioning (EM999026) of the heat transfer station on request.

11.3 Basic version of complete station with stainless steel manifold, series 03

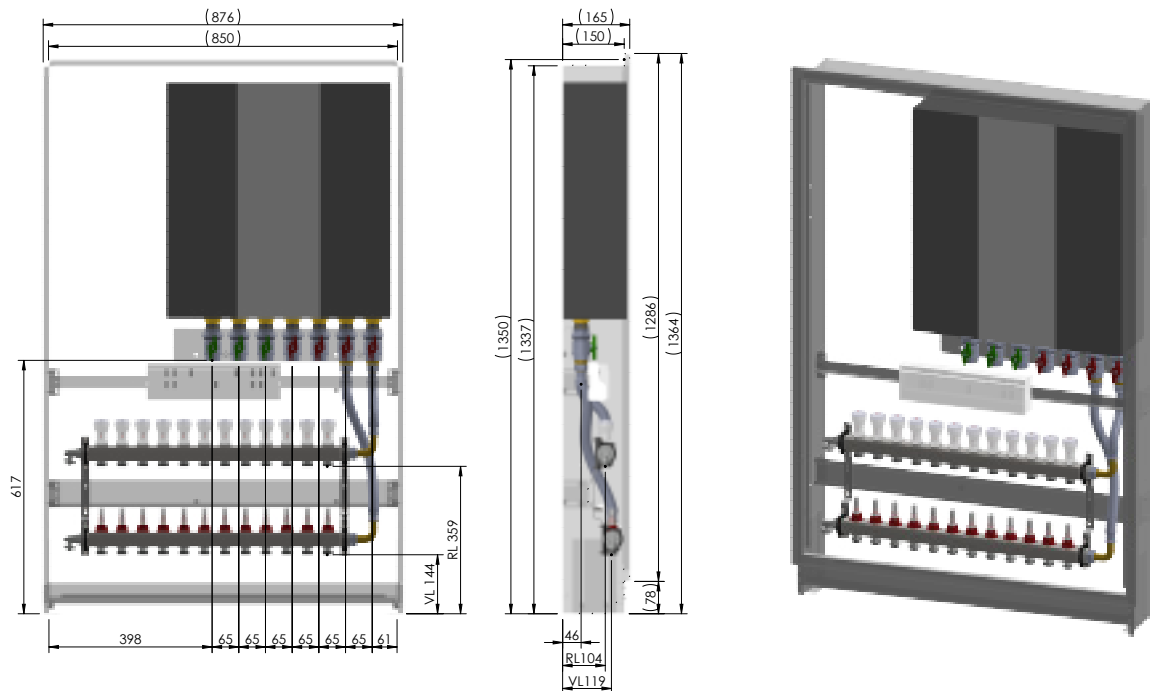

Basic version consisting of:

- Flat transfer station incl. copper-brazed 37 kW stainless steel heat exchanger, summer bypass, thermal insulation, radiator connection, combi controller, without circulation set, in the flush-mounted manifold cabinet 610 mm (or 850 mm from 9 outlets) on mounting rail with 7 shut-off ball valves pre-assembled in the manifold cabinet, incl. piping (supply/return) to the manifold
- Control terminal strip 230 V with pump logic for 6 heating zones/max. 15 actuators pre-assembled on top-hat rail and corresponding number of actuators 230 V assembled and prewired
- Stainless steel manifold, series 03 (up to max. 12 outlets) pre-assembled on manifold mounting rail

Configuration basic version (stainless steel) Item 280065

Item description	Manifold outlets	PU	Item No.	PG
HCM-D 5, HE 37kW Cu, FM610, RTS230-HK6/15, ACT	5	1 unit	ÜES05WT2K16SB20UP6	07
HCM-D 6, HE 37kW Cu, FM610, RTS230-HK6/15, ACT	6	1 unit	ÜES06WT2K16SB20UP6	07
HCM-D 7, HE 37kW Cu, FM610, RTS230-HK6/15, ACT	7	1 unit	ÜES07WT2K16SB20UP6	07
HCM-D 8, HE 37kW Cu, FM610, RTS230-HK6/15, ACT	8	1 unit	ÜES08WT2K16SB20UP6	07
A cabinet width of 850 mm is required for 9 manifold outlets and more!				
HCM-D 9, HE 37kW Cu, FM850 , RTS230-HK6/15, ACT	9	1 unit	ÜES09WT2K16SB20UP8	07
HCM-D 10, HE 37kW Cu, FM850 , RTS230-HK6/15, ACT	10	1 unit	ÜES10WT2K16SB20UP8	07
HCM-D 11, HE 37kW Cu, FM850 , RTS230-HK6/15, ACT	11	1 unit	ÜES11WT2K16SB20UP8	07
HCM-D 12, HE 37kW Cu, FM850 , RTS230-HK6/15, ACT	12	1 unit	ÜES12WT2K16SB20UP8	07

HE = heat exchanger RTS = regulator terminal strip ACT = actuator

NOTE Additional price items, performance values and notes for complete station can be found on page 89. We are happy to offer you the commissioning (EM999026) of the heat transfer station on request.

Flat transfer station

11.3 Basic version of complete station with stainless steel manifold, series 03 Balance

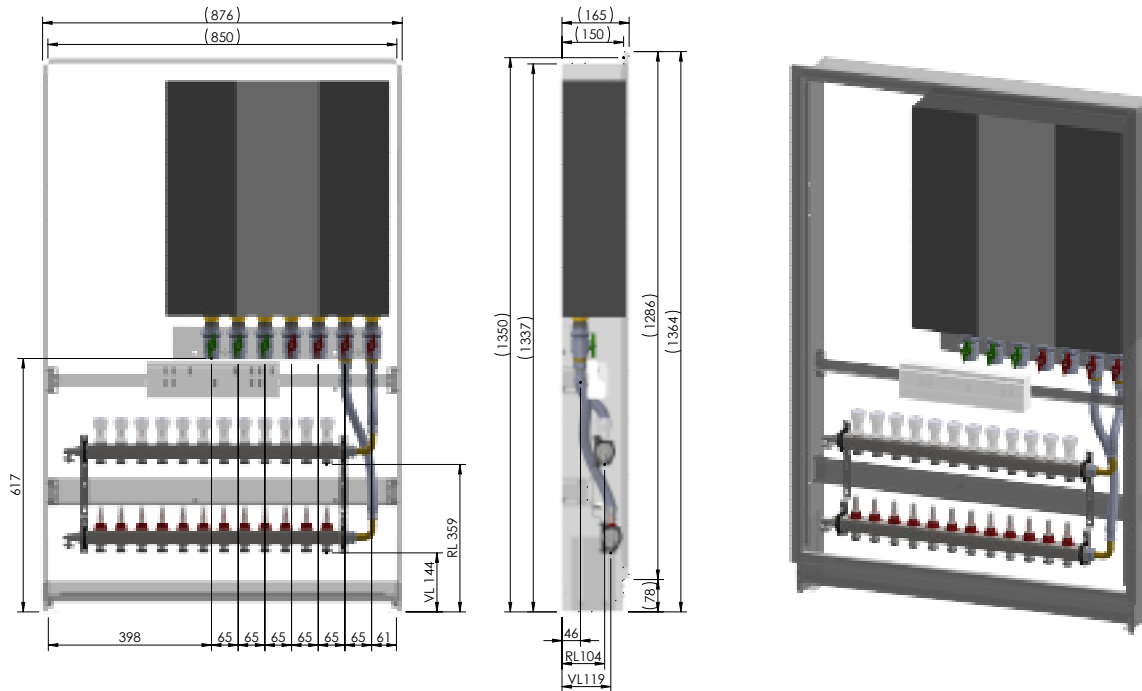

Basic version consisting of:

- Flat transfer station incl. copper-brazed 37 kW stainless steel heat exchanger, summer bypass, thermal insulation, radiator connection, combi controller, without circulation set, in the flush-mounted manifold cabinet 610 mm (or 850 mm from 9 outlets) on mounting rail with 7 shut-off ball valves pre-assembled in the manifold cabinet, incl. piping (supply/return) to the manifold
- Control terminal strip 230 V with pump logic for 6 heating zones/max. 15 actuators pre-assembled on top-hat rail and corresponding number of actuators 230 V assembled and prewired
- Stainless steel manifold, series 03 Balance (up to max. 12 outlets) pre-assembled on manifold mounting rail

Configuration basic version (stainless steel Balance) Item 280068

Item description	Manifold outlets	PU	Item No.	PG
HCM-D 5, HE 37kW Cu, FM610, RTS230-HC6/15, ACT	5	1 unit	ÜBE05WT2K16SB20UP6	07
HCM-D 6, HE 37kW Cu, FM610, RTS230-HK6/15, ACT	6	1 unit	ÜBE06WT2K16SB20UP6	07
HCM-D 7, HE 37kW Cu, FM610, RTS230-HK6/15, ACT	7	1 unit	ÜBE07WT2K16SB20UP6	07
HCM-D 8, HE 37kW Cu, FM610, RTS230-HK6/15, ACT	8	1 unit	ÜBE08WT2K16SB20UP6	07
A cabinet width of 850 mm is required for 9 manifold outlets and more!				
HCM-D 9, HE 37kW Cu, FM850 , RTS230-HK6/15, ACT	9	1 unit	ÜBE09WT2K16SB20UP8	07
HCM-D 10, HE 37kW Cu, FM850 , RTS230-HK6/15, ACT	10	1 unit	ÜBE10WT2K16SB20UP8	07
HCM-D 11, HE 37kW Cu, FM850 , RTS230-HK6/15, ACT	11	1 unit	ÜBE11WT2K16SB20UP8	07
HCM-D 12, HE 37kW Cu, FM850 , RTS230-HK6/15, ACT	12	1 unit	ÜBE12WT2K16SB20UP8	07

HE = heat exchanger RTS = regulator terminal strip ACT = actuator

NOTE Additional price items, performance values and notes for complete station can be found on page 89. We are happy to offer you the commissioning (EM999026) of the heat transfer station on request.

11.3 Basic version of complete station with Geniax brass manifold

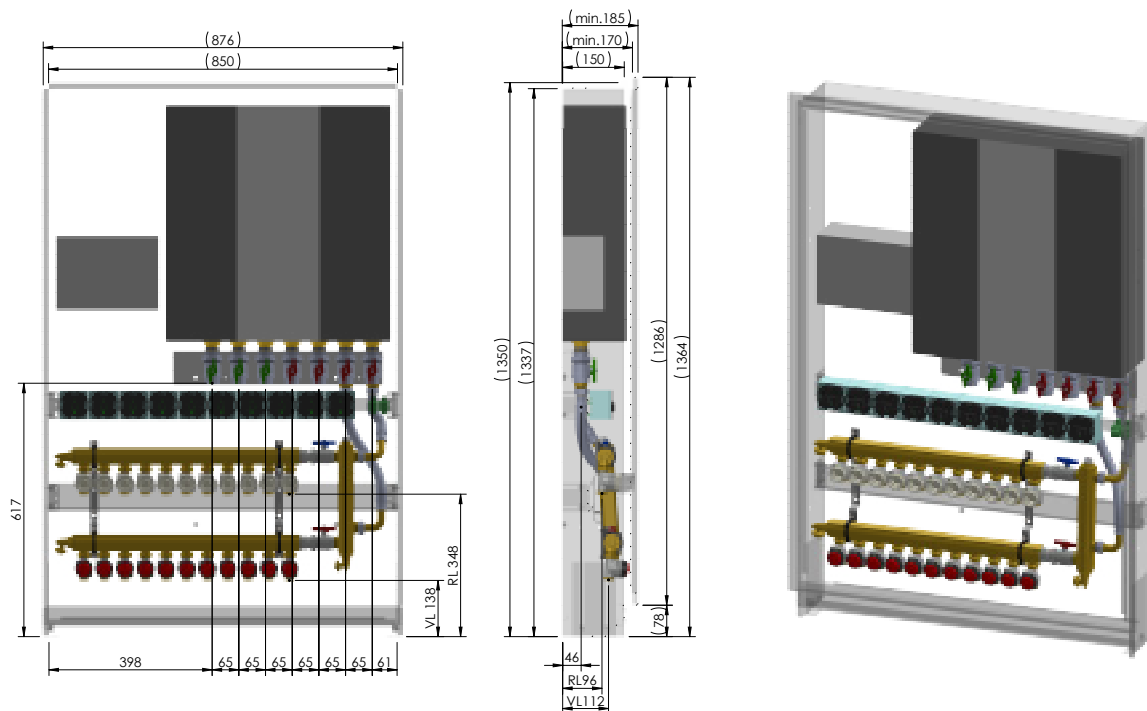

Basic version consisting of:

- **Flat transfer station incl. copper-brazed 37 kW stainless steel heat exchanger**, summer bypass, thermal insulation, radiator connection, combi controller, **without circulation set**, in the **flush-mounted manifold cabinet 850 mm** on mounting rail with 7 shut-off ball valves pre-assembled in the manifold cabinet, incl. piping (supply/return) to the manifold
- **Geniax server with 2.5 A power supply**, flow sensor, actuator 24 V, 0-10 V with power supply 230/24 V continuously regulating for volume flow/flow temperature control, external connections placed on terminal
- **EMPUR® Geniax complete manifold HCM-G, brass** (up to max. 11 outlets) with thermal switch, fully pre-assembled in the flush-mounted manifold cabinet with factory-mounted pump electronics and BUS terminals, Geniax pumps and backflow preventer supplied loose, factory tested and logged

Configuration basic version (Geniax brass) Item 280061

Item description	Manifold outlets	PU	Item No.	PG
HCM-G 5+TS, HE 37kW Cu, FM850, CS 2,5A	5	1 unit	ÜGM05WT2Z5UP8	07
HCM-G 6+TS, HE 37kW Cu, FM850, CS 2,5A	6	1 unit	ÜGM06WT2Z5UP8	07
HCM-G 7+TS, HE 37kW Cu, FM850, CS 2,5A	7	1 unit	ÜGM07WT2Z5UP8	07
HCM-G 8+TS, HE 37kW Cu, FM850, CS 2,5A	8	1 unit	ÜGM08WT2Z5UP8	07
HCM-G 9+TS, HE 37kW Cu, FM850, CS 2,5A	9	1 unit	ÜGM09WT2Z5UP8	07
HCM-G 10+TS, HE 37kW Cu, FM850, CS 2,5A	10	1 unit	ÜGM10WT2Z5UP8	07
HCM-G 11+TS, HE 37kW Cu, FM850, CS 2,5A	11	1 unit	ÜGM11WT2Z5UP8	07

TS = thermoseparator HE = heat exchanger CS = control system

NOTE

Additional price items (only WTI, WT3-7 possible), performance values and notes for complete station can be found on page 89. We are happy to offer you the commissioning (EM999026) of the heat transfer station on request.

Flat transfer station

11.3 Basic version of complete station with Geniax stainless steel manifold

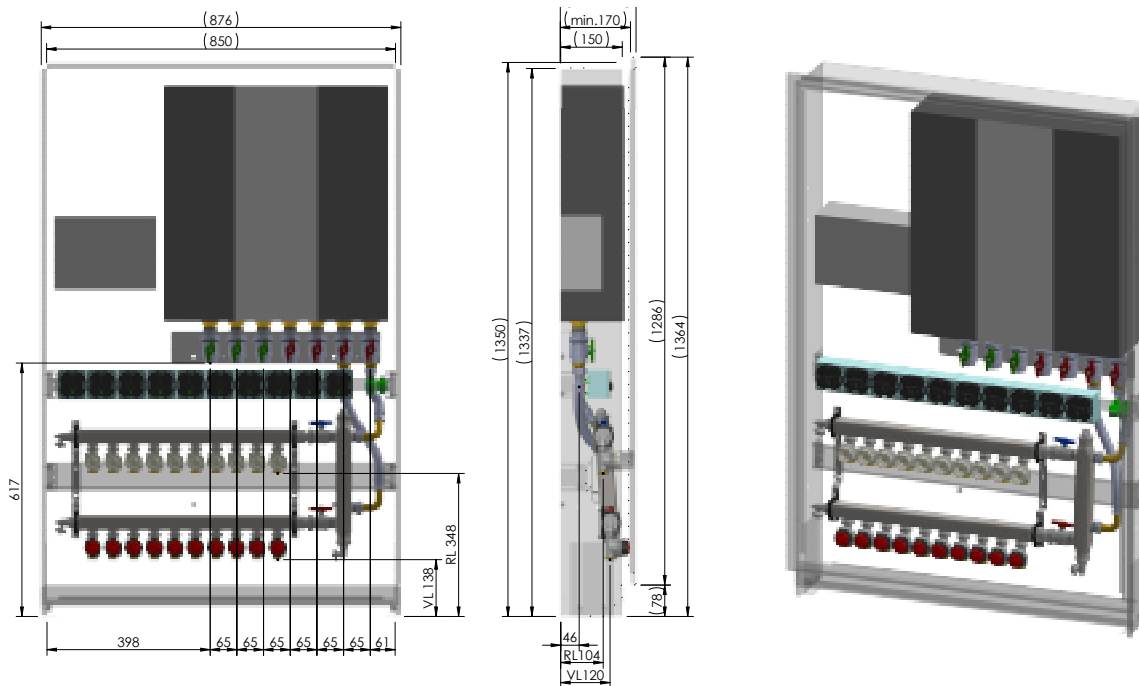

Basic version consisting of:

- **Flat transfer station incl. copper-brazed 37 kW stainless steel heat exchanger**, summer bypass, thermal insulation, radiator connection, combi controller, **without circulation set**, in the **flush-mounted manifold cabinet 850 mm** on mounting rail with 7 shut-off ball valves pre-assembled in the manifold cabinet, incl. piping (supply/return) to the manifold
- **Geniax server with 2.5 A power supply**, flow sensor, actuator 24 V, 0-10 V with power supply 230/24 V continuously regulating for volume flow/flow temperature control, external connections placed on terminal
- **EMPUR® Geniax complete manifold HCM-G, stainless steel** (up to max. 10 outlets) with thermal switch, fully pre-assembled in the flush-mounted manifold cabinet with factory-mounted pump electronics and BUS terminals, Geniax pumps and backflow preventer supplied loose, factory tested and logged

Configuration basic version (Geniax stainless steel) Item 280060

Item description	Manifold outlets	PU	Item No.	PG
HCM-G 5+TS, HE 37kW Cu, FM850, CS 2,5A	5	1 unit	ÜGE05WT2Z5UP8	07
HCM-G 6+TS, HE 37kW Cu, FM850, CS 2,5A	6	1 unit	ÜGE06WT2Z5UP8	07
HCM-G 7+TS, HE 37kW Cu, FM850, CS 2,5A	7	1 unit	ÜGE07WT2Z5UP8	07
HCM-G 8+TS, HE 37kW Cu, FM850, CS 2,5A	8	1 unit	ÜGE08WT2Z5UP8	07
HCM-G 9+TS, HE 37kW Cu, FM850, CS 2,5A	9	1 unit	ÜGE09WT2Z5UP8	07
HCM-G 10+TS, HE 37kW Cu, FM850, CS 2,5A	10	1 unit	ÜGE10WT2Z5UP8	07

TS = thermoseparator HE = heat exchanger CS = control system

NOTE Additional price items (only WTI, WT3-7 possible), performance values and notes for complete station can be found on page 89. We are happy to offer you the commissioning (EM999026) of the heat transfer station on request.

Items available for an additional charge

Items available for an additional charge in combination with basic version complete stations brass manifold, version 2.0, stainless steel manifold series 03, stainless steel manifold series 03 Balance

Item description	PU	Item No.	PG
* Circulation set, pre-assembled consisting of pump, check valve and safety valve	1 unit	WT1	07
* Flush-mounted manifold cabinet 850 mm (instead of 610 mm) always required in combination with circulation set!	1 unit	UP850	07
Control terminal strip with pump logic for 10 heating zones/18 actuators (instead of 6 zones)	1 unit	K11	07
Control terminal strip balance with pump logic for 8 heating zones/17 actuators (instead of 6 zones)	1 unit	K18	07
Actuator with assembly aid "Man Open", normally closed (instead of "Economy" actuator)	1 unit	SB30	07
Controller, weather-controlled (APP operation) with external and forward feed sensor, 3-point actuator, 230 V with adapter	1 unit	Z3	07
230 V room control unit with display, with lowering output and adjustable time program (clock thermostat)	1 unit	Z4	07
* 45 kW heat exchanger capacity, Cu brazed (instead of 37 kW Cu brazed)	1 unit	WT4	07
* 55 kW heat exchanger capacity, Cu brazed (instead of 37 kW Cu brazed)	1 unit	WT6	07
* 37 kW heat exchanger capacity, stainless steel brazed (instead of 37 kW Cu brazed)	1 unit	WT3	07
* 45 kW heat exchanger capacity, stainless steel brazed (instead of 37 kW Cu brazed)	1 unit	WT5	07
* 51 kW heat exchanger capacity, stainless steel brazed (instead of 37 kW Cu brazed)	1 unit	WT7	07



*** Items must be included in the order, as they are pre-assembled at the factory and cannot be retrofitted and converted!**

Item description	PU	Item No.	PG
Commissioning of 1-3 stations	1 unit	EM999026	05
Commissioning of 4-9 stations	1 unit	EM999026	05
Commissioning from 10 stations	1 unit	EM999026	05
Commissioning GeniAx Server	1 unit	572060	05

Performance values drinking water heating/pouring capacity at 10/50°C (10/45°C)

Size/type Heat exchanger	Capacity (kW)	Flow/return (°C) Primary side	Pressure loss (kPa) Primary side (without WMZ)	Flow (l/h) Primary side	Hot water Tap capacity (l/min)
Size 1/Cu or Brazed stainless steel	37 43	65 / 21 65 / 22	23 40	730 850	13,3 15,3 (18,4)
Size 2/Cu or Brazed stainless steel	45 49	65 / 20 65 / 21	22 30	867 950	16,1 17,5 (20,9)
Size 3/Cu brazed	55 38	65 / 16 55 / 21	27 27	950 950	19,4 (22,9) 13,6
Size 3/ Brazed stainless steel	51 34	65 / 19 55 / 14	28 28	950 950	18,3 (22,7) 12,5

NOTE

Delivery time after receipt of order and final technical clarification is six weeks! Item and configuration number must always be specified when ordering! Please note that a special discount applies to the flat transfer stations. Additional control components can be found on page 70 and following pages. To facilitate transport and assembly, as well as to prevent damage and theft during shell construction, the home station can be dismantled. On request, delivery is made in two pre-assembled sub-units.



XXL-Industry and EMPUR® concrete core tempering (CCT)

The XXL-Industry industrial panel heating system and EMPUR® concrete core tempering are **sensible and cost-efficient heating systems for commercial and trade applications**. With these two industrial solutions the pipes (mostly 5-layer pipes) are laid on **reinforcement steel mesh** and attached with **binding wire**. Here, the heating pipes are fixed depending on the application to the bottom, to the middle or to the upper reinforcement.

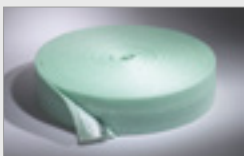
Item	Item description	PU	Item No.	PG
	Bare pipe mat Wire thickness 3 mm, main grid 100 x 100 mm Dimensions 2,100 x 1,200 mm, weight 2.98 kg/unit	1 unit	900302	01
	Wire thickness 3 mm, main grid 150 x 150 mm Dimensions 2,100 x 1,200 mm, weight 2.05 kg/unit	1 unit	900310	01
	XXL-Industry edge insulation strip Special edge insulation strips for industrial panel heating, made of polyethylene with self-adhesive film apron, for structural heights of up to 250 mm Dimension 10 x 250 mm	Ro 50 m	908155	01

12.1 XXL-Industry and EMPUR® concrete core tempering (CCT)

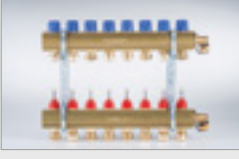
Item	Item description	Heating circuit	Conne- ction	Over- all length	Cabinet width in mm**	Item No.	PG
	Industrial manifold XXL-D for pipe 25 x 2.3*						
	Complete manifold made of brass section pipe 5/4" with integrated valves, 65 mm valve clearance.						
	Return flow valve (top) with blue protection cap.	HCM-D 5	5/4" IG	375	720	270525	01
	EMPUR® actuators can be installed directly instead of the blue protection caps. Feed flow (bottom)	HCM-D 6	5/4" IG	440	920	270625	01
	with controllable and adjustable flow rate indicators (0-8 l/min.). Max. permissible volume flow	HCM-D 7	5/4" IG	505	920	270725	01
	of all heating circuits 3 m³/h. 2 manifold end-	HCM-D 8	5/4" IG	570	920	270825	01
	pieces with reducer for filling, bleeding and	HCM-D 9	5/4" IG	635	1,120	270925	01
	draining, rotating, manifold holder with sound insu-	HCM-D 10	5/4" IG	700	1,120	271025	01
	lation insert. Heating circuit connections for pipe	HCM-D 11	5/4" IG	765	1,120	271125	01
	25 x 2.3 including compression fittings, pre-	HCM-D 12	5/4" IG	830	1,320	271225	01
assembled on the manifold. Packaged in a carton	HCM-D 13	5/4" IG	895	1,320	271325	01	
with identification plates.	HCM-D 14	5/4" IG	960	1,320	271425	01	
	HCM-D 15	5/4" IG	1,025	1,520	271525	01	
	HCM-D 16	5/4" IG	1,090	1,520	271625	01	
	Industrial manifold XXL-D for pipe 20 x 2.0*						
	Complete manifold made of brass section pipe 5/4" with integrated valves, 50 mm valve clearance.						
	Return flow valve (top) with blue protection cap.	HCM-D 5	5/4" IG	315	720	270520	01
	EMPUR® actuators can be installed directly instead of the blue protection cap. Feed flow (bottom)	HCM-D 6	5/4" IG	365	720	270620	01
	with controllable and adjustable flow rate indi-	HCM-D 7	5/4" IG	415	720	270720	01
	cators (0-5 l/min.). Max. permissible volume flow	HCM-D 8	5/4" IG	465	920	270820	01
	of all heating circuits 3 m³/h. 2 manifold end-	HCM-D 9	5/4" IG	515	920	270920	01
	pieces with reducer for filling, bleeding and	HCM-D 10	5/4" IG	565	920	271020	01
	draining, rotating, manifold holder with sound insu-	HCM-D 11	5/4" IG	615	920	271120	01
	lation insert, Heating circuit connections for pipe	HCM-D 12	5/4" IG	665	1,120	271220	01
20 x 2.0 including compression fittings, packed in	HCM-D 13	5/4" IG	715	1,120	271320	01	
bag and enclosed. All packaged in a carton and	HCM-D 14	5/4" IG	765	1,120	271420	01	
with identification plates.	HCM-D 15	5/4" IG	815	1,120	271520	01	
	HCM-D 16	5/4" IG	865	1,320	271620	01	

Assignment of manifold 5/4" with 50 mm valve clearance in combination with manifold cabinets „Top Standard plus“ and „Exclusiv plus“

Heating circuits	KH passageway	KH-90°	WMZ-horizontal	WMZ-vertical
5/6	720 mm	720 mm	920 mm	920 mm
7	720 mm	920 mm	920 mm	920 mm
8	920 mm	920 mm	1,120 mm	920 mm
9/10	920 mm	920 mm	1,120 mm	1,120 mm
11	920 mm	1,120 mm	1,120 mm	1,120 mm
12	1,120 mm	1,120 mm	1,320 mm	1,120 mm
13/14	1,120 mm	1,120 mm	1,320 mm	1,320 mm
15	1,120 mm	1,320 mm	1,320 mm	1,320 mm
16	1,320 mm	1,320 mm	1,520 mm	1,320 mm

NOTE

* 5 years system warranty with exclusive use of EMPUR® components:





Manifolds, actuators, room operating units and control terminal strips

** Cabinet size for manifolds with connection set passageway 5/4" (item no. 290114), suitable manifold cabinets: "Top Standard-plus" and "Exclusiv-plus" see page 50/51. KLIMAPEX® heating pipes see page 6-8. The water quality requirements according to VDI 2035 must be adhered to.





Industry solutions

12.2 System accessories

XXL-Industry

Item	Item description	PU	Item No.	PG
	Mounting clips			
	made of PP copolymer, without sharp edges, can be fitted to reinforcement mats installed on site, individual laying clearances possible			
	for pipe Ø 20 x 2.0 mm, universal	Bag 100 units	912000	01
	for pipe Ø 25 x 2.3 mm, 6 mm wire thickness	Bag 100 units	912506	01
	for pipe Ø 25 x 2.3 mm, 8 mm wire thickness	Bag 100 units	912508	01
	Pipe holder for industrial panel heating			
	4.8 x 170 mm	100 units	914817	01
	7.8 x 290 mm	100 units	914818	01
	Mat connector/Pipe connector			
	Wire loops to connect the reinforcement mats installed on site and for fixing the expansion joint protection pipes in the expansion joint area, simple assembly with EMPUR® drill tool for fast and efficient installation			
	120 mm	Bag 1,000 units	900045	01
	180 mm	Bag 1,000 units	900046	01
	Drill tool			
	Drill tool for the quick and easy assembly of EMPUR® pipe connector on reinforcement mats laid on site	1 unit	990046	02

XXL-Industry and EMPUR® concrete core tempering (CCT)

Item	Item description	PU	Item No.	PG
	Clip rail for KLIMAPEX® heating pipes for fast and efficient laying of industrial panel heating, for pipe Ø 20 mm, length 2 m, with adhesive strips for pipe spacing in 50 mm grid	1 unit	912002	01
	for pipe Ø 25 mm, length 2 m, with adhesive strips for pipe spacing in 100 mm grid	1 unit	912502	01
	Angle brace 90°, open for redirecting pipes in the manifold and floor zone, for pipes up to max. Ø 20 mm	Btl 10 units	902020	01
	for pipes up to max. Ø 25 mm	Btl 10 units	902426	01
	Expansion joint protective pipe for pipes up to Ø 25 mm, length 400 mm, slotted outside Ø approx. 35 mm	Btl 5 units	918410	01
	Expansion joint protective pipe on roll for pipes up to Ø 25 mm, length 25 m, unslotted	1 Ro	918510	01
	for pipes up to Ø 25 mm, length 25 m, slotted outside Ø approx. 35 mm	1 Ro	918610	01
	Zone valve Zone valve with screwed connection and actuator for zone-by-zone control via room thermostat, dimensions: 1" ET/1" IT, Length: 125 mm, with reducer 5/4" ET-1" IT, kv: 5.1 m³/h	1 unit	520026	01
	Binding machine „Exclusiv“ with new designed tongs for efficient mounting of KLIMAPEX® heating pipes on reinforcement mats or heating grids installed on site, span Ø 12-40 mm, wire thickness: 0.8 mm, less than 1 seconds per binding with 3 coils per binding, wire roll for approx. 120 bindings, strength and wire length of the binding is adjustable, about 2,600 bindings per battery charge, ergonomically-shaped tool for gentle hand and muscle hand-ling, binding machines in practical plastic box with two batteries and a 230 volt charger and two rolls of wire weight: 2.4 kg, dimensions: 305 x 105 x 290 mm	1 unit	990050	02
	Binding machine as a loan unit for a fee of 28€ per day plus VAT. To order through wholesale. After returning and checking, the credit minus rental fee is issued to the wholesale. If the inspection shows that the machine has been returned to us defective or incomplete, the repair or the missing material will also be deducted from the credit.	1 unit	990052	02
	Wire reel for binding machine Wire thickness: 0.8 mm, for approx. 120 bindings	1 Ro	990051	02

Sports floor

13.1 EMPUR® sports floor heating







EMPUR® sports floor heating

With its flexible surface heating systems, EMPUR® also provides special **individual solutions for sports halls and sports areas**. The combination of low system temperatures and modern heat-generation systems makes sports facilities comfortable. The following versions are available, depending on functionality and use:

Area-elastic sports floors – Heating pipes are laid on the EMPUR® system insulation in the air space, application of the stapler system, the “Optimal II” dry construction system or the clip rail system

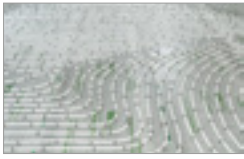
Point-elastic sports floors – the pipes are laid on the EMPUR® system insulation. Subsequently a conventional cement or anhydride layer must be applied

Item	Item description	PU	Item No.	PG
	Clip rail For KLIMAPEX® heating pipes for fast and efficient laying of sports floor heating for pipe Ø 20, length 2 m, with adhesive strips for pipe spacing in 50 mm grid	1 unit	912002	01
	for pipe Ø 25, length 2 m, with adhesive strips for pipe spacing in 100 mm grid	1 unit	912502	01
	Point-elastic sports floors Heating pipes are laid on the EMPUR® system insulation in the air space, application of the stapler system (see page 10-12), the “Optimal II” dry construction system (see page from 23/24) or the clip rail system			
	Point-elastic sports floors The pipes are laid on the EMPUR® system insulation. Subsequently a conventional cement or anhydride layer must be applied, system components (see page 10-12)			
	Pipe guide rail for area-elastic sports floors for installation of pipelines on the subfloor construction design for pipe 20 x 2.0 mm for pipe 25 x 2.3 mm	1 unit 1 unit	914920 914925	01 01

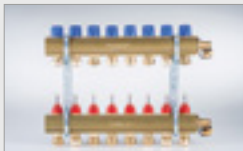
Item	Item description	Heating circuit	Conne- ction	Over- all length	Cabinet width in mm**	Item No.	PG	
	Industrial manifold XXL-D for pipe 25 x 2.3* Complete manifold made of brass section pipe 5/4" with integrated valves, 65 mm valve clearance. Return flow valve (top) with blue protection cap. EMPUR® actuators can be installed directly instead of the blue protection caps. Feed flow (bottom) with controllable and adjustable flow rate indicators (0-8 l/min.). Max. permissible volume flow of all heating circuits 3 m³/h. 2 manifold end-pieces with reducer for filling, bleeding and draining, rotating, manifold holder with sound insulation insert. Heating circuit connections for pipe 25 x 2.3 including compression fittings, pre-assembled on the manifold. Packaged in a carton with identification plates.	HCM-D 5	5/4" IG	375	720	270525	01	
	HCM-D 6	5/4" IG	440	920	270625	01		
	HCM-D 7	5/4" IG	505	920	270725	01		
	HCM-D 8	5/4" IG	570	920	270825	01		
	HCM-D 9	5/4" IG	635	1,120	270925	01		
	HCM-D 10	5/4" IG	700	1,120	271025	01		
	HCM-D 11	5/4" IG	765	1,120	271125	01		
	HCM-D 12	5/4" IG	830	1,320	271225	01		
	HCM-D 13	5/4" IG	895	1,320	271325	01		
	HCM-D 14	5/4" IG	960	1,320	271425	01		
	HCM-D 15	5/4" IG	1,025	1,520	271525	01		
	HCM-D 16	5/4" IG	1,090	1,520	271625	01		
		Industrial manifold XXL-D for pipe 20 x 2.0* Complete manifold made of brass section pipe 5/4" with integrated valves, 50 mm valve clearance. Return flow valve (top) with blue protection cap. EMPUR® actuators can be installed directly instead of the blue protection cap. Feed flow (bottom) with controllable and adjustable flow rate indicators (0-5 l/min.). Max. permissible volume flow of all heating circuits 3 m³/h. 2 manifold end-pieces with reducer for filling, bleeding and draining, rotating, manifold holder with sound insulation insert, Heating circuit connections for pipe 20 x 2.0 including compression fittings, packed in bag and enclosed. All packaged in a carton and with identification plates.	HCM-D 5	5/4" IG	315	720	270520	01
		HCM-D 6	5/4" IG	365	720	270620	01	
		HCM-D 7	5/4" IG	415	720	270720	01	
		HCM-D 8	5/4" IG	465	920	270820	01	
HCM-D 9		5/4" IG	515	920	270920	01		
HCM-D 10		5/4" IG	565	920	271020	01		
HCM-D 11		5/4" IG	615	920	271120	01		
HCM-D 12		5/4" IG	665	1,120	271220	01		
HCM-D 13		5/4" IG	715	1,120	271320	01		
HCM-D 14		5/4" IG	765	1,120	271420	01		
HCM-D 15		5/4" IG	815	1,120	271520	01		
HCM-D 16		5/4" IG	865	1,320	271620	01		

Assignment of manifold 5/4" with 50 mm valve clearance in combination with manifold cabinets „Top Standard plus“ and „Exclusiv plus“

Heating circuits	KH passageway	KH-90°	WMZ-horizontal	WMZ-vertical
5/6	720 mm	720 mm	920 mm	920 mm
7	720 mm	920 mm	920 mm	920 mm
8	920 mm	920 mm	1,120 mm	920 mm
9/10	920 mm	920 mm	1,120 mm	1,120 mm
11	920 mm	1,120 mm	1,120 mm	1,120 mm
12	1,120 mm	1,120 mm	1,320 mm	1,120 mm
13/14	1,120 mm	1,120 mm	1,320 mm	1,320 mm
15	1,120 mm	1,320 mm	1,320 mm	1,320 mm
16	1,320 mm	1,320 mm	1,520 mm	1,320 mm

NOTE

* 5 years system warranty with exclusive use of EMPUR® components:

Manifolds, actuators, room operating units and control terminal strips

** Cabinet size for manifolds with connection set Passageway 5/4" (item no. 290114), suitable manifold cabinets: "Top Standard-plus" and "Exclusiv-plus" see page 50/51. KLIMAPEX® heating pipes see page 6-8. The water quality requirements according to VDI 2035 must be adhered to.



The epoint charging system

THE CHARGING INFRASTRUCTURE HARDWARE



Our hardware solutions meet the highest demands, and we offer **a suitable solution for every application**, whether for use in the private sector or for parking lots, car parks, residential complexes, hotels, commercial enterprises or public buildings. All systems are manufactured to the highest industry standards.





The **epoint wall boxes** are a convenient solution for home use or parking spaces. They are suitable for indoor and outdoor wall mounting or can be mounted on a stand. They are suitable for charging all common electric cars and enable much faster charging than a conventional socket.



Our high-quality **epoint charging stations** are custom-made in Germany and can be used for public areas and **charging capacity billing** as they are **legally compliant with calibration requirements**. Thanks to the high-quality powder coating, almost any design can be implemented. Particular attention is paid to user safety. We work according to the sustainability principle and guarantee longevity and ease of maintenance of the **epoint** charging points.

Customer-specific advice is a matter of course for us, as is full service throughout Germany and support in applying for available subsidies.

The epoint charging systems impresses:

- Manufacturing of all **epoint** components according to the highest industry standards
- Ability to take advantage of leaps in technology through the easy replacement of individual hardware components
- Sustainable system – defective individual components within the charging points can be replaced, no complete disposal is required
- Reduction of maintenance costs – quick and easy replacement of a charging point, even by “non-experts”
- Longevity – after expiry of legal conformance with calibration requirements, nothing stands in the way of a meter change

Item	Item description	PU	Item No.	PG
	<p>Wall box epoint11 up to 11 kW charging power, compact AC wall box made of plastic (black) for wall or stand mounting (stand not included) outdoors or indoors, charging connector type 2, cable length 4 m, with integrated DC residual current detection and protection against overload or electric shock</p> <p>Power supply: 3P+N+PE Rated/output voltage: 400 V AC Rated power: 11 kW, rated current: 16A Residual current circuit breaker type A, FI/LS C32A, <30mA An additional type A (30 mA AC) ground fault circuit interrupter is required. protection class IP65, frequency: 50/60 Hz, operating temperature: -30 °C to +50 °C Control and communication: 2x key cards RFID, OCPP 1.6 JSON, WLAN CE marking Product dimensions: (HxWxD) 325 x 181 x 87 mm Dimensions: (HxWxD) 434 x 324 x 210 mm Net weight: 3.2 kg, gross weight: 4.0 kg, packaged in carton FOR USE IN: Private households</p>	1 unit	99515001	08
	<p>Wall box epoint WB 2.0 up to 22 kW charging power, sturdy and durable AC wall box made of powder-coated steel (in desired RAL colour), for wall mounting outdoors or indoors, charging type 2 connector, with integrated DC residual current detection and protection against overload or electric shock</p> <p>Legally calibration-compliant billing of charging power to users via epark- station software system, used via app</p> <p>Power supply: 3P+N+PE, rated/output power: 400 V AC Rated power: 22 kW, nominal current: 32 A Residual current circuit breaker type A, FI/LS C32A, <30mA, protection class IP65, frequency: 50 Hz, Operating temperature: -30 °C to +50 °C Control and communication (mobile radio interface): 2.5 G (GPRS), 3G (UMTS with HSPA), Ethernet interface: 1x RJ-45 connectors, CE marking Product dimensions: (HxWxD) 400 x 300 x 155 mm Net weight: 15.0 kg, packaged in carton FOR USE IN: Private households, public sector</p>	1 unit	99515003	08
	<p>Wall box epoint WB 2.1 up to 22 kW charging power, with external plug box (flush-mounted), for separate mounting of charging electronics and charging plug, display of the charging status in plug box, connection via industrial plug connection, stable and durable AC wall box made of powder-coated steel (in desired RAL colour), for wall mounting outdoors or indoors, charging connection plug type 2, with integrated DC residual current detection and protection against overload or electric shocks</p>	1 unit	99515004	08
	<p>For technical data, see wall box epoint WB 2.0, item no. 99515003</p>			

Item	Item description	PU	Item No.	PG
	<p>Charging point epoint LP 5.0 (only in conjunction with epoint charging station LS 5.0) Charging point with 22 kW charging power</p> <p>Legally calibration-compliant billing of charging power to users via eparkstation software system, used via app</p> <p>COMMUNICATION: LED indicator, communication via Wi-Fi and ACCP 1.6, Ethernet interface INPUT: Power supply: 3P+N+PE AC, rated power: 400 V AC, rated current: 64 A, residual current circuit breaker type A, FI/LS C32A, <30mA, protection class IP44, frequency: 50 Hz, operating temperature: -30 °C to +50 °C OUTPUT: Output voltage 400 V AC, maximum current 2 x 32 A, rated power 2 x 22 kW, CE marking, 2 years warranty, floor stand assembly Product dimensions: (HxWxD) 400 x 300 x 155 mm Net weight: 15.0 kg, packaged in carton</p>	1 unit	99515005	08
	<p>Charging station epoint LS 5.0 for up to 2 charging points with a charging capacity of 22 kW, made of powder-coated steel (design according to customer specifications), for free-standing installation outdoors or indoors, Type 2 charging connector, with integrated DC residual current detection and lightning strike protection</p> <p>Legally calibration-compliant billing of charging power to users via eparkstation software system, used via app</p> <p>COMMUNICATION: LED indicator, communication via Wi-Fi and OCCP 1.6, Ethernet interface INPUT: Power supply: 3P+N+PE AC, rated power: 400 V AC, rated current 64 A, residual current circuit breaker type A, FI/LS C32A, <30 mA protection class IP44, frequency: 50 Hz, Operating temperature: -30 °C to +50 °C OUTPUT: Output voltage 400 V AC, maximum current 2 x 32 A, Rated power 2 x 22 kW, shock resistance IK10, CE marking, 2-year warranty, floor stand mounting Product dimensions: (HxWxD) 1420 x 750 x 370 mm Net weight: 100.0 kg FOR USE IN: Public spaces</p>	1 unit	99515002	08
	<p>Flat rate for subsidy application consultation Selection and coordination of appropriate subsidies, Support in the application process</p>	1 unit	99515200	08

NOTE

Before starting the planning, the local network operator must be contacted to find out about any special provisions that apply to the installation of charging stations. According to the VDE 0100-722 standard, the charging station must be supplied via a separate circuit. Each charging point must be secured with a circuit breaker. The rated differential current must not exceed 30 mA. The protective device must be at least type A. If DC fault currents >6 mA cannot be excluded, a type B FI must be used. The maximum charging current of the charging station determines the dimensioning of the protective device as well as the cable cross-section. The use of overcurrent protection devices with C-characteristics is recommended.

Completing the electrical connections of our eparkstation charging solutions requires technical expertise/ specialised knowledge!

Please note that, depending on the version or configuration, costs for operation, use, provision, insurance, customisation (hardware/software), upgrades and SIM cards will apply. The order processing for this is carried out by our partner company iSATT GmbH, 53115 Bonn, info@isatt.de.



The eparkstation software system

THE BRAIN OF CHARGING INFRASTRUCTURE

The **eparkstation software system** enables simple, user-friendly use of the entire epoint charging system. The surface can be freely adapted based on your ideas for the visual appearance or your company's corporate design. Even existing charging points from third-party manufacturers can be easily integrated into the software.

The **eparkstation software system** controls the entire EV charging infrastructure like an operating system. It is an easy-to-use tool and can integrate existing third-party systems on request. The system is flexible, offers extensive possibilities and turns your parking space into a smart EV charging station in no time. This allows you to conveniently control the epoint charging station in your user portal, where you can also perform fleet management or manage billing.

The charging itself is conveniently handled via smartphone with the **eparkstation app or PayPal**: the user pays as a guest via PayPal by scanning the QR code or as a registered user via direct debit from their account, receives an overview of all charging systems (wall box or station), reservation options, data evaluation and much more.

The eparkstation software system impresses:

- Easy, user-friendly use of the entire **epoint** charging system
- Freely configurable according to customer specifications
- Easily register to use the eparkstation app for long-term comfort and maximum transparency
- Option for one-time use (without registration) by scanning a QR code and simple billing (via PayPal)
- Operator portal with location management, overview/frequencies of use, real-time data during the charging process, fleet management, location of nearby **epoint** charging systems and availability, and much more
- Individualised, visual design of your operator portal based on your company's corporate design
- Current overview of the applicable rates for charging current, charging time and parking duration

Item	Item description	PU	Item No.	PG
	eparkstation software system for easy and user-friendly control of all epoint charging systems, design of the user interface according to customer specifications within the available layouts (incl. a correction loop)	1 unit	99515101	08

NOTE

The eparkstation software system takes into account different applications. The customer can choose whether to take over the management of the charging infrastructure in its entirety, in part, or not at all. We will be happy to advise you on finding the ideal solution for your project.

Insulate properly with EMPUR®

15.1 Minimum thermal insulation according to GEG and surface heating standard DIN EN 1264

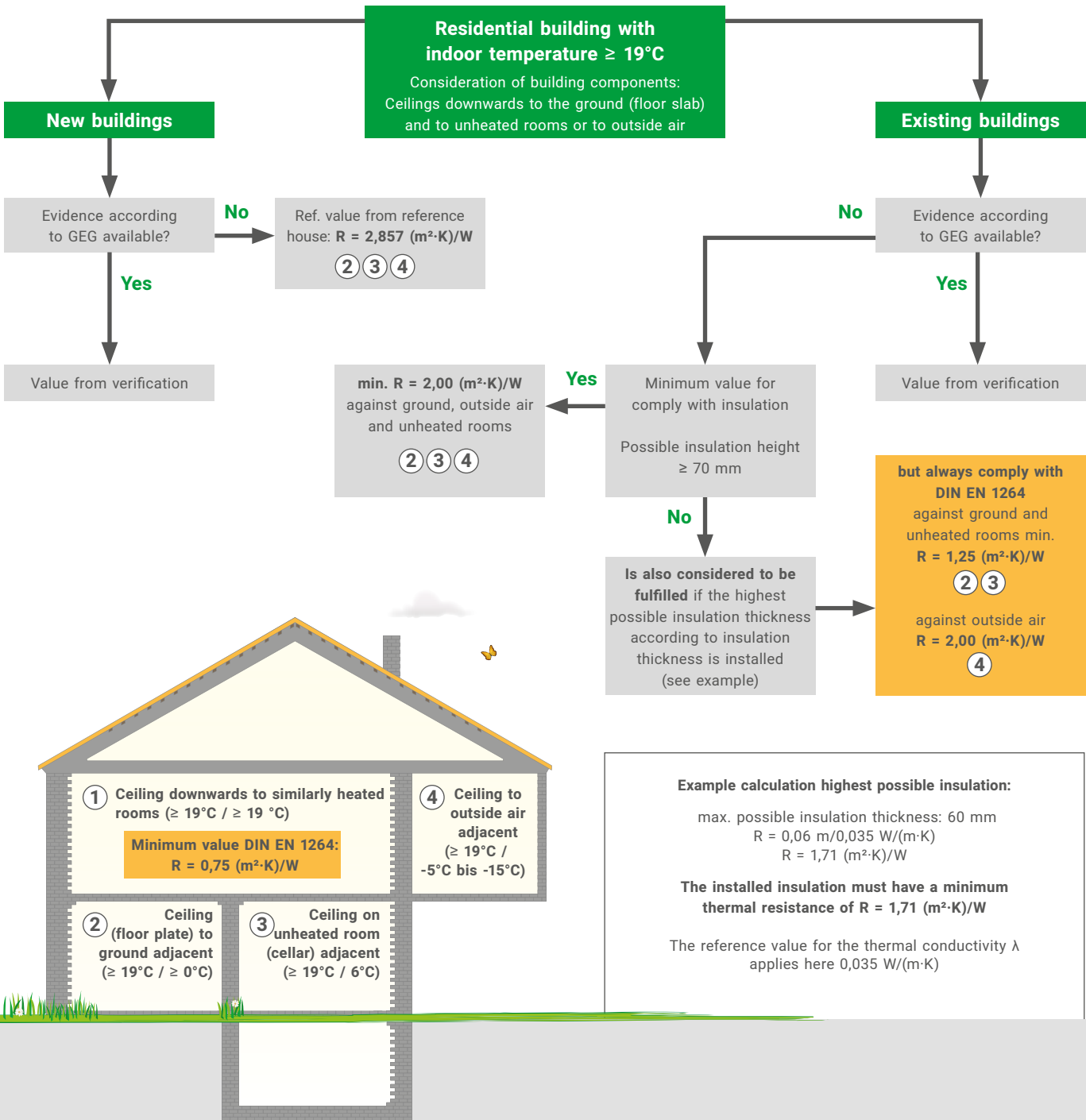

The "Act on Energy Saving and the Use of Renewable Energies for Heating and Cooling in Buildings (Building Energy Act – GEG)" came into force on November 1, 2020. It combines the EnEG (Energy Saving Act), the EEWärmeG (Renewable Energies Heat Act) and the EnEV (Energy Saving Ordinance) into one law. The purpose of the act (§ 1) is the most economical use of energy in buildings possible, including an increasing use of renewable energies ..., taking into account economic efficiency (§ 5) ..., if the requirements can be met according to the state of the art (§ 7)! The client or owner is responsible for compliance with the regulations (§ 8), ... and/or also persons acting on his behalf in the construction or alteration of buildings or the systems engineering in buildings.

NOTE If a subsidy is applied for, e.g. "Federal subsidy for efficient buildings (BEG)", other values or specifications must be taken into account!

15.1 Minimum thermal insulation according to GEG and surface heating standard DIN EN 1264

①

Insulation for flat partition ceiling above rooms with similar use ($\geq 19^\circ\text{C}/\geq 19^\circ\text{C}$)

Examples of underfloor heating with PUR-THERM® composite panels and heating pipe 15 x 1,8

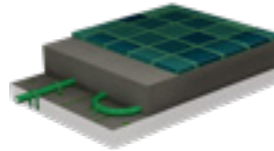

60 mm heating screed incl.
system pipe 15 x 1.8 mm

35 mm composite panel Turbo Cube® WLS 045

95 mm (without lining) $R = 0.778 \text{ (m}^2\cdot\text{K)/W}$

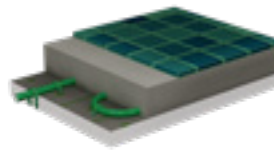

60 mm heating screed incl.
system pipe 15 x 1.8 mm

30 mm composite panel "V5" WLS 040

90 mm (without lining) $R = 0.750 \text{ (m}^2\cdot\text{K)/W}$

② ③ ④

Insulation against ground, outside air or unheated/partially heated rooms (cellar)

Examples of underfloor heating with PUR-THERM® composite panels and heating pipe 15 x 1,8

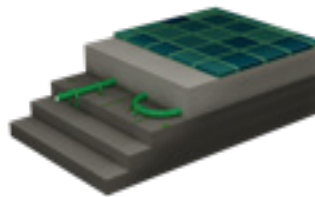

60 mm heating screed incl.
system pipe 15 x 1.8 mm

30 mm composite panel "Kompakt" WLS 032

30 mm additional insulation EPS-DEO WLS 032

30 mm additional insulation EPS-DEO WLS 032

150 mm (without lining) $R = 2.813 \text{ (m}^2\cdot\text{K)/W}$

NOTE

Heat and sound insulation certificates must always be observed!

Insulate properly with EMPUR®

15.2 The PUR philosophy

With EMPUR® polyurethane products, all thermal insulation requirements can be reliably realised and complied with in the long term. The PUR insulation material has outstanding properties such as

- optimal insulation
- durability
- stability in form and dimension
- Compressive strength (\wedge 100 kPa)
- water repellent
- mould and rot resistance
- chemical resistance
- standards in accordance with EN 13165

Optimum installation in the PUR-THERM® house



Top floor:

- Composite panel PUR/PE 23 "Exclusiv" (Item no. 042300)



Ground floor:

- Composite panel PUR/PE 14 "Exclusiv" (Item no. 041400)
- 2. Additional insulation EPS DEO dm WLS 035
- 1. Additional insulation EPS DEO dm WLS 035

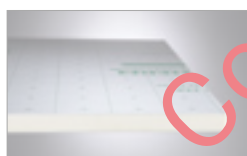

Basement, left:

- Composite panel PUR/PE 33 "Exclusiv" (Item no. 043300)
- 2. Additional insulation EPS DEO dm WLS 032
- 1. Additional insulation EPS DEO dm WLS 032



Basement, right:

- Composite panel "Kompakt" EPS DEO dm 30 (Item no. 023060)
- 2. Additional insulation EPS DEO dm WLS 032
- 1. Additional insulation EPS DEO dm WLS 032



NOTE

Heat and sound insulation certificates must always be observed!

Polyurethane is a closed-cell rigid foam and can be found in countless areas of industrial application. The material has proven itself millions of times over.

By manufacturing different panel thicknesses and designs – with highly tear-resistant multi-layer composite foil for use with our staple system, with velcro foil for our exclusive velcro system or as additional insulation with an aluminium/aluminium layer – you can use our systems to achieve the most diverse construction heights and implement the most demanding projects.

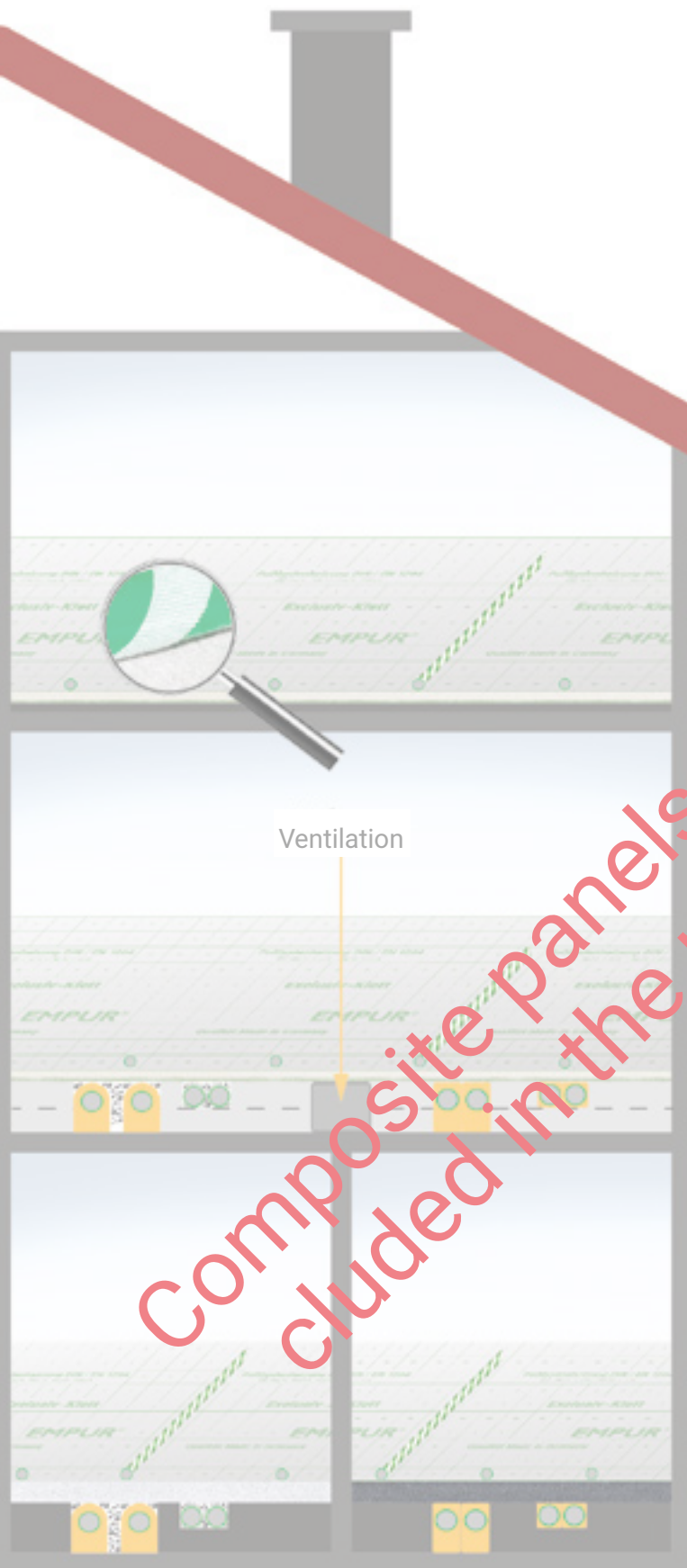

 hard bed

Optimum installation in the Exclusiv-Klett house

Top floor:

- Composite panel PUR/PE 15 "Exclusiv-Klett" (Item no. 070414)
- 1. Additional insulation EPS DEO dm WLS 032

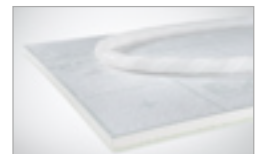

Ground floor:

- Composite panel PUR/PE 15 "Exclusiv-Klett" (Item no. 070414)
- 2. Additional insulation EPS DEO dm WLS 035
- 1. Additional insulation EPS DEO dm WLS 035



Basement, left:

- Composite panel PUR 23 "Exclusiv-Klett" (Item no. 070424)
- 2. Additional insulation EPS DEO dm WLS 032
- 1. Additional insulation EPS DEO dm WLS 032

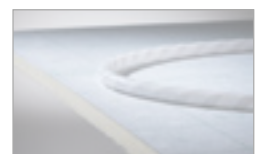

Basement, right:

- Composite panel "Klett-Kompakt" EPS DEO dm 30 (Item no. 070236)
- 2. Additional insulation EPS DEO dm WLS 032
- 1. Additional insulation EPS DEO dm WLS 032



Insulate properly with EMPUR®

15.3 Thermal resistance of the insulation materials (R-value table)

R-values for PUR-THERM® Exclusiv composite panels in combination with PUR/ALU/ALU or EPS DEO WLS 032

Insulating panel (PUR CP/TC/TN)	0.625	0.938	1.250	1.563	1.875	R-value
	EPS-DEO WLS 032					
	20 mm	30 mm	40 mm	50 mm	60 mm	
			(20+20)	(20+30)	(30+30)	
CP-/TC- 25-2	1.181	1.494	1.806	2.119	2.431	R-value
R-value [m² K/W]	45	55	65	75	85	height insulat.
0.556	105	115	125	135	145	(*) Total height
CP-/TC- 30-3	1.292	1.605	1.917	2.230	2.542	R-value
R-value [m² K/W]	50	60	70	80	90	height insulat.
0.667	110	120	130	140	150	(*) Total height
CP-/TC- 35-3	1.403	1.716	2.028	2.341	2.653	R-value
R-value [m² K/W]	55	65	75	85	95	height insulat.
0.778	115	125	135	145	155	(*) Total height
TN11 EPS-DEO	0.939	1.252	1.564	1.877	2.189	R-value
R-value [m² K/W]	31	41	51	61	71	height insulat.
0.314	91	101	111	121	131	(*) Total height
TN30-2 EPS-DES	1.375	1.688	2.000	2.313	2.625	R-value
R-value [m²K/W]	50	60	70	80	90	height insulat.
0.750	110	120	130	140	150	(*) Total height

CP = composite panel

TC = Turbo Cube

TN = top-Nopp

16.1 Pressure loss diagram for KLIMAPEX® plastic heating pipes

Chart for pressure loss determination for different pipe diameters, depending on the volume flow

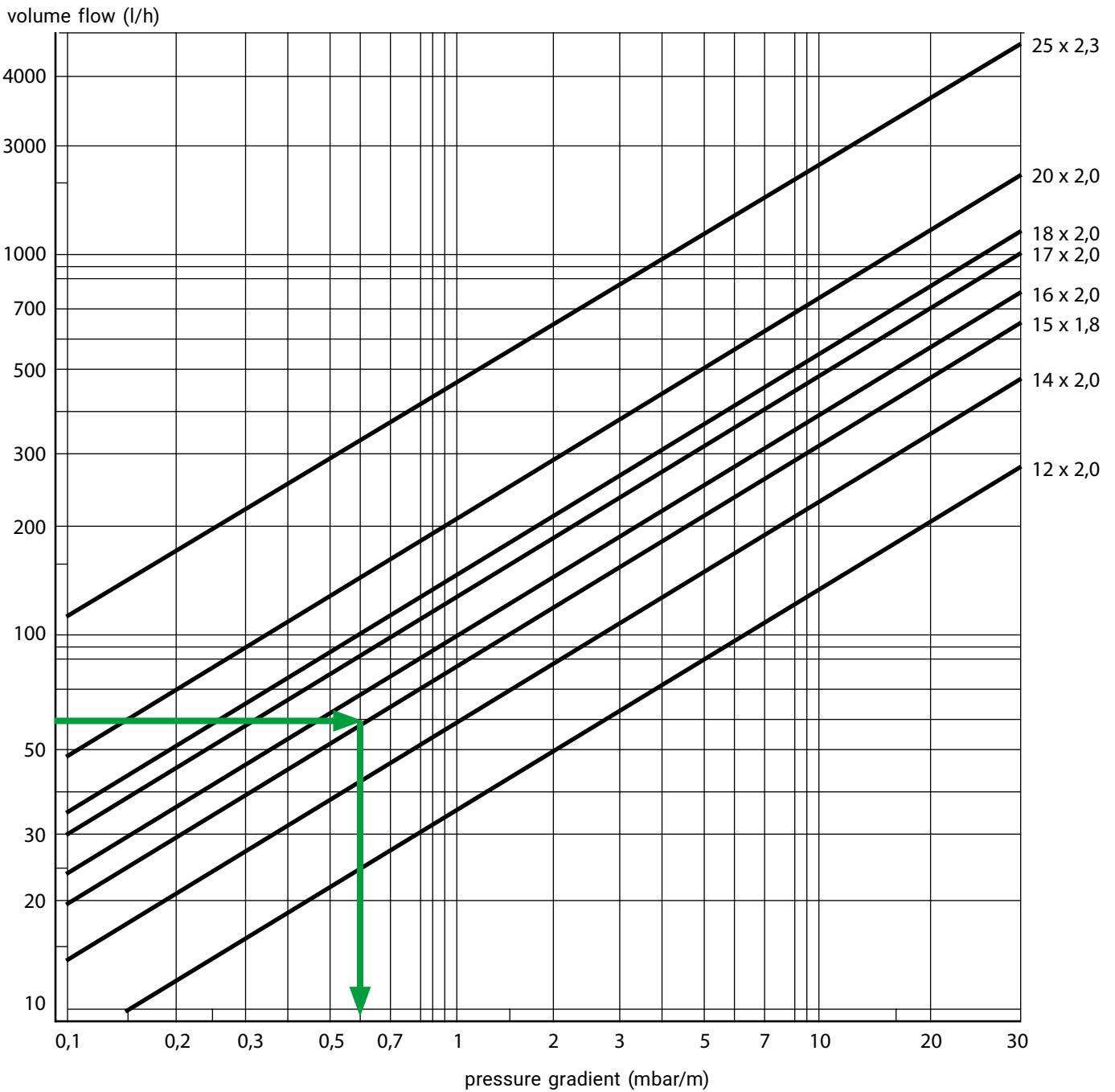

Example: Volume flow approx. 60 l/h, 0.6 mbar/m

A volume flow, read on the volume rate indicators, of just one litre per minute (60 litres per hour) results in a pressure loss of approx. 0.6 mbar per metre of pipe length with a 15 mm plastic pipe

CUT-THERM® Modernisierung

Angebotservice Überschlagskalkulation

Anschrift Installateur: _____ **Anschrift Großhändler:** _____

Ansprechpartner: _____ **ADM:** _____

Tel./Fax: _____ Tel./Fax: _____

E-Mail: _____ E-Mail: _____

Bauvorhaben: _____

Projektnummer: _____ Außentemperatur: _____ °C

Name: _____ Spezifische Heizlast: _____ °C

Straße: _____

PLZ, Ort: _____ Tel.-Nr. für Rückfragen: _____

Grundrisse (maßstäblich)
Liegen keine Pläne vor, so sind diese vor Angebotsanforderung zu erstellen, bzw. der Grundriss mit Flächenangaben auf einem separaten Blatt mitzulegen. Die Einbaureihe der Heizkreisläufe

Estrichstärke _____ (mm)
Die Mindeststärke muss 40 mm betragen. Die Estrichstärke muss pro 10 m² mindestens an eine Es können ausschließlich Zement-, Gussasphalt- und Anhydritestriche gefasst werden. Die Ober der Arbeiten vollständig, inklusive evtl. Kleber, entfernt werden.

Verteilerbauart: HKV-D mit Durchflussmengenanzeiger, Klemmverschraubungen und Rohr Regelverteiler HKV-R mit „Regelset K“, Thermoweiche, Anschluss-Set, Str Klemmverschraubungen und Rohr PE-RT 15 x 1,8

Flächen (m²)

	Bodenbeläge	Teppich	Fliesen
KG: _____ m ²	Wohnräume: <input type="checkbox"/>	<input type="checkbox"/>	<input type="checkbox"/>
EG: _____ m ²	Küche/Diele: <input type="checkbox"/>	<input type="checkbox"/>	<input type="checkbox"/>
OG: _____ m ²	Nassräume: <input type="checkbox"/>	<input type="checkbox"/>	<input type="checkbox"/>
DG: _____ m ²	Sonstige: <input type="checkbox"/>	<input type="checkbox"/>	<input type="checkbox"/>

Verteilerschrank: Top Standard (AP) Exklusiv (UP) Exklusiv plus (UP)

Regelungstechnik: Heizen Heizen/Kühlen Funk Exklusiv Funk

Anlagen: Schnitte Grundrisse Ansichten andere

An wen soll das Angebot geschickt werden? Großhandel Installateur andere

Bemerkungen: _____

Angebot wird gewünscht bis: _____ **Datum:** _____

Für die Erstellung einer Überschlagskalkulation sind 4 Werktage einzurechnen. Bitte füllen Sie zur Erstellung eines unverbindlichen Angebotes das Serviceblatt komplett und leserblich aus.

Bestandsaufnahme CUT-THERM®

Ortstermin am: _____ **Angebot:** _____

Anschrift Installateur/HZB: _____ **Anschrift Großhändler:** _____

Ansprechpartner: _____ **ADM:** _____

Tel./Fax: _____ Tel./Fax: _____

E-Mail: _____ E-Mail: _____

Bauvorhaben: _____ **Geplante Ausführ.**

Name: _____

Straße: _____ PLZ/Ort: _____

Telefon: _____ E-Mail: _____

Zugang zum Gebäude ja nein

Begehung der Etagen über Treppe möglich ja nein

Estrichstärke _____ (mm) Bohrungen werden vom Installateur/ Wo? _____

Randdämmstreifen vorhanden ja nein

Verteilerbauart: HKV-D mit Durchflussmengenanzeiger, Klemmverschraubungen Regelverteiler HKV-R mit „Regelset K“, Thermoweiche, Anschluss-Set, Str Klemmverschraubungen und Rohr PE-RT 15 x 1,8

Standorte _____

Verteiler vorab an HZB ja nein

Sanierung folgender Räume:

	KG	EG	OG	DG	Fläche	geplanter Betrag	Einbaureihe	PE-RT	Rohr-Wert
Wohnen									
Essen									
Küche									
Flur									
Schlafen									
Kind 1									
Kind 2									
Büro									
Bad									
Gäste WC									

Anfangsmöglichkeit ja nein

Parkmöglichkeit ja nein

Grundrisse erhalten ja nein

Heizlastberechnung vorhanden ja nein

Allgemeine Hinweise gegeben ja nein

Hinweis Betagsaufbau ja nein

Eintragung Freigabe bauseits, Container vorh. ja nein

Stromanschluß (380 Volt, 32 A/2 x 16 A) ja nein

Datum _____ **Unterschrift Bauherr** _____

EMPUR® Fußbodenheizung

Angebotservice Überschlagskalkulation

EMPUR®

HINWEIS: Gemäß VOB ist für die Auslegung eine Heizlastberechnung nach DIN EN 12831 erforderlich! Die Heizlastberechnung bieten wir Ihnen gegen Kostenberechnung von 125 €/m². Eine Rückvergütung in Höhe von 60€/m² erfolgt, wenn alle angebotenen EMPUR® Komponenten im Bereich der Flächenheizung zum Einsatz kommen. Zum Nachweis sind die objektbezogenen Lieferrechnungen einzureichen. Verwenden Sie dazu unser Formular Heizlastberechnung auf www.empur.com/de/service/downloads/

Anschrift Installateur: _____ **Anschrift Großhändler:** _____

Ansprechpartner: _____ **ADM:** _____

Tel./Fax: _____ Tel./Fax: _____

E-Mail: _____ E-Mail: _____

Bauvorhaben/Projektnummer: _____

Name: _____ Außentemperatur: _____ °C Systemtemperatur: _____ °C

Straße: _____ Wärmereizueger: _____

PLZ, Ort: _____ Tel.-Nr. für Rückfragen: _____

System: PUR-THERM® (Tacksystem) Exklusiv-Kleitt Faserplatte „Kleitt“ OPTIMAL II Trockenbau top-Nopp® top-Nopp® mini Deckenheizung/-kühlung Wohnungsübergabestation Wandheizung OPTIMAL II Trockenbausystem Wandelemente Gipskarton Naassystem Wand vertikal

Rohrtyp: PE-Xa PE-RT 4 bar PE-RT 6 bar PE-RT (AL/PE-RT) PE-RT (AL/PE-RT) Rohr-Ø _____ mm / VA _____ mm

Verteilerbauart: **Edelstahl:** HKV-D HKV-DB (Balance) Thermoweiche Messing: HKV-D HKV-G Messing HKV-G Edelstahl Thermoweiche Anschluss-Set 90° DG

Regelstationen: HKV-D Regelset „K“ Regelset „V“ Contemp alpha

Verteilerschrank: Top Standard (AP) Exklusiv (UP) Exklusiv plus (UP)

Top Standard-plus Economy (AP) Economy (UP)

Regelungstechnik: Heizen Heizen/Kühlen Balance H/K Funk Exklusiv Funk BUS

Anlagen: Schnitte Grundrisse Ansichten Wärmeschutznachweis kein Wärmeschutznachweis vorhanden Wärmeschutz gemäß GEG Anlage 1, Referenzgebäude Spezifische Heizlast: _____ W/m²

Aufbauhöhen: KG: _____ mm **Dämmung bzw. Dämmkombination:** _____

EG: _____ mm _____

OG: _____ mm _____

DG: _____ mm _____

Bodenbeläge Wohnräume: Teppich Fliesen andere

Bodenbeläge Küche/Diele: Teppich Fliesen andere

Bodenbeläge Nassräume: Fliesen andere

Die Einbaureihe der Heizkreisläufe sind im Plan anzugeben. Keller beheizt: ja nein

An wen soll das Angebot geschickt werden? Großhandel Installateur andere

Bemerkungen: _____

Angebot wird gewünscht bis: _____ **Datum:** _____

Für die Erstellung einer Überschlagskalkulation sind 4 Werktage einzurechnen. Bitte füllen Sie zur Erstellung eines unverbindlichen Angebotes das Serviceblatt komplett und leserblich aus.

(Stempel/Unterschrift)

Formular senden

EMPUR® Protokoll Funktionsheizen

CUT-THERM® Modernisierung

gemäß DIN EN 1264 Teil 4

Auftraggeber: _____

Bauvorhaben: _____

Baubeschritt: _____

Stockwerk/Wohnung: _____

System: CUT-THERM® Fußbodenheizung
CUT-THERM® PE-RT 15 x 1,8 mm
Heizrohr: KLIMAPEX® PE-RT 15 x 1,8 mm

Art des Estrichs: Zementestrich Anhydritestrich

Die DIN EN 1264 schreibt vor:
Das Funktionsheizen darf bei keramischen Oberbelägen frühestens 10 Tage nach der Verlegung von Oberbelägen, z.B. Parkett, sind die Herstellerangaben des Klebstoffherstellers zu schwimmend verlegt, so kann die Aufheizung unmittelbar nach Fertigstellung der Arbeiten erfolgt. Das Funktionsheizen beginnt mit einer Vorlauftemperatur zwischen 20°C und 25°C, die mit ist. Anschließend muss die maximale Auslegungstemperatur eingestellt und mindestens 41 10 Minuten. Der Vorgang des Funktionsheizens muss dokumentiert werden.

Beginn des Funktionsheizens: _____ (Vorlauftemperatur zw. 20/25 °C, Dauer 3 Tage) **Datum/Uhrzeit:** _____ **Vorlauftemperatur:** _____

Funktionsheizen nach 3 Tagen: _____ (max. Vorlauftemperatur, Dauer 4 Tage) **Datum/Uhrzeit:** _____ **Vorlauftemperatur:** _____

Ende des Funktionsheizens: _____ (Datum/Uhrzeit)

Die Aufheizung wurde unterbrochen: nein ja von _____ (Datum)

Bemerkungen: _____

Das ordnungsgemäß durchgeführte Funktionsheizen wird hiermit bestätigt. Am gesamten Fußbodenaufbau wurden keine Mängel festgestellt.

(Datum/Unterschrift/Stempel) Bauherr/Auftraggeber

(Datum/Unterschrift/Stempel) Fachunternehmer

Für die Berechnung der Norm-Heizlast nach DIN EN 12831 und die Auslegung der Flächenheizung sind 8 Werktage einzurechnen. Bitte beachten Sie auch die Checkliste zur Berechnung der Heizlast PB 78-08.

Auftrag zur Berechnung der Heizlast

nach DIN EN 12831

Für die nach Norm zu berechnenden Flächen werden 125 €/m² in Rechnung gestellt. Die Rechnung eine Rückvergütung in Höhe von 60€/m² erfolgt, wenn alle angebotenen EMPUR® Komponenten im Bereich der Flächenheizung zum Einsatz kommen. Zum Nachweis sind die objektbezogenen Lieferrechnungen einzureichen. Um ein den normativen Vorgaben entsprechende Heizlastberechnung erstellen zu können, bitten nummer vollständig auszufüllen.

Anschrift Installateur: _____ **Anschrift Großhändler:** _____

Ansprechpartner: _____ **ADM:** _____

Tel./Fax: _____ Tel./Fax: _____

E-Mail: _____ E-Mail: _____

Bauvorhaben: _____ **Auftrags-/Best.**

Projektnummer: _____

Name: _____ Außentemperatur: _____

Straße: _____ Wärmereizueger: _____

PLZ, Ort: _____ Tel.-Nr. für Rückf: _____

System: PUR-THERM® (Tacksystem) Exklusiv-Kleitt Faserplatte „Kleitt“ top-Nopp® top-Nopp® mini Deckenheizung Wandheizung OPTIMAL II Trockenbausystem Wandelemente Gipskarton Naassystem Wand vertikal

Rohrtyp: PE-Xa PE-RT 4 bar PE-RT 6 bar PE-RT (AL/PE-RT) PE-RT (AL/PE-RT) Rohr-Ø _____ mm / VA _____ mm

Verteilerbauart: **Edelstahl:** HKV-D HKV-DB (Balance) Thermoweiche

Komplettverteiler Geniax: HKV-G Messing HKV-G Edelstahl Thermoweiche

Regelstationen: HKV-D Regelset „K“ Regelset „V“ Contemp alpha

Verteilerschrank: Top Standard (AP) Exklusiv (UP) Exklusiv plus (UP)

Top Standard-plus Economy (AP) Economy (UP)

Regelungstechnik: Heizen Heizen/Kühlen Balance H/K Funk Exklusiv Funk BUS

Anlagen: Schnitte Grundrisse Ansichten Wärmeschutznachweis kein Wärmeschutznachweis vorhanden Wärmeschutz gemäß GEG Anlage 1, Referenzgebäude Spezifische Heizlast: _____ W/m²

Aufbauhöhen: KG: _____ mm **Dämmung bzw. Dämmkombination:** _____

EG: _____ mm _____

OG: _____ mm _____

DG: _____ mm _____

Bodenbeläge Wohnräume: Teppich Fliesen andere

Bodenbeläge Küche/Diele: Teppich Fliesen andere

Bodenbeläge Nassräume: Fliesen andere

Die Einbaureihe der Heizkreisläufe sind im Plan anzugeben. Keller beheizt: ja nein

An wen soll das Angebot geschickt werden? Großhandel Installateur andere

Bemerkungen: _____

Angebot wird gewünscht bis: _____ **Datum:** _____

Für die Berechnung der Norm-Heizlast nach DIN EN 12831 und die Auslegung der Flächenheizung sind 8 Werktage einzurechnen. Bitte beachten Sie auch die Checkliste zur Berechnung der Heizlast PB 78-08.

EMPUR® Protokoll Dichtheitsprüfung

CUT-THERM® Modernisierung

EMPUR®

Auftraggeber: _____

Bauvorhaben: _____

Baubeschritt: _____

Stockwerk/Wohnung: _____

System: CUT-THERM® Fußbodenheizung **Heizrohr:** KLIMAPEX® PE-RT 15 x 1,8 mm

Anforderungen gemäß DIN EN 1264-4 / BVP:

Die Dichtheit der Heiz-/Kühlweise der Flächenheizung/Fächenkühlung wird unmittelbar vor der Estrich-, Putz- bzw. Ausgussmassenverlegung durch eine Wasserdruckprobe sichergestellt. Der Prüfdruck beträgt hier abweichend von der VOB C (DIN 18380) mindestens 1,3 mal maximaler Betriebsdruck der Anlage und nicht mehr als 6 bar. Dieser Druck muss während des Einbaus des Estrichs/Putzes aufrechterhalten bleiben. Die Dichtheitsprüfung erfolgt schrittweise nach dem Spülen der einzelnen Heizkreisläufe. Es ist sicherzustellen, dass weitere Anlageeile vor zu hohem Druck geschützt werden (ggf. durch Hauptabsperrungen vor dem Verteiler). Bei Frostgefahr müssen geeignete Maßnahmen getroffen werden, wie z.B. die Verwendung von Frostschutzmitteln oder die Temperierung des Gebäudes. Zu Beginn des Normalbetriebes des Systems können alle Frostschutzmittel entsprechend den nationalen Arbeitsschutzbestimmungen abgelassen und entsorgt werden; das System muss anschließend dreimal mit sauberem Wasser gespült werden.

Alternativ kann die Dichtheitsprüfung auch mit Druckluft durchgeführt werden. Der Prüfdruck beträgt hier abweichend maximal 3 bar (+/- 0,2 bar). **Nach erfolgter Dichtheitsprüfung ist der Druck abzubauen, um Schäden an den Heizrohren zu verhindern!**

HINWEIS: Die Richtwerte für die Wasserbeschaffenheit in der Anlage sind gemäß VDI 2035 zu beachten und einzuhalten. Die Voreinstellung der Heizkreise ist erst nach der Dichtheitsprüfung/dem Spülen der Anlage vorzunehmen.

Dokumentation:

	Wasserdruckprobe	Luftdruckprobe
Maximal zulässiger Betriebsdruck	6 bar	3 bar
Prüfdruck	_____ bar	_____ bar
Belastungsdauer (Empfehlung: 1 h)	_____ h	_____ h

Beginn der Dichtheitsprüfung (Datum/Uhrzeit) _____ bei Außentemperatur _____ °C

Ende der Dichtheitsprüfung (Datum/Uhrzeit) _____ bei Außentemperatur _____ °C

Bemerkungen: _____

Die Dichtheit wird hiermit bestätigt, bleibende Formänderungen sind nicht aufgetreten.

(Datum/Unterschrift/Stempel) Bauherr/Auftraggeber

(Datum/Unterschrift/Stempel) Fachunternehmer

(Datum/Unterschrift/Stempel) Bauleitung/Architekt

Für die Berechnung der Norm-Heizlast nach DIN EN 12831 und die Auslegung der Flächenheizung sind 8 Werktage einzurechnen. Bitte beachten Sie auch die Checkliste zur Berechnung der Heizlast PB 78-08.

Formular senden

NOTE

All forms are available on our website and can be filled out online (www.empur.com/de/service/downloads/). To fill in these forms, you need to download them.



Warranty Certificate

We only manufacture and supply quality products.
We furnish a warranty for the system components supplied by us for 10 years from date of delivery.

Heating Pipes

Free replacement if damage occurs to the heating pipes and PU plates which can be demonstrably attributed to manufacturing defects and for which we are at fault. For your further protection against damage to the heating pipes that we supply, we have a product liability insurance with a sum insured of

EUR 2.5 Million/Insured Claim
EUR 5 Million/Year

Within the above mentioned period, we also assume liability for damages caused to third party property because of a fault to the heating pipes that we supply and for which we are responsible. Insofar as claims go beyond our liability according to legal provisions, we are only liable insofar as the claim assigned to us is covered by insurance protection from our product liability insurance.

The prerequisite for our liability is always:

- The exclusive use of our approved system components.
- Compliance with our planning, operating and installation instructions.
- Compliance with the relevant technical standards.
- Professional installation by an authorised specialist company.

We are free to fulfil our obligation in the form of a replacement delivery or repair carried out by us or by third parties.
In addition, our General Terms and Conditions as amended shall apply.

We hereby assume the warranty for any consequential damages to our EMPUR® surface heating in accordance with this warranty certificate for the following object:

Construction project: _____

Street, P.O. Box/Place: _____

Executing specialist company: _____

Date of installation/commissioning: _____

Buchholz-Mendt, _____

Signature: _____

FB-TK-012_Gewehreistungsurkunde_engl_6_201021



EMPUR® Produktions GmbH • Industriepark Nord 60 • 53567 Buchholz-Mendt • Germany
phone +49 2683 96062-0 • fax +49 2683 96062-99 • info@empur.com • www.empur.com

DIN CERTCO
Institution für Zertifizierung

ZERTIFIKAT

Zertifizierter: EMPUR Produktionsgesellschaft mbH
Industriepark Nord 60
53567 Buchholz-
Mendt
DEUTSCHLAND

Produkt: Kunststoffrohr- und Verbundrohrleitungssysteme für
Wasser- und Heizkörperanbindungen

Typ, Modell: PE-RT

Prüfgrundlage(n): DIN 4726:2017-10
DIN EN ISO 22391-2:2010-04
DIN EN ISO 22391-3:2010-04
DIN EN ISO 22391-5:2010-04
Zertifizierungsprogramm Kunststoffrohr- und Verbund-
Wassers-Flächenheizungen und Heizkörperanbindungen

Konformitätszeichen: 

Registernummer: 3V204 PE-RT

Gültig bis: 2028-04-30

Nutzungsrecht: Dieses Zertifikat berechtigt zum Führen des oben stehenden Konformitätszeichens in Verbindung mit der genannten Registernummer.
Weitere Angaben siehe Anhang.

2023-05-11
Dipl.-Ing. Katharina Vehrung, M. Eng.
Zertifizierungsstelle



DAKS
Deutsches Institut für
Zertifizierung

DIN CERTCO Institution für Zertifizierung mbH | Albrechtstraße 16 | D-52229 Berlin | www.din-certco.de

DIN CERTCO
Institution für Zertifizierung

ZERTIFIKAT

Zertifizierter: EMPUR Produktionsgesellschaft mbH
Industriepark Nord 60
53567 Buchholz
DEUTSCHLAND

Produkt: Raumflächenintegrierte Heiz- und Kühlsysteme
Fußböden, Decken und Wänden

Typ, Modell: Guchiv-Klatt PE-RT 25

Prüfgrundlage(n): DIN EN 1294-2:2013-08
DIN EN 1294-3:2009-11
DIN EN 1294-4:2009-11
Zertifizierungsprogramm Raumflächenintegrierte
Wassers-Flächenheizungen (2023-10)

Konformitätszeichen: 

Registernummer: 3V204-F

Gültig bis: 2027-07-31

Nutzungsrecht: Dieses Zertifikat berechtigt zum Führen des oben stehenden Konformitätszeichens in Verbindung mit der genannten Registernummer.
Weitere Angaben siehe Anhang.

2023-07-28
Dipl.-Ing. Lars Senf
Leiter der Zertifizierungsstelle



DAKS
Deutsches Institut für
Zertifizierung

DIN CERTCO Institution für Zertifizierung mbH | Albrechtstraße 16 | D-52229 Berlin | www.din-certco.de

DIN CERTCO
Institution für Zertifizierung

ZERTIFIKAT

Zertifizierter: EMPUR Produktionsgesellschaft mbH
Industriepark Nord 60
53567 Buchholz
DEUTSCHLAND

Produkt: Raumflächenintegrierte Heiz- und Kühlsysteme mit Wasserschleife in
Fußböden, Decken und Wänden

Typ, Modell: 781 Optimal 32

Prüfgrundlage(n): DIN EN 1294-2:2013-08
DIN EN 1294-3:2009-11
DIN EN 1294-4:2009-11
Zertifizierungsprogramm Raumflächenintegrierte Heiz- und Kühlsysteme mit
Wasserschleife in (2023-10)

Konformitätszeichen: 

Registernummer: 3V205-F

Gültig bis: 2027-07-31

Nutzungsrecht: Dieses Zertifikat berechtigt zum Führen des oben stehenden Konformitätszeichens in Verbindung mit der genannten Registernummer.
Weitere Angaben siehe Anhang.

2023-08-27
Dipl.-Ing. Katharina Vehrung, M. Eng.
Zertifizierungsstelle



DAKS
Deutsches Institut für
Zertifizierung

DIN CERTCO Institution für Zertifizierung mbH | Albrechtstraße 16 | D-52229 Berlin | www.din-certco.de

DIN CERTCO
Institution für Zertifizierung

ZERTIFIKAT

Zertifizierter: EMPUR Produktionsgesellschaft mbH
Industriepark Nord 60
53567 Buchholz
DEUTSCHLAND

Produkt: Raumflächenintegrierte Heiz- und Kühlsysteme mit
Fußböden, Decken und Wänden

Typ, Modell: WL - Industrie

Prüfgrundlage(n): DIN EN 1294-2:2013-08
DIN EN 1294-3:2009-11
DIN EN 1294-4:2009-11
Zertifizierungsprogramm Raumflächenintegrierte Heiz- und
Kühlsysteme mit Wasserschleife in (2009-11)

Konformitätszeichen: 

Registernummer: 3V214-F

Gültig bis: 2024-03-28

Nutzungsrecht: Dieses Zertifikat berechtigt zum Führen des oben stehenden Konformitätszeichens in Verbindung mit der genannten Registernummer.
Weitere Angaben siehe Anhang.

2023-03-28
Dipl.-Ing. Katharina Vehrung, M. Eng.
Zertifizierungsstelle



DAKS
Deutsches Institut für
Zertifizierung

DIN CERTCO Institution für Zertifizierung mbH | Albrechtstraße 16 | D-52229 Berlin | www.din-certco.de

DIN CERTCO
Institution für Zertifizierung

ZERTIFIKAT

Zertifizierter: EMPUR Produktionsgesellschaft mbH
Industriepark Nord 60
53567 Buchholz
DEUTSCHLAND

Produkt: Raumflächenintegrierte Heiz- und Kühlsysteme
Fußböden, Decken und Wänden

Typ, Modell: PUR-FC009 11

Prüfgrundlage(n): DIN EN 1294-2:2013-08
DIN EN 1294-3:2009-11
DIN EN 1294-4:2009-11
Zertifizierungsprogramm Raumflächenintegrierte
Wasserschleife in (2009-11)

Konformitätszeichen: 

Registernummer: 3V216-F

Gültig bis: 2024-11-30

Nutzungsrecht: Dieses Zertifikat berechtigt zum Führen des oben stehenden Konformitätszeichens in Verbindung mit der genannten Registernummer.
Weitere Angaben siehe Anhang.

2024-11-28
Dipl.-Ing. Katharina Vehrung, M. Eng.
Zertifizierungsstelle



DAKS
Deutsches Institut für
Zertifizierung

DIN CERTCO Institution für Zertifizierung mbH | Albrechtstraße 16 | D-52229 Berlin | www.din-certco.de

DIN CERTCO
Institution für Zertifizierung

ZERTIFIKAT

Zertifizierter: EMPUR Produktionsgesellschaft mbH
Industriepark Nord 60
53567 Buchholz
DEUTSCHLAND

Produkt: Raumflächenintegrierte Heiz- und Kühlsysteme mit Wasserschleife in
Fußböden, Decken und Wänden

Typ, Modell: Top-Nepp PE 4T 15

Prüfgrundlage(n): DIN EN 1294-2:2013-08
DIN EN 1294-3:2009-11
DIN EN 1294-4:2009-11
Zertifizierungsprogramm Raumflächenintegrierte Heiz- und Kühlsysteme mit
Wasserschleife in (2009-11)

Konformitätszeichen: 

Registernummer: 3V243-F

Gültig bis: 2025-06-30

Nutzungsrecht: Dieses Zertifikat berechtigt zum Führen des oben stehenden Konformitätszeichens in Verbindung mit der genannten Registernummer.
Weitere Angaben siehe Anhang.

2025-06-28
Dipl.-Ing. Katharina Vehrung, M. Eng.
Zertifizierungsstelle



DAKS
Deutsches Institut für
Zertifizierung

DIN CERTCO Institution für Zertifizierung mbH | Albrechtstraße 16 | D-52229 Berlin | www.din-certco.de

16.5 General Terms and Conditions

General conditions of sale and delivery for EMPUR® Produktions GmbH, last revised: 2019, January

- Section 1**
Scope of Application
 Each and every contract is concluded solely and exclusively on the basis of the General Terms and Conditions of Sale, Supply and Payment of EMPUR®. EMPUR® does not accept the Buyer's contrary or deviating terms and conditions unless EMPUR® has expressly agreed to their application in writing. EMPUR®'s terms and conditions of sale apply even if delivery is made to the Buyer without reservation in awareness of Buyer's contrary or deviating terms and conditions of purchasing. EMPUR®'s General Terms and Conditions of Sale, Supply and Payment apply to any future transactions with the Buyer even if no express reference to their application is made during the conclusion of future contracts.
- Section 2: Conclusion and Content of Contract**
- EMPUR®'s sales offers are subject to change. The Buyer is required to submit an order within a period of 4 weeks. The contract is concluded by EMPUR®'s issue of an order confirmation within this period or by a delivery undertaken immediately in response to the order. The requirement of written form is satisfied by the transmission of order confirmations using web-based technology and/or fax. Oral agreements or oral modifications of or amendments to orders are not legally effective unless expressly confirmed in writing by EMPUR®. EMPUR® is entitled to give notification in its order confirmation of any deviations from the order which the Buyer can reasonably be expected to accept. Any such deviations become binding on both Parties unless the Buyer submits written objection to the content of the order confirmation no later than 12 days after its dispatch. In the event such objection is raised, EMPUR® is entitled to cancel the contract by sending a written statement to this effect within a further period of 12 days; any and all claims to damage compensation are excluded.
 - Rescheduling of an order which has effectively been concluded is possible only by mutual agreement.
 - EMPUR® is entitled to immediately cancel the contract, in whole or in part:
 - If and when the effects of force majeure (natural disaster, civil unrest, war, government actions, transport disruptions, strikes, lock-outs, operational disruptions) interfere long-term with fulfilment of the contract;
 - If and when EMPUR® does not receive supplies from its own suppliers and is not accountable for the supply failure;
 - If and when a petition for the initiation of bankruptcy proceedings (or equivalent proceedings according to local law) against the Buyer's assets is filed.
- Section 3: Place of Performance**
- The supply and shipment of the goods is made from EMPUR®'s company headquarters. The Buyer will be billed costs for freight, packaging, shipping and unloading only for a net product value of less than €3,950.00 unless the Parties have otherwise agreed.
 - EMPUR® is entitled to make partial deliveries and to issue separate invoices for such deliveries.
 - EMPUR® will package the goods properly.
 - The regulations of the INCOTERMS as most recently revised (EXW) apply as a supplement to deliveries outside of Germany.
- Section 4: Delivery Period**
- Compliance with agreed delivery times presumes the receipt in good time of any and all documents, necessary permits and releases to be provided by the Buyer, in particular, but not limited to, plans, as well as the Buyer's compliance with the agreed terms and conditions of payment. If these prerequisites are not fulfilled in good time, the delivery times will be extended by a reasonable period unless EMPUR® is accountable for the delays.
 - The day on which the Seller gives notification of the readiness of the purchased goods for shipping is authoritative for determining that the delivery is in good time. If and when the goods are not accepted in due time through the Buyer's fault, EMPUR® may at its discretion, after setting a subsequent period of 10 days, either request immediate payment of the purchase price without regard for any agreed credit line (arrears invoice) or cancel the contract and request damages for non-fulfilment.
 - Agreed delivery periods will be extended by a reasonable period in cases of force majeure, industrial actions and other operational disruptions for which EMPUR® is not accountable or in cases of delay in the delivery of essential preliminary materials if the hindrance continues for more than one week. The delivery period will be extended by the duration of the hindrance, but by no longer than 8 weeks plus subsequent delivery period. EMPUR® is obligated to notify the Buyer without delay of the reason for the hindrance as soon as it can be seen that compliance with the agreed delivery periods will not be possible. If a hindrance continues for a period in excess of 5 weeks, both of the Parties have the right to cancel the contract. However, the Buyer's right to cancel the contract must be announced in writing no less than 2 weeks before it is exercised.
- Section 5. Subsequent Delivery Period and Damage Caused by Delay**
- Upon expiration of the agreed delivery period, a subsequent delivery period of 14 days will commence without further declaration, unless the provisions of Section 4 (3) apply. Upon expiration of this subsequent delivery period, the Buyer is entitled to set in writing a subsequent period of 4 weeks for EMPUR®. Upon expiration of this period, the Buyer is entitled to withdraw from the contract, provided that it has announced this intention when setting the subsequent period. If no such statement was made when the subsequent period was set, EMPUR® will, at its discretion, be released from the obligation to make delivery upon expiration of this period if and when the Buyer has not stated, upon being asked, within the subsequent period whether it insists on fulfilment of the contract.
 - No fixed-date transactions are concluded.
 - EMPUR® is liable for damage or loss claimed by the Buyer in the event of delays in delivery, including claims for the reimbursement of expenses pursuant to Section 284 BGB [German Civil Code], only if and when it caused the delay in delivery through wilful intent or gross negligence. The above exclusion of liability does not apply in cases of injury to life, body or health, of breach of legally binding warranties and of fraudulent behaviour and gross culpability. In all other respects, compensation claims based on the breach of material obligations of the contract are limited to the foreseeable damage or loss typical of the contract and to 50% of the foreseeable damage or loss in cases of slight negligence unless the possibility of a greater damage or loss was pointed out to EMPUR® at the time the order was placed.
- Section 6: Acceptance Obligation**
 If the Buyer does not accept the goods, announces its refusal to accept before delivery is made or returns delivered goods without justification, or if EMPUR® is entitled to refuse delivery in accordance with Section 11, EMPUR® has the right to request that the Buyer fulfil the contract within a period of 12 days. The Buyer bears the costs incurred for storage, insurance and any other protective measures resulting from the delay in acceptance. EMPUR® is entitled to bill these costs in the lump-sum amount of 0.5% of the order value for each and every week of delay, limited, however, in the aggregate to 5% of the order value. Upon expiration of this period, EMPUR® is entitled to dispose otherwise of the goods and to bill the suffered loss or damage as a lump sum of 33% of the agreed purchase price or, at its discretion, to assert the loss in earnings which it has verifiably actually suffered. The Buyer is entitled to prove that loss or damage actually suffered was lower.
- Section 7: Examination for Defects**
- The Buyer is obligated to inspect the goods immediately after their receipt and to submit notification of any defects – including the delivery of goods in deviation from the order – within a preclusion period of 7 days after receipt of the goods. In the event of hidden defects, the period commences upon their discovery. EMPUR®'s field representatives are not authorised to accept complaints of defects. Upon expiration of the period, any complaints – including recourse pursuant to Section 478 BGB – are excluded. The above provision also applies in cases in which the Buyer has modified the delivered goods.
- Section 8: Liability for Defects**
- Deviations in quality, dimensions or weights that are usual in trade or technically unavoidable do not qualify as defects. Manufacturer's public statements, promotions or advertising do not qualify as agreements regarding characteristics.
 - If and when the Buyer has proved that it fulfilled its obligations pursuant to Section 377 HGB [German Commercial Code], EMPUR® has the right, at its discretion, in cases of legitimate complaints to carry out subsequent improvement or substitute delivery. EMPUR® is entitled to subsequent performance within a period of 2 months after return of the defective purchased goods. The Buyer's warranty rights are forfeit if and when, in the event of a complaint, it does not make the goods available to EMPUR® despite the latter's express request within a period of 10 days. If and when the subsequent performance has failed, the Buyer is entitled either to cancel the contract or to reduce the purchase price; this option is limited, however, to the goods about which complaint was made.
 - There are no claims due to material defects for natural wear and tear of the purchased goods or due to damage occurring after the passing of risk as a consequence of incorrect or negligent handling, overuse or unsuitable operating materials or arising from unusual external influences that were not foreseen in the contract. If the Buyer or third parties undertake improper modifications or repair work, there are also no claims due to defects for these and the resulting consequences. The following circumstances also result in the exclusion of warranty and liability claims:
 - Improper use of the purchased goods
 - Improper installation, commissioning, operation and maintenance of the purchased goods
 - Failure to observe the information in the operating instructions regarding transport, storage, installation, commissioning, operation, maintenance
 - Unauthorised construction changes
 - Effects of force majeure
 - If the complaint of defects proves to be unjustified, the Buyer is obligated to reimburse any expenditures incurred by the complaint (transport costs, inspection costs etc.).
 - If the Buyer has installed the defective product in another object or attached it to another object in accordance with its character and intended purpose, EMPUR® is entitled to point out to the Buyer the reimbursement for expenses pursuant to Section 439 (3) BGB in addition to the liability for the defective purchased product. Reworking by the Seller instead is subject to agreement. The expenses within the sense of Section 439 (3) BGB do not include the costs that result because parts that do not belong to the delivered product are destroyed, in whole or in part, during the installation and removal, unless it can be proved that the Seller acted culpably within the sense of wilful intent or gross negligence.
 - In the event that the costs for subsequent improvement are unreasonable, EMPUR® is entitled to refuse to carry out the subsequent performance or the type of subsequent performance as well as the claim to reimbursement of expenses pursuant to Section 439 (4) BGB.
 - If transport, road, labour and material costs increase because the purchased product has been conveyed to a site other than the contractually agreed destination, the resulting increase in the expenses will not be borne by EMPUR®.
 - There are no warranty claims for parts subject to wear and tear.
 - The warranty period for new goods is 1 year as of the passing of risk. This period is a limitation period and also applies to the assertion of loss or damage which did not occur to the supplied goods themselves, presuming that any liability at all pursuant to Subsection 4 is to be assumed. Claims for actions in tort or for allegations of bad faith on the part of EMPUR® are subject to statutory limitation periods. There is a warranty for used or restored products solely if such a warranty has been specifically agreed; otherwise, any such warranty is excluded. If legal provisions prescribe longer warranty periods (e.g. Section 438 BGB), these periods apply.
 - In the event of legitimate complaints due to defects, the Buyer may retain payments solely in a scope that is in a reasonable relationship to the defects that have occurred and the subsequent improvement costs required for the remedy. If and when payment obligations beyond this scope are not fulfilled:

16.5 General Terms and Conditions

- EMPUR® is entitled to refuse subsequent performance until payment of the legitimate claim has been made;
- Regress claims in accordance with Section 478 BGB are excluded.

11. The Seller is liable additionally, pursuant to the provisions governing contracts for works in the BGB, for defects in the milling and installation work (laying of heating pipes and installation of the distributor) carried out by the affiliated company EM-solution within the framework of the CUT-THERM® modernisation. Liability for defects is excluded or restricted in the event of a breach by the end customer (heating engineer or installer) of the "General Notes and Information for the End Customer" provided to it by the Seller.

Section 9: Limitation of Liability

If and when EMPUR®'s subsequent performance fails, the Buyer is not entitled to the assertion of any claims, regardless of the legal basis (including provisions concerning actions in tort), in excess of the rights pursuant to Section 437, nos. 2 and 3 BGB. EMPUR® is not liable for damage or loss which did not occur to the goods themselves or for lost profit or other pecuniary losses of the Buyer. To the extent that EMPUR®'s liability is excluded or limited, said exclusion or limitation also applies to the personal liability of its management, its permanent employees, worker representatives and vicarious agents. The indemnification from liability does not apply to injury to life, body or health; if and when loss or damage has been caused wilfully or through gross negligence; or, if EMPUR® has assumed a warranty of characteristics, or EMPUR® can be blamed for fraudulent behaviour. Moreover, it does not apply to claims asserted pursuant to Sections 1 and 4 of the German Product Liability Act. If and when EMPUR® is in breach of a cardinal obligation or other material obligation of the contract due to negligence, the compensation obligation is limited to the foreseeable damage or loss typical of the contract and to 50% of the foreseeable damage or loss in cases of slight negligence.

Section 10: Payment

- The invoice will be issued on the day of delivery or when the goods are made available. Invoices are payable net within 30 days. The Buyer is entitled to deduct a cash discount of 3% if payment is made within 8 days of the issue of the invoice and to deduct a cash discount of 2% if payment is made within 14 days of the issue of the invoice.
- If and when EMPUR® shows the prices in foreign currency, they will not be affected by changes in the official exchange rate of the euro to the foreign currency. Payment in these cases must be made in the foreign currency and in the amount of the invoice. Bills of exchange or cheques are accepted only on account of performance.
- When payment is made by cheque, the date of the redemption of the cheque is authoritative; when payment is made by bank transfer, the date the payment is credited to EMPUR®'s account is authoritative.
- Payments are always attributed to settlement of the oldest due claim plus any default interest which has accrued to this claim.
- EMPUR®'s prices are shown excluding legally applicable VAT. VAT in the statutory amount will be itemised in the invoice on the day of the issue of the invoice.
- For transactions outside Germany, the purchase price must be paid in advance before shipment/provision of the goods.

Section 11: Default of Payment

- In the event of default of payment, EMPUR® is entitled to charge default interest in the amount of 9 percentage points over the base lending rate or to request compensation for verifiably higher loss or damage owing to the default.
- EMPUR® has the additional rights shown below in the event of default of payment caused by exceeding the granted credit line:
 - EMPUR® is entitled to refuse to make further deliveries pursuant to current contracts. Delivery periods for current contracts which have not been fulfilled will be suspended, without specific notice, retroactively as of the time from the default of payment until full payment has been made.
 - EMPUR® is entitled to request immediate payment before delivery of the goods for any outstanding deliveries from any and all current contracts, any agreed credit lines notwithstanding.
 - EMPUR® is entitled to exercise the rights agreed in Section 13 (securing retention of title) and/or to cancel, in whole or in part, any and all current contracts.
- EMPUR® is also entitled to the above-mentioned rights if a significant worsening of the Buyer's financial position occurs (e.g. suspension of payment to other parties, petition for bankruptcy, execution measures, protests to cheques or bills of exchange, closing of business).
- In the event of default of payment, the Buyer must bear any and all costs and fees incurred by EMPUR®. Moreover, the Buyer must bear any and all costs EMPUR® incurs for the engagement of a German or foreign lawyer, including a correspondence lawyer.

Section 12: Offset and Retention

The Buyer may offset counterclaims only if and when they are undisputed or have been finally adjudicated. The above provision also applies to a right of retention, provided that the Buyer is a merchant. If this is not the case, a right of retention may be asserted only if and when the counterclaim arises from the same contractual relationship.

Section 13: Securing of Retention of Title

- EMPUR® retains title of ownership to the goods (reserved goods) until full payment of any and all claims from the delivery of goods from the entire business relationship, including subsidiary claims, damage compensation claims and the redemption of cheques and bills of exchange. The retention of title also remains effective if and when individual claims have been assimilated into a current invoice and the balance has been determined and acknowledged.
- Any processing or working undertaken by the Buyer is done on behalf of EMPUR®, but does not establish any obligations on EMPUR®. If and when reserved goods are processed, used and mixed with other goods that do not belong to EMPUR®, EMPUR® is entitled to a share of co-ownership in the new product in the ratio of the invoice value to the other processed

goods at the time of the processing, use or mixture. If the Buyer acquires sole ownership of the new product, the Parties are in agreement that the Buyer will grant to EMPUR® a share of co-ownership in the new product in the ratio of the invoice value of the processed, combined or mixed reserved goods and will safeguard the new goods on EMPUR®'s behalf free of charge.

- The Buyer is entitled to resell the goods in the ordinary course of its business. However, it assigns here and now any claims, including any and all subsidiary rights, arising from the resale of the reserved goods. EMPUR® accepts this assignment. The Buyer remains authorised to collect the assigned claims.
- The Buyer is not authorised to utilise the reserved goods within the scope of global assignments to financing institutes or similar institutions or to pledge or assign them by way of security in any other fashion. The Buyer shall notify EMPUR® immediately in writing of any attachments or other seizures by third parties so that it is in a position to assert its rights in accordance with Section 771 ZPO [German Civil Procedure]. If and when the third party is not able to reimburse EMPUR® for court and out-of-court costs of a suit in accordance with Section 771 ZPO, the Buyer is liable for any loss or damage that is suffered.
- In the event of breach of contract by the Buyer, in particular in case of default of payment, EMPUR® is entitled to cancel the contract and to take back the purchased goods. The Buyer agrees to this condition here and now. After reclaiming possession of the purchased goods, EMPUR® is entitled to utilise them, whereby the resulting loss or damage may be billed in accordance with Section 6.
- If and when the value of EMPUR®'s collateral exceeds that of its claims by more than 20%, EMPUR® will, upon petition by the Buyer, release the excess collateral at its discretion.

Section 14: Industrial Property Rights and Copyrights, Life Cycle Management Act

- A review of any documents provided by the Buyer (templates, samples etc.) to determine whether they are subject to any third-party rights, in particular, but not limited to, copyrights and industrial property rights, is the sole and exclusive responsibility of the Buyer. If and when claims pursuant to any such rights are asserted against the Supplier, the Buyer is obligated to compensate the Supplier for any and all loss or damage suffered by the latter as a consequence.
 - Unless otherwise agreed, the Supplier is obligated to perform the delivery free of any and all third-party industrial property rights and copyrights (hereinafter: intellectual property rights) solely in the country of the delivery destination. If and when a third party asserts legitimate claims against the Buyer pursuant to an infringement on intellectual property rights by products delivered by the Supplier and used in accordance with the contract, the Supplier is liable within the period defined in Section VII (3) as follows:
 - The Supplier will, at its discretion and at his own expense, either obtain a utilisation right for the pertinent product, modify the product so that it no longer infringes on the intellectual property right or replace the product. If this is not possible under conditions that are reasonable for the Supplier, the Buyer is entitled to statutory rights of cancellation of the contract or reduction of the purchase price.
 - The Supplier's obligations described above apply to relationships between entrepreneurs solely if and when the Buyer notifies the Supplier without delay in writing about the claims asserted by the third party and does not acknowledge any infringement and any and all defence measures and settlement negotiations remain the sole responsibility of the Supplier.
 - If and when the Buyer suspends use of the products for the purpose of minimising loss or damage or for other good reasons, it is obligated to notify the third party that the suspension of the use of the products does not entail any acknowledgement of any infringement of intellectual property rights.

Section 15: Proper Law

- The Parties agree that any and all legal transactions will be governed by the laws of Germany. The application of the provisions of the UN Uniform Law on the International Sale of Goods for Movable Items is expressly excluded.
- If and when goods are exported, EMPUR® is responsible for compliance with the relevant German legal provisions. Observance and performance of the relevant foreign trade legal provisions (e.g. import licences, currency transfer permits etc.) and any and all other laws applicable outside of Germany, including, but not limited to, those of the destination country, fall within the Buyer's purview.

Section 16: Venue

If and when the Buyer is a merchant, the agreed venue for any disputes, including those related to bills of exchange and cheques, is the court having local jurisdiction for EMPUR®'s company headquarters Linz on the Rhine. However, EMPUR® is also entitled to file suit against the Buyer at the latter's registered place of business.

Section 17: Severability and Subsidiary Agreements

- If and when individual provisions of this contract, in whole or in part, should be invalid or later become invalid, the validity of the remaining provisions of the contract will not be affected. The above provision also applies if it is determined that there is an omission in the regulations of the contract. In lieu of the invalid or unenforceable provisions or to remedy the omission, a regulation will be deemed agreed that corresponds most closely in legally permissible form to the commercial intent of the invalid or unenforceable provision or, in the case of an omission, that takes into account the provision that the Parties would have wanted (in accordance with the sense and purpose of the contract) if they had considered the point at the time of the conclusion of the contract or the later addition of a provision.
- Subsidiary agreements with persons whose representation authority for EMPUR® is not shown in the Commercial Register are invalid unless EMPUR® expressly confirms them in writing.
- Oral subsidiary agreements are not valid.

16.6 Numerical item index

Item No. Page Short name

002006	18	Insulation panel PUR 20mm WLS 024
003006	18	Insulation panel PUR 30mm WLS 024
004006	18	Insulation panel PUR 40mm WLS 024
004706	18	Insulation panel PUR 47mm WLS 024
005306	18	Insulation panel PUR 53mm WLS 024
011035	15	Floor insul. panel EPS-DEO tN11 WLS 035
011065	18	Floor insul. panel EPS-DEO 10mm WLS 032
012000	18	Sound insul. panel EPS-DES 20-2 WLS 045
012035	18	Floor insul. panel EPS-DEO 20mm WLS 035
012065	18	Floor insul. panel EPS-DEO 20mm WLS 032
012500	18	Sound insul. panel EPS-DES 25-2 WLS 045
013000	18	Sound insul. panel EPS-DES 30-3 WLS 045
013015	15	Sound insul. panel EPS-DES 30-2 WLS 040
013015	18	Sound insul. panel EPS-DES 30-2 WLS 040
013035	17	Floor insul. panel EPS-DEO 30mm WLS 035
013035	18	Floor insul. panel EPS-DEO 30mm WLS 035
013045	18	Floor insul. panel EPS-DEO 30mm WLS 040
013065	18	Floor insul. panel EPS-DEO 30mm WLS 032
013500	18	Sound insul. panel EPS-DES 35-3 WLS 045
014035	18	Floor insul. panel EPS-DEO 40mm WLS 035
014065	18	Floor insul. panel EPS-DEO 40mm WLS 032
015035	18	Floor insul. panel EPS-DEO 50mm WLS 035
015045	18	Floor insul. panel EPS-DEO 50mm WLS 040
015065	18	Floor insul. panel EPS-DEO 50mm WLS 032
016035	18	Floor insul. panel EPS-DEO 60mm WLS 035
016045	18	Floor insul. panel EPS-DEO 60mm WLS 040
016065	18	Floor insul. panel EPS-DEO 60mm WLS 032
022010	11	Composite panel "Objekt" EPS-DES 20-2
022012	11	Turbo-Cube EPS-DES 20-2
022060	11	Composite panel "Kompakt" EPS-DEO 20
022510	11	Composite panel "Objekt" EPS-DES 25-2
022512	11	Turbo-Cube EPS-DES 25-2
022525	11	Composite panel V5 EPS-DES 25-2
023010	11	Composite panel "Objekt" EPS-DES 30-3
023012	11	Turbo-Cube EPS-DES 30-3
023020	11	Composite panel V5 EPS-DES 30-2
023022	11	Turbo-Cube V5 EPS-DES 30-2
023025	11	Composite panel V5 EPS-DES 30-2
023060	11	Composite panel "Kompakt" EPS-DEO 30
023510	11	Composite panel "Objekt" EPS-DES 35-3
023512	11	Turbo-Cube EPS-DES 35-3
030100	17	Dry construction load distribution element
030230	17	Hot cutting tool
030420	16	Dry construction system panel RA 12.5/25
030421	16	Dry construction aluminium baffle RA 12.5
030423	16	Dry constr. galvanised heat conduction plate
030424	16	Dry constr. aluminium heat conduction plate
031004	28	Ceiling element H/C aluminium
031005	28	Ceiling compensation element
031006	29	Ceiling and wall element H/C
031024	29	Ceiling and wall element H/C
031124	29	Ceiling and wall compensation element
031182	29	Push fitting H/C element alu 2
031184	29	Push fitting H/C element alu 4
031208	29	Plug for push fitting 8mm
031220	29	Plug for push fitting 20mm
031282	29	Push fitting H/C PE alu 2

Item No. Page Short name

031284	29	Push fitting H/C PE alu 4
032122	29	Push fitting H/C element coupling alu
032182	29	Push fitting H/C element alu 2
032184	29	Push fitting H/C element alu 4
032222	29	Push fitting H/C element coupling PE
032282	29	Push fitting H/C PE alu 2
032284	29	Push fitting H/C PE alu 4
032288	29	Push fitting H/C element coupling PE-RT
041400	10	Composite panel PUR/PE 14
042300	10	Composite panel PUR/PE 23
042400	10	Composite panel PUR 23
043150	10	Composite panel PUR/PE 36
043400	10	Composite panel PUR 33
044000	10	Composite panel PUR 40
046350	10	Composite panel PUR/PE 68
070001	13	Connecting tape "Klett"
070220	12	Composite panel "Klett" EPS-DES 20-2
070232	12	Composite panel "Klett" EPS-DES 30-2
070236	13	Comp. panel "Klett-Kompakt" EPS-DEO 30
070320	12	Turbo-Cube 20-2 "Klett"
070325	12	Turbo-Cube 25-2 "Klett"
070330	12	Turbo-Cube 30-3 "Klett"
070332	12	Turbo-Cube 30-2 "Klett"
070335	12	Turbo-Cube 35-3 "Klett"
070414	12	Composite panel PUR/PE 15 "Klett"
070424	12	Composite panel PUR 23 "Klett"
070503	13	Fiberboard "Klett" 2.6
071211	13	Heating pipe PE-RT 12x1.5 "Klett"
071512	13	Heating pipe PE-RT 15x1.8 "Klett"
071516	13	Heating pipe PE-RT 15x1.8 "Klett"
071592	13	Heating pipe PE-Xa 15x1.8 "Klett"
071596	13	Heating pipe PE-Xa 15x1.8 "Klett"
071712	13	Heating pipe PE-RT 17x2 "Klett"
071715	13	Heating pipe PE-RT 17x2 "Klett"
071792	13	Heating pipe PE-Xa 17x2 "Klett"
071795	13	Heating pipe PE-Xa 17x2 "Klett"
080020	14	Castellated element top-Nopp
080021	14	Connector strips top-Nopp
080022	15	Door and levelling element top-Nopp
080047	15	Floor insul. panel EPS-DEO tN 11 WLS 035
080050	22	Castellated element top-Nopp mini 12
080051	22	Castellated element top-Nopp mini 15
081120	14	top-Nopp 11 base mat
083020	14	top-Nopp 30-2 base mat
089050	23	top-Nopp mini kit 12
089051	23	top-Nopp mini kit 15
089900	15	top-Nopp round section
092201	21	CUT-THERM HCM-D 1
092202	21	CUT-THERM HCM-D 2
092203	21	CUT-THERM HCM-D 3
092204	21	CUT-THERM HCM-D 4
092205	21	CUT-THERM HCM-D 5
092206	21	CUT-THERM HCM-D 6
092207	21	CUT-THERM HCM-D 7
092208	21	CUT-THERM HCM-D 8
092209	21	CUT-THERM HCM-D 9
092210	21	CUT-THERM HCM-D 10

Item No. Page Short name

092211	21	CUT-THERM HCM-D 11
092212	21	CUT-THERM HCM-D 12
092213	21	CUT-THERM HCM-D 13
092214	21	CUT-THERM HCM-D 14
092215	21	CUT-THERM HCM-D 15
092216	21	CUT-THERM HCM-D 16
092217	21	CUT-THERM HCM-D 17
092218	21	CUT-THERM HCM-D 18
092219	21	CUT-THERM HCM-D 19
092220	21	CUT-THERM HCM-D 20
092221	21	CUT-THERM HCM-D 21
092222	21	CUT-THERM HCM-D 22
092223	21	CUT-THERM HCM-D 23
092224	21	CUT-THERM HCM-D 24
092225	21	CUT-THERM HCM-D 25
092502	21	CUT-THERM HCM-DR 2
092503	21	CUT-THERM HCM-DR 3
092504	21	CUT-THERM HCM-DR 4
092505	21	CUT-THERM HCM-DR 5
092506	21	CUT-THERM HCM-DR 6
092507	21	CUT-THERM HCM-DR 7
092508	21	CUT-THERM HCM-DR 8
092509	21	CUT-THERM HCM-DR 9
092510	21	CUT-THERM HCM-DR 10
092511	21	CUT-THERM HCM-DR 11
092512	21	CUT-THERM HCM-DR 12
092513	21	CUT-THERM HCM-DR 13
092514	21	CUT-THERM HCM-DR 14
092515	21	CUT-THERM HCM-DR 15
092516	21	CUT-THERM HCM-DR 16
111231	7	Heating pipe PE-RT 12x1.5
111231	23	Heating pipe PE-RT 12x1.5
111231	26	Heating pipe PE-RT 12x1.5
111516	8	Heating pipe PE-RT 15x1.8
111532	7	Heating pipe PE-RT 15x1.8
111532	23	Heating pipe PE-RT 15x1.8
111532	26	Heating pipe PE-RT 15x1.8
111546	7	Heating pipe PE-RT 15x1.8
111552	8	Heating pipe PE-RT 15x1.8
111556	8	Heating pipe PE-RT 15x1.8
111715	8	Heating pipe PE-RT 17x2
111732	7	Heating pipe PE-RT 17x2
111745	7	Heating pipe PE-RT 17x2
111752	8	Heating pipe PE-RT 17x2
111755	8	Heating pipe PE-RT 17x2
112032	7	Heating pipe PE-RT 20x2
112044	7	Heating pipe PE-RT 20x2
171602	8	Metal composite pipe PE-RT 16x2
171602	17	Metal composite pipe PE-RT 16x2
171615	8	Metal composite pipe PE-RT 16x2
171615	17	Metal composite pipe PE-RT 16x2
191516	7	Heating pipe PE-Xa 15x1.8
191532	6	Heating pipe PE-Xa 15x1.8
191546	6	Heating pipe PE-Xa 15x1.8
191715	7	Heating pipe PE-Xa 17x2
191732	6	Heating pipe PE-Xa 17x2
191745	6	Heating pipe PE-Xa 17x2

16.6 Numerical item index

Item No.	Page	Short name	Item No.	Page	Short name	Item No.	Page	Short name
192014	7	Heating pipe PE-Xa 20x2	251012	44	Control station HCM-DR 10	270925	91	Industrial manifold HCM-D 9 25x2.3
192037	6	Heating pipe PE-Xa 20x2	251112	44	Control station HCM-DR 11	270925	95	Industrial manifold HCM-D 9 25x2.3
192044	6	Heating pipe PE-Xa 20x2	251212	44	Control station HCM-DR 12	271020	91	Industrial manifold HCM-D 10 20x2.0
192534	6	Heating pipe PE-Xa 25x2.3	251312	44	Control station HCM-DR 13	271020	95	Industrial manifold HCM-D 10 20x2.0
220141	40	Manifold expansion set brass HCM-D	251412	44	Control station HCM-DR 14	271025	91	Industrial manifold HCM-D 10 25x2.3
220176	38	Manifold expansion set nickel plated HCM-D	251512	44	Control station HCM-DR 15	271025	95	Industrial manifold HCM-D 10 25x2.3
220178	37	Manifold expansion set HCM-DB	251612	44	Control station HCM-DR 16	271120	91	Industrial manifold HCM-D 11 20x2.0
220246	40	Brass manifold HCM-D 2	267120	52	Manifold cabinet Economy, size 1 FM	271120	95	Industrial manifold HCM-D 11 20x2.0
220276	38	Stainless steel manifold HCM-D 2	267130	52	Manifold cabinet Economy, size 1 WM	271125	91	Industrial manifold HCM-D 11 25x2.3
220278	37	Stainless steel manifold HCM-DB 2	267220	52	Manifold cabinet Economy, size 2 FM	271125	95	Industrial manifold HCM-D 11 25x2.3
220346	40	Brass manifold HCM-D 3	267230	52	Manifold cabinet Economy, size 2 WM	271220	91	Industrial manifold HCM-D 12 20x2.0
220376	38	Stainless steel manifold HCM-D 3	267320	52	Manifold cabinet Economy, size 3 FM	271220	95	Industrial manifold HCM-D 12 20x2.0
220378	37	Stainless steel manifold HCM-DB 3	267330	52	Manifold cabinet Economy, size 3 WM	271225	91	Industrial manifold HCM-D 12 25x2.3
220446	40	Brass manifold HCM-D 4	267420	52	Manifold cabinet Economy, size 4 FM	271225	95	Industrial manifold HCM-D 12 25x2.3
220476	38	Stainless steel manifold HCM-D 4	267430	52	Manifold cabinet Economy, size 4 WM	271320	91	Industrial manifold HCM-D 13 20x2.0
220478	37	Stainless steel manifold HCM-DB 4	268120	48	Manifold cabinet Exclusiv, size 1	271320	95	Industrial manifold HCM-D 13 20x2.0
220546	40	Brass manifold HCM-D 5	268130	47	Manifold cabinet Top Standard, size 1	271325	91	Industrial manifold HCM-D 13 25x2.3
220576	38	Stainless steel manifold HCM-D 5	268140	49	Manifold cabinet Exclusiv super flat, size 1	271325	95	Industrial manifold HCM-D 13 25x2.3
220578	37	Stainless steel manifold HCM-DB 5	268220	48	Manifold cabinet Exclusiv, size 2	271420	91	Industrial manifold HCM-D 14 20x2.0
220646	40	Brass manifold HCM-D 6	268230	47	Manifold cabinet Top Standard, size 2	271420	95	Industrial manifold HCM-D 14 20x2.0
220676	38	Stainless steel manifold HCM-D 6	268240	49	Manifold cabinet Exclusiv super flat, size 2	271425	91	Industrial manifold HCM-D 14 25x2.3
220678	37	Stainless steel manifold HCM-DB 6	268320	48	Manifold cabinet Exclusiv, size 3	271425	95	Industrial manifold HCM-D 14 25x2.3
220746	40	Brass manifold HCM-D 7	268330	47	Manifold cabinet Top Standard, size 3	271520	91	Industrial manifold HCM-D 15 20x2.0
220776	38	Stainless steel manifold HCM-D 7	268340	49	Manifold cabinet Exclusiv super flat, size 3	271520	95	Industrial manifold HCM-D 15 20x2.0
220778	37	Stainless steel manifold HCM-DB 7	268420	48	Manifold cabinet Exclusiv, size 4	271525	91	Industrial manifold HCM-D 15 25x2.3
220846	40	Brass manifold HCM-D 8	268430	47	Manifold cabinet Top Standard, size 4	271525	95	Industrial manifold HCM-D 15 25x2.3
220876	38	Stainless steel manifold HCM-D 8	268440	49	Manifold cabinet Exclusiv super flat, size 4	271620	91	Industrial manifold HCM-D 16 20x2.0
220878	37	Stainless steel manifold HCM-DB 8	269125	51	Manifold cabinet Exclusiv, size 1	271620	95	Industrial manifold HCM-D 16 20x2.0
220946	40	Brass manifold HCM-D 9	269135	50	Manifold cabinet Top Standard-plus, size 1	271625	91	Industrial manifold HCM-D 16 25x2.3
220976	38	Stainless steel manifold HCM-D 9	269225	51	Manifold cabinet Exclusiv-plus, size 2	271625	95	Industrial manifold HCM-D 16 25x2.3
220978	37	Stainless steel manifold HCM-DB 9	269235	50	Manifold cabinet Top Standard-plus, size 2	280202	59	Compl. manifold HCM-G 2 FM brass
221046	40	Brass manifold HCM-D 10	269325	51	Manifold cabinet Exclusiv-plus, size 3	280203	59	Compl. manifold HCM-G 2 WM brass
221076	38	Stainless steel manifold HCM-D 10	269335	50	Manifold cabinet Top Standard-plus, size 3	280206	58	Compl. manifold HCM-G 2 FM stainless steel
221078	37	Stainless steel manifold HCM-DB 10	269425	51	Manifold cabinet Exclusiv-plus, size 4	280207	58	Compl. manifold HCM-G 2 WM stainless steel
221146	40	Brass manifold HCM-D 11	269435	50	Manifold cabinet Top Standard-plus, size 4	280302	59	Compl. manifold HCM-G 3 FM brass
221176	38	Stainless steel manifold HCM-D 11	269525	51	Manifold cabinet Exclusiv-plus, size 5	280303	59	Compl. manifold HCM-G 3 WM brass
221178	37	Stainless steel manifold HCM-DB 11	269535	50	Manifold cabinet Top Standard-plus, size 5	280306	58	Compl. manifold HCM-G 3 FM stainless steel
221246	40	Brass manifold HCM-D 12	270134	43	Line regulating valve STAD DN20	280307	58	Compl. manifold HCM-G 3 WM stainless steel
221276	38	Stainless steel manifold HCM-D 12	270135	43	Line regulating valve STAD DN25	280402	59	Compl. manifold HCM-G 4 FM brass
221278	37	Stainless steel manifold HCM-DB 12	270520	91	Industrial manifold HCM-D 5 20x2.0	280403	59	Compl. manifold HCM-G 4 WM brass
221341	40	Brass manifold HCM-D 13	270520	95	Industrial manifold HCM-D 5 20x2.0	280406	58	Compl. manifold HCM-G 4 FM stainless steel
221441	40	Brass manifold HCM-D 14	270525	91	Industrial manifold HCM-D 5 25x2.3	280407	58	Compl. manifold HCM-G 4 WM stainless steel
221541	40	Brass manifold HCM-D 15	270525	95	Industrial manifold HCM-D 5 25x2.3	280502	59	Compl. manifold HCM-G 5 FM brass
221641	40	Brass manifold HCM-D 16	270620	91	Industrial manifold HCM-D 6 20x2.0	280503	59	Compl. manifold HCM-G 5 WM brass
230032	45	Passageway connection set	270620	95	Industrial manifold HCM-D 6 20x2.0	280506	58	Compl. manifold HCM-G 5 FM stainless steel
230042	45	90° connection set	270625	91	Industrial manifold HCM-D 6 25x2.3	280507	58	Compl. manifold HCM-G 5 WM stainless steel
230053	59	Thermoseparator 5/4" brass	270625	95	Industrial manifold HCM-D 6 25x2.3	280602	59	Compl. manifold HCM-G 6 FM brass
230054	59	Thermoseparator 1" stainless steel	270720	91	Industrial manifold HCM-D 7 20x2.0	280603	59	Compl. manifold HCM-G 6 WM brass
233434	42	Flow meter	270720	95	Industrial manifold HCM-D 7 20x2.0	280606	58	Compl. manifold HCM-G 6 FM stainless steel
250212	44	Control station HCM-DR 2	270725	91	Industrial manifold HCM-D 7 25x2.3	280607	58	Compl. manifold HCM-G 6 WM stainless steel
250312	44	Control station HCM-DR 3	270725	95	Industrial manifold HCM-D 7 25x2.3	280702	59	Compl. manifold HCM-G 7 FM brass
250412	44	Control station HCM-DR 4	270820	91	Industrial manifold HCM-D 8 20x2.0	280703	59	Compl. manifold HCM-G 7 WM brass
250512	44	Control station HCM-DR 5	270820	95	Industrial manifold HCM-D 8 20x2.0	280706	58	Compl. manifold HCM-G 7 FM stainless steel
250612	44	Control station HCM-DR 6	270825	91	Industrial manifold HCM-D 8 25x2.3	280707	58	Compl. manifold HCM-G 7 WM stainless steel
250712	44	Control station HCM-DR 7	270825	95	Industrial manifold HCM-D 8 25x2.3	280802	59	Compl. manifold HCM-G 8 FM brass
250812	44	Control station HCM-DR 8	270920	91	Industrial manifold HCM-D 9 20x2.0	280803	59	Compl. manifold HCM-G 8 WM brass
250912	44	Control station HCM-DR 9	270920	95	Industrial manifold HCM-D 9 20x2.0	280806	58	Compl. manifold HCM-G 8 FM stainless steel

16.6 Numerical item index

Item No. Page Short name

280807	58	Compl. manifold HCM-G 8 WM stainless steel
280902	59	Compl. manifold HCM-G 9 FM brass
280903	59	Compl. manifold HCM-G 9 WM brass
280906	58	Compl. manifold HCM-G 9 FM stainless steel
280907	58	Compl. manifold HCM-G 9 WM stainless steel
281002	59	Compl. manifold HCM-G 10 FM brass
281003	59	Compl. manifold HCM-G 10 WM brass
281006	58	Compl. manifold HCM-G 10 FM stainless steel
281007	58	Compl. manifold HCM-G 10 WM stainless steel
281102	59	Compl. manifold HCM-G 11 FM brass
281103	59	Compl. manifold HCM-G 11 WM brass
281106	58	Compl. manifold HCM-G 11 FM stainless steel
281107	58	Compl. manifold HCM-G 11 WM stainless steel
281202	59	Compl. manifold HCM-G 12 FM brass
281203	59	Compl. manifold HCM-G 12 WM brass
281206	58	Compl. manifold HCM-G 12 FM stainless steel
281207	58	Compl. manifold HCM-G 12 WM stainless steel
281302	59	Compl. manifold HCM-G 13 FM brass
281303	59	Compl. manifold HCM-G 13 WM brass
281402	59	Compl. manifold HCM-G 14 FM brass
281403	59	Compl. manifold HCM-G 14 WM brass
281502	59	Compl. manifold HCM-G 15 FM brass
281503	59	Compl. manifold HCM-G 15 WM brass
290114	42	Manifold connection set passageway 5/4"
291100	42	Manifold connection set 90°
295100	42	Manifold connection set passageway 1/4"
301400	31	Press-fit coupling 14x2
301500	31	Press-fit coupling 15x1.8
301600	31	Press-fit coupling 16x2
301700	31	Press-fit coupling 17x2
302000	31	Press-fit coupling 20x2
302500	31	Press-fit coupling 25x2.3
351500	31	Adapter nipple 15x1.8
361500	31	Adapter nipple 15x1.8
361600	31	Adapter nipple 16x2
361700	31	Adapter nipple 17x2
362000	31	Adapter nipple 20x2
362500	31	Adapter nipple 25x2.3
371503	31	Connection bracket 90° 15x1.8
371513	31	Connection T-piece 15x1.8
371703	31	Connection bracket 90° 17x2
371713	31	Connection T-piece 17x2
401010	30	Connection coupling 10x1.3 brass
401211	23	Connection coupling 12x1.5 brass
401211	27	Connection coupling 12x1.5 brass
401211	30	Connection coupling 12x1.5 brass
401500	23	Connection coupling 15x1.8 brass
401500	27	Connection coupling 15x1.8 brass
401500	30	Connection coupling 15x1.8 brass
401600	30	Connection coupling 16x2 brass
401700	30	Connection coupling 17x2 brass
402000	30	Connection coupling 20x2 brass
402500	30	Connection coupling 25x2.3 brass
421000	30	Compression fitting 10x1.3 brass
421211	23	Compression fitting 12x1.5 brass
421211	27	Compression fitting 12x1.5 brass
421211	30	Compression fitting 12x1.5 brass
421500	23	Compression fitting 15x1.8 brass

Item No. Page Short name

421500	27	Compression fitting 15x1.8 brass
421500	30	Compression fitting 15x1.8 brass
421501	30	Compression fitting 15x1.8 brass
421700	30	Compression fitting 17x2 brass
421701	30	Compression fitting 17x2 brass
422000	30	Compression fitting 20x2 brass
422001	30	Compression fitting 20x2 brass
452500	31	Screw connection 25x2.3
461400	31	Screw connection 14x2
461500	31	Screw connection 15x1.8
461700	31	Screw connection 17x2
462000	31	Screw connection 20x2
462500	31	Screw connection 25x2.3
510621	45	Overheat thermostat
510705	45	Contemp alpha 25
520026	93	Zone valve
520027	43	Zone valve
520030	45	Actuator control set V
520040	45	Thermostatic head control set K
521001	43	Balancing valve
550101	70	DDC Actuator 24V
552309	70	Economy Actuator 230V
552310	70	Economy Actuator 24V
553120	70	Man Open Actuator 230V
553140	70	Man Open Actuator 24V
560301	81	Dew point monitor 230V
560302	81	Dew point sensor type 2
560303	81	Dew point sensor type 3
572060	69	Geniux installation server
572061	68	Geniux configuration KNX
572065	68	Geniux configuration <50
572066	68	Geniux configuration <100
572067	68	Geniux configuration >100
572070	61	Geniux complete electric manifold FM
572071	61	Geniux complete electric manifold FM
572072	61	Geniux complete electric manifold FM
572073	61	Geniux complete electric manifold FM
572074	61	Geniux complete electric manifold WM
572081	69	Travel expenses
572083	61	Geniux complete electric manifold WM
572084	61	Geniux complete electric manifold WM
572307	71	Room operating unit 24V display heating
572308	71	Room operating unit 230V display heating
572333	72	Regulator terminal strip 6 zones 230V
572334	72	Regulator terminal strip 10 zones 230V
572343	72	Regulator terminal strip 6 zones 24V
572344	72	Regulator terminal strip 10 zones 24V
572890	72	Cover frame white
572890	75	Cover frame white
572890	79	Cover frame white
572890	80	Cover frame white
573021	24	FM control set variant 1
573031	24	FM control set variant 2
574101	74	Room operat. unit 230V analog. heat./cool.
574102	74	Room operat. unit 230V display heat./cool.
574103	71	Room operating unit 230V analogue heating
574105	71	Room sensor 230V heating
574111	75	Regulator terminal strip 6 zones 230V

Item No. Page Short name

574112	75	Regulator terminal strip 10 zones 230V
574113	73	Balance control terminal strip heat./cool.
574131	74	Room operat. unit 24V analog. heat./cool.
574132	74	Room operat. unit 24V display heat./cool.
574133	71	Room operating unit 24V analogue heating
574141	75	Regulator terminal strip 6-zone 24V
574142	75	Regulator terminal strip 10-zone 24V
575001	80	Room operating unit BUS with display
575002	80	Room operating unit BUS without display
575003	80	Room sensor BUS
575042	80	Base station BUS 8-zone 24V
584022	74	Floor sensor
585001	79	Radio room operating unit with display
585002	79	Radio room operating unit without display
585003	79	Radio room sensor
585011	78	4-zone Ethernet base station
585012	78	8-zone Ethernet base station
585013	78	12-zone Ethernet base station
585014	77	4-zone radio base station
585015	77	8-zone radio base station
585016	77	12-zone radio base station
585017	77	1-zone radio base station
585020	81	Internal humidity monitor sensor
585021	81	External humidity monitor sensor
585022	81	Repeater
585023	81	External antenna
620060	43	Immersion thermometer indicator red
620062	43	Immersion thermometer indicator blue
620067	43	Contact thermometer
621400	33	Compression fitting 14x2 brass
621600	17	Compression fitting 16x2 brass
621600	33	Compression fitting 16x2 brass
720100	43	Manifold crosspiece
720134	43	Immersion sleeve
721017	42	WMZ connection set passageway 1/2"
721027	42	WMZ connection set passageway 3/4"
721037	42	WMZ connection set 90° 1/2"
721047	42	WMZ connection set 90° 3/4"
721100	43	Connector piece
722002	42	Ball valve 3/4" nickel-plated
722002	45	Ball valve 3/4" nickel-plated
790111	30	Sealing cap
790112	30	Sealing cap nickel-plated
791010	43	Reducer 5/4" x 1"
791012	43	Reducer 1" x 1/2"
791034	43	Reducer 1" x 3/4"
791112	43	Reducer 5/4" x 1/2"
793435	31	Double nipple brass
793440	31	Double nipple brass
900010	33	Retaining dowel
900015	33	Film dowel
900020	17	PE cover sheeting
900020	33	PE cover sheeting
900045	92	Mat connector 120
900046	92	Mat connector 180
900050	27	Dowel nail 6 mm
900051	27	Dowel clamp 6 mm
900053	27	Glass reinforcement fabric

Item No. Page Short name

900058	27	Wall heating kit 12m²
900059	27	Wall heating kit 20m²
900302	90	Bare pipe mat 100
900310	90	Bare pipe mat 150
901000	34	Screed additive
901002	33	Plastic grid film
901004	23	Expansion profile DF-P
901010	32	Expansion gap profile
901011	36	Notching pliers
901012	15	Expansion gap section top-Nopp
901014	27	Angle brace 90° 14mm, open
901014	33	Angle brace 90° 14mm, open
901418	27	Angle brace 90° 17mm, open
901418	33	Angle brace 90° 17mm, open
902000	34	Screed reinforcement fibre
902020	33	Angle brace 90° 20mm, open
902020	93	Angle brace 90° 20mm, open
902426	93	Angle brace 90° 25mm, open
902600	52	Top-hat rail
902600	75	Top-hat rail
902600	77	Top-hat rail
902600	78	Top-hat rail
902600	81	Top-hat rail
903200	32	PE film moisture barrier
903201	32	Bitumen sealant and adhesive
903202	32	Butyl sealing tape
903203	33	System connection strips
903204	32	Fixing tape
904000	34	Hard bed
904001	34	Hard bed, inorganic
905501	33	Plastic adhesive tape
908152	32	Edge insulation strips 8x150 mm
908154	32	Edge insulation strips 10x150 mm
908155	90	Edge insulation strips XXL Industry
908158	23	Edge insulation strips 5x50 selfadhesive
908159	17	Edge insulation strips 8x150 selfadhesive
908159	32	Edge insulation strips 8x150 selfadhesive
910027	35	Pipe cutter
910050	15	top-Nopp cutting tool
911000	11	Short staples
911000	32	Short staples
911001	11	Long staples
911001	32	Long staples
911202	26	Clip rail 8-12mm
911202	34	Clip rail 8-12mm
911502	26	Clip rail 15mm
911502	34	Clip rail 15mm
911602	34	Clip rail 16mm
911702	34	Clip rail 17mm
912000	92	Mounting clips 20mm
912002	93	Clip rail 20mm
912002	94	Clip rail 20mm
912502	93	Clip rail 25mm
912502	94	Clip rail 25mm
912506	92	Mounting clips 25mm
912508	92	Mounting clips 25mm
912800	33	Deflection curve 90°
914817	92	Pipe holder 4.8x170
914818	92	Pipe holder 7.8x290

Item No. Page Short name

914920	94	Pipe guide rail 20mm
914925	94	Pipe guide rail 25mm
918400	15	Expansion joint protective pipe 400mm slot.
918400	33	Expansion joint protective pipe 400mm slot.
918410	93	Expansion joint protective pipe 400mm slot.
918500	15	Expansion joint protective pipe 25m unslot.
918500	33	Expansion joint protective pipe 25m unslot.
918510	93	Expansion joint protective pipe 25m unslot.
918600	15	Expansion joint protective pipe 25m slotted
918600	33	Expansion joint protective pipe 25m slotted
918610	93	Expansion joint protective pipe 25m slotted
961014	36	Press jaw 14x2
961015	36	Press jaw 15x1.8
961016	36	Press jaw 16x2
961017	36	Press jaw 17x2
961020	36	Press jaw 20x2
961025	36	Press jaw 25x2.3
961116	17	Flexible spring, internal
961216	17	Flexible spring, external
961501	36	Calibrator 15x1.8
961601	36	Calibrator 16x2
961701	36	Calibrator 17x2
961720	36	Herz exchange tool
962001	36	Calibrator 20x2
962501	36	Calibrator 25x2.3
990046	92	Drill tool
990050	93	Binding machine Exclusiv
990051	93	Wire reel for binding machine
990052	93	Binding machine loan unit
990060	13	"Klett" gloves
990100	34	Marking set
990200	13	Door tensioner
990200	36	Door tensioner
990210	13	Ceiling tensioner
990210	36	Ceiling tensioner
990800	35	Pipe dispenser
991010	11	PUR-THERM System stapler
991010	35	PUR-THERM System stapler
991011	11	System stapler extension
991011	35	System stapler extension
992750	36	Trestles
995501	35	Hand dispenser
2097372	61	Geniax pump electronics
2097374	62	Geniax BUS coupler
2098646	65	Geniax reducer double nipple
2098647	62	Geniax power transformer 2,5A
2098649	65	Geniax compensation piece euro cone
2099206	62	Geniax power transformer 4,2A
2101230	64	Geniax design cover L
2101232	64	Geniax design cover M
2101233	65	Geniax immersion sleeve
2101235	65	Geniax flow temperature sensor
2101237	65	Geniax surface sensor
2101238	65	Geniax outside temperature sensor
2104098	64	Geniax design cover electronic
2104099	63	Geniax ambient sensor
2104100	63	Geniax basic control
2104104	63	Geniax Central Control
2105645	62	Geniax BACnet module

Item No. Page Short name

2107484	61	Geniax Pump 1.0
2115496	60	Geniax Adapter Set Inline
2115497	61	Geniax Adapter Set
2115498	65	Geniax Set NRV
2115889	65	Geniax Assembly aid
2115889	67	Geniax Assembly aid
2117408	64	Geniax Design Cover S
2117514	60	Geniax Adapter H-Inline
2117515	60	Geniax Adapter H-Angle
2117516	60	Geniax Adapter H-Angle
2120425	68	Geniax Configuration BACnet
2120426	69	Geniax Commissioning KNX/BACnet
2120428	69	Geniax support
2122546	63	Geniax Licence-key
2122547	63	Geniax Licence-key Pro
2125135	62	Geniax Server 2.0
2131230	63	Geniax Ambient Sensor i
2132766	65	Geniax BUS Tester
2132813	60	Geniax Adapter Set Corner right
2132814	60	Geniax Adapter Set Corner left
2132815	60	Geniax Adapter Set Corner right/left
2132816	60	Geniax Adapter Set Corner left/right
2132817	60	Geniax Adapter Set Angle right
2132818	60	Geniax Adapter Set Angle left
2132819	60	Geniax Adapter Set Angle right/left
2132820	60	Geniax Adapter Set Angle left/right
2132821	64	Geniax Design Cover MC
2132822	64	Geniax Design Cover SC
2137530	68	Geniax configuration UGW KNX/BACnet
2137532	62	Geniax KNX Coupler
2137533	62	Geniax UGW KNX
2137540	62	Geniax UGW KNX Extension
2137560	62	Geniax UGW BACnet
2139419	67	Heatfixx flush-mounted assembly set
2139420	67	Heatfixx wall-mounted assembly set
2140204	67	Heatfixx Adapter Inline, Cover M
2140205	67	Heatfixx Adapter Corner right, Cover MC
2140206	67	Heatfixx Adapter Corner left, Cover MC
2140207	67	Heatfixx Adapter H-Inline, Cover L
2140208	67	Heatfixx Adapter H-Angle right, Cover L
2140209	67	Heatfixx Adapter H-Angle left, Cover L
2145119	67	Heatfixx Adapter Angle right, Cover MC
2145120	67	Heatfixx Adapter Angle left, Cover MC
2901701	62	Geniax UGW KNX extension
2901702	62	Geniax UGW KNX extension
2901703	62	Geniax UGW KNX extension
2901704	62	Geniax UGW BACnet extension
2901705	62	Geniax UGW BACnet extension
2901706	62	Geniax UGW BACnet extension
99515001	97	Wallbox epoint11
99515002	98	Charging station epoint LS 5.0, 22kW
99515003	97	Wall box epoint WB 2.0, 22kW
99515004	97	Wall box epoint WB 2.1, 22kW, flush-mount. b.
99515005	98	Charging point epoint LP 5.0, 22kW
99515101	99	eparkstation software system
EM00000546		Mounting access. connection set WMZ 1"
EM00000646		Mounting access. connection set WMZ 5/4"
EM991114	106	Heating load calculation



Your specialists for surface heating and cooling systems

Expertise, reliability and commitment are **EMPUR®**'s strengths. In addition to the production and sale of high-quality surface heating and cooling systems and components, the company's range of services also includes comprehensive services relating to the planning and installation of our complete systems.

EMPLAN®'s specialist engineers and planning consultants are available to help you with their expertise in demanding property planning in almost all TGA areas such as heating, air conditioning, ventilation, plumbing and electrical.

We have bundled our many years of experience in the installation of surface heating and cooling systems into our **EMSOLUTION®** and support tradesmen to complete their construction projects on time.

EMPUR®, **EMPLAN®** and **EMSOLUTION®** together form the **EMGRUPPE®**. Thus, the three core areas of expertise – production, planning and installation – come from a single source.

TBE . PLANNING . CONCEPTS

EMPLAN®

- Planning surface heating and cooling systems for new builds, modernisation projects and customised solutions
- Project planning for heating, ventilation and air conditioning applications, electrical engineering and swimming pool technology
- Creation of performance specifications
- Planning and designing Geniex projects
- Energy planning and assessment of residential and non-residential buildings (GEG certificates)
- Construction supervision for technical building systems

www.em-plan.net

TBE . PRODUCTION . SALES

EMPUR®

- Plastic heating pipes, insulation and composite panels for surface heating and cooling systems for new builds and modernisation projects
- Manifold and control technology
- Geniex heat distribution systems
- Accessories and tools
- Customised solutions for industrial, sports and commercial buildings

www.empur.com

TBE . ASSEMBLY . SERVICE

EMSOLUTION®

- Installation of surface heating and cooling systems in new build and modernisation projects
- Installation of the CUT-THERM® milling system
- Commissioning of Geniex heat distribution systems and heat pump systems
- Service for technical building installations

www.em-solution.de